

Σ Series SGM□/SGDB USER'S MANUAL

AC Servomotors and Driver

SGMG/SGMS/SGMD/SGM/SGMP Servomotors
SGDB SERVOPACK



正正科技有限公司

購買、維修 此手冊零組件

電話： 037-466333

Email: service@repairtw.com

Line id: @zzzz

www.repairtw.com



YASKAWA

MANUAL NO. TSE-S800-16E

PREFACE

The rapid progress being made in today's automation and information technologies is resulting in a growing need for even more-advanced motion control for future high-tech equipment. The end result is a need for devices that can provide more-precise and quicker motion at higher speeds. Servo control technology makes this possible. Launched by Yaskawa in 1993, the Σ Series consists of innovative AC Servos that were developed using leading-edge servo control technology.

This manual covers all products in the Σ Series, which feature superior functions and performance. This manual was designed to provide comprehensible information for users who are about to use a servo for the first time as well as for users who already have experience in using servos. This manual enables users to understand what Σ -Series AC Servos are all about and how to design, install, operate, and maintain a servo system. Keep this manual in a convenient location and refer to it whenever necessary in operating and maintaining the servo system.

YASKAWA ELECTRIC CORPORATION

上正科技有限公司

購買、維修 此手冊零組件

電話： 037-466333

General Precautions

Email: service@repairtw.com

- Some drawings in this manual are shown with the protective cover or shields removed, in order to describe the detail with more clarity. Make sure all covers and shields are replaced before operating this product.
- Some drawings in this manual are shown as typical example and may differ from the shipped product.
- This manual may be modified when necessary because of improvement of the product, modification or changes in specifications.
Such modification is made as a revision by renewing the manual No.
- To order a copy of this manual, if your copy has been damaged or lost, contact your YASKAWA representative listed on the last page stating the manual No. on the front cover.
- YASKAWA is not responsible for accidents or damages due to any modification of the product made by the user since that will void our guarantee.

NOTES FOR SAFE OPERATION

Read this manual thoroughly before installation, operation, maintenance or inspection of the AC Servo Drives. In this manual, the NOTES FOR SAFE OPERATION are classified as “WARNING” or “CAUTION”.



Indicates a potentially hazardous situation which, if not avoided, could result in death or serious personal injury.



Indicates a potentially hazardous situation which, if not avoided, may result in minor or moderate personal injury and/or damage to the equipment.

In some instances, items described in  may also result in a serious accident. In either case, follow these important items.

上正科技有限公司

購買、維修 此手冊零組件

電話： 037-466333

Email: service@repairtw.com

Line id: @zzzz

www.repairtw.com



WARNING

(WIRING)

- Grounding must be in accordance with the national code and consistent with sound local practices.
Failure to observe this warning may lead to electric shock or fire.

(OPERATION)

- Never touch any rotating motor parts during operation.
Failure to observe this warning may result in personal injury.

(INSPECTION AND MAINTENANCE)

- Be sure to turn OFF power before inspection or maintenance.
Otherwise, electric shock may result.
- Never open the terminal cover while power is ON, and never turn ON power when the terminal cover is open.
Otherwise, electric shock may result.
- After turning OFF power, wait at least five minutes before servicing the product.
Otherwise, residual electric charges may result in electric shock.



CAUTION

(STORAGE AND TRANSPORTATION)

- If disinfectants or insecticides must be used to treat packing materials such as wooden frames, pallets, or plywood, the packing materials must be treated before the product is packaged, and methods other than fumigation must be used.

Example: Heat treatment, where materials are kiln-dried to a core temperature of 56°C for 30 minutes or more.

If the electronic products, which include stand-alone products and products installed in machines, are packed with fumigated wooden materials, the electrical components may be greatly damaged by the gases or fumes resulting from the fumigation process. In particular, disinfectants containing halogen, which includes chlorine, fluorine, bromine, or iodine can contribute to the erosion of the capacitors.



CAUTION

(RECEIVING)

- Use the specified combination of servomotor and SERVOPACK.
Failure to observe this caution may lead to fire or failure.

(INSTALLATION)

- Never use the equipment where it may be exposed to splashes of water, corrosive or flammable gases, or near flammable materials.
Failure to observe this caution may lead to electric shock or fire.

(WIRING)

- Do not connect three-phase power supply to output terminals ① ② and ③.
Failure to observe this caution may lead to personal injury or fire.
- Securely tighten screws on the power supply and motor output terminals.
Failure to observe this caution can result in a fire.

(OPERATION)

- To avoid inadvertent accidents, run the servomotor only in test run (without load).
Failure to observe this caution may result in personal injury.
- Before starting operation with a load connected, set up parameters suitable for the machine.
Starting operation without setting up parameters may lead to overrun failure.
- Before starting operation with a load connected, make sure emergency-stop procedures are in place.
Failure to observe this caution may result in personal injury.
- During operation, do not touch the heat sink.
Failure to observe this caution may result in burns.

(INSPECTION AND MAINTENANCE)

- Do not disassemble the servomotor.
Failure to observe this caution may result in electric shock or personal injury.
- Never change wiring while power is ON.
Failure to observe this caution may result in electric shock or personal injury.

Manual Contents

This manual provides Σ -Series users with information on the following:

- An overview of servo systems for first-time users.
- Checking the product on delivery and basic applications of the servo.
- Servo applications.
- Selecting an appropriate servo for your needs and placing an order.
- Inspection and maintenance.

Manual Structure

All chapters in this manual are classified into one or more of three areas according to their contents: A, B, and C. Refer to the applicable chapters for the information you require.

A: Chapters explaining how to select a servo: For users who wish to gain a basic understanding of Σ Series products or who need to select an appropriate servo.

B: Chapters explaining how to design a servo system: For users who are about to design, install, and operate a Σ -Series Servo Control System.

C: Chapters explaining maintenance: For users who are going to maintain and troubleshoot Σ -Series products.

Chapter	Title	Page	Area
CHAPTER 1	For First-time Users of AC Servos Provides an overview of servos and the Σ Series.	1	A, B
CHAPTER 2	Basic Uses of Σ-series Products Describes steps to take when product is received, plus basic wiring and application methods.	15	B
CHAPTER 3	Applications of Σ-series Products Describes the effective usage of Σ -Series features according to application.	51	B
CHAPTER 4	Using the Digital Operator Describes operating procedures for Σ -Series servos, turning features ON and OFF, setting control constants, etc.	177	B
CHAPTER 5	Servo Selection and Data Sheets Describes selection methods for Σ -Series servos and peripherals and provides servo specifications.	221	A, B
CHAPTER 6	Inspection, Maintenance, and Troubleshooting Describes user maintenance and troubleshooting.	499	C
APPENDIXES			
A	Servo Adjustment	539	B, C
B	List of I/O Signals	555	B, C
C	List of Parameters	561	B, C
D	List of Alarm Displays	569	B, C
INDEX	573	A, B, C

Basic Terms

Unless otherwise specified, the following definitions are used:

Servomotor: Σ -Series SGMG/SGMD/SGMS/SGM/SGMP servomotor

SERVOPACK: An amplifier (Trademark of Yaskawa servo amplifier “ Σ -Series SGDB-□AD SERVOPACK”)

Servodrive: A servomotor and an amplifier (SGDB SERVOPACK)

Servo system: A complete servo control system consisting of servodrive, host controller, and peripheral devices

Visual Aids

The following aids are used to indicate certain types of information for easier reference.



Indicates references for additional information.



Technical terms placed in bold in the text are briefly explained in a “TERMS” section at the bottom of the page. The following kinds of technical terms are explained: Technical terms that need to be explained to users who are not very familiar with servo systems or electronic devices and technical terms specific to Σ Series Servos that need to be explained in descriptions of functions.

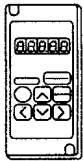

JUSP-OP02A-1

The text indicated by this icon explains the operating procedure using hand-held type digital operator (Type: JUSP-OP02A-1).



The text indicated by this icon explains the operating procedure using mount type digital operator (Type: JUSP-OP03A).

上正科技有限公司

購買、維修 此手冊零組件

電話： 037-466333

Email: service@repairtw.com

Line id: @zzzz

www.repairtw.com

NOTE A Σ -Series Servodrive alone cannot ensure the functionality and performance of the entire machine control system. It must be combined with an appropriate machine and host controller so that the entire control system works properly. Therefore, carefully read the instruction manuals for the machine to be used before attempting to operate the servodrive.

上正科技有限公司
購買、維修 此手冊零組件
電話： 037-466333
Email: service@repairtw.com
Line id: @zzzz
www.repairtw.com

©Yaskawa, 1995

All rights reserved. No part of this publication may be reproduced, stored in a retrieval system, or transmitted, in any form, or by any means, mechanical, electronic, photocopying, recording, or otherwise, without the prior written permission of Yaskawa. No patent liability is assumed with respect to the use of the information contained herein. Moreover, because Yaskawa is constantly striving to improve its high-quality products, the information contained in this manual is subject to change without notice. Every precaution has been taken in the preparation of this manual. Nevertheless, Yaskawa assumes no responsibility for errors or omissions. Neither is any liability assumed for damages resulting from the use of the information contained in this publication.

CONTENTS

CHAPTER 1	FOR FIRST-TIME USERS OF AC SERVOS	1
1.1	Servo Mechanisms	2
1.2	Servo Configuration	5
1.3	Features of Σ -Series Servos	11
1.3.1	Servomotor Type	11
1.3.2	Control Type of SERVOPACKs	11
1.3.3	How to Use the SGDB SERVOPACKs	12
CHAPTER 2	BASIC USES OF Σ-SERIES PRODUCTS	15
2.1	Precautions	16
2.1.1	Notes on Use	16
2.2	Installation	18
2.2.1	Checking on Delivery	18
2.2.2	Servomotors	18
2.2.3	SERVOPACKs	22
2.2.4	Installing the Servomotor	24
2.2.5	Installing the SERVOPACK	27
2.3	Connection and Wiring	30
2.3.1	Connecting to Peripheral Devices	30
2.3.2	Main Circuit Wiring and Power ON Sequence	34
2.3.3	Connection to Host Controller	36
2.4	Conducting a Test Run	40
2.4.1	Test Run in Two Steps	40
2.4.2	Step 1: Conducting a Test Run for Motor without Load	42
2.4.3	Step 2: Conducting a Test Run with the Motor Connected to the Machine	46
2.4.4	Supplementary Information on Test Run	47
2.4.5	Minimum Parameters Required and Input Signals	49
CHAPTER 3	APPLICATIONS OF Σ-SERIES PRODUCTS	51
3.1	Setting Parameters According to Machine Characteristics	54
3.1.1	Changing the Direction of Motor Rotation	54
3.1.2	Setting the Overtravel Limit Function	56
3.1.3	Restricting Torque	59
3.2	Setting Parameters According to Host Controller	64
3.2.1	Inputting Speed Reference	64
3.2.2	Inputting Position Reference	68
3.2.3	Using Encoder Outputs	73
3.2.4	Using Contact I/O Signals	77
3.2.5	Using Electronic Gear	79
3.2.6	Using Contact Input Speed Control	83
3.2.7	Using Torque Control	87
3.2.8	Using Torque Feed-forward Function	94
3.2.9	Using Torque Restriction by Analog Voltage Reference	95
3.2.10	Using the Reference Pulse Inhibit Function (INHIBIT)	97
3.2.11	Using the Reference Pulse Input Filter Selection Function	98
3.2.12	Using the Analog Monitor	99
3.3	Setting Up the Σ SERVOPACK	100

CONTENTS

3.3.1	Setting Parameters	100
3.3.2	Setting the Jog Speed	101
3.3.3	Setting the Number of Encoder Pulses	102
3.3.4	Setting the Motor Type	103
3.3.5	Adjusting the Encoder Supply Voltage	104
3.4	Setting Stop Mode	105
3.4.1	Adjusting Offset	105
3.4.2	Using Dynamic Brake	106
3.4.3	Using Zero-Clamp	107
3.4.4	Using Holding Brake	108
3.5	Running the Motor Smoothly	113
3.5.1	Using the Soft Start Function	113
3.5.2	Using the Smoothing Function	114
3.5.3	Adjusting Gain	114
3.5.4	Adjusting Offset	115
3.5.5	Setting the Torque Reference Filter Time Constant	115
3.6	Minimizing Positioning Time	117
3.6.1	Using Autotuning Function	117
3.6.2	Setting Servo Gain	117
3.6.3	Using Feed-forward Control	119
3.6.4	Using Proportional Control	119
3.6.5	Setting Speed Bias	120
3.6.6	Using Mode Switch	121
3.7	Forming a Protective Sequence	127
3.7.1	Using Servo Alarm Output and Alarm Code Output	127
3.7.2	Using Servo ON Input Signal	130
3.7.3	Using Positioning Complete Signal	131
3.7.4	Using Speed Coincidence Output Signal	134
3.7.5	Using Running Output Signal	136
3.7.6	Using OL Warning and Alarm Output Signals	138
3.7.7	Using Servo Ready Output Signal	140
3.7.8	Handling of Power Loss	141
3.8	Special Wiring	142
3.8.1	Wiring Instructions	142
3.8.2	Wiring for Noise Control	144
3.8.3	Using More Than One Servo Drive	149
3.8.4	Using Regenerative Resistor Units	151
3.8.5	Using an Absolute Encoder	152
3.8.6	Extending an Encoder Cable	162
3.8.7	Using SGDB SERVOPACK with High Voltage Line	164
3.8.8	Connector Terminal Layouts	166
CHAPTER 4	USING THE DIGITAL OPERATOR	177
4.1	Basic Operations	178
4.1.1	Connecting the Digital Operator	178
4.1.2	Digital Operator Functions	179
4.1.3	Resetting Servo Alarms	180

CONTENTS

4.1.4	Basic Functions and Mode Selection	181
4.1.5	Operation in Status Display Mode	182
4.1.6	Operation in Parameter Setting Mode	186
4.1.7	Operation in Monitor Mode	191
4.2	Using the Functions	194
4.2.1	Operation in Alarm Trace-back Mode	194
4.2.2	Operation Using the Digital Operator	197
4.2.3	Autotuning	201
4.2.4	Reference Offset Automatic Adjustment	207
4.2.5	Reference Offset Manual Adjustment Mode	210
4.2.6	Clearing Alarm Trace-back Data	213
4.2.7	Checking Motor Specifications	215
4.2.8	Checking Software Version	216
4.2.9	Current Detection Offset Manual Adjustment Mode	217
CHAPTER 5	SERVO SELECTION ANDDATA SHEETS	221
5.1	Selecting a Σ -Series Servo	223
5.1.1	Selecting a Servomotor	223
5.1.2	Selecting a SERVOPACK	233
5.1.3	Selecting a Digital Operator	235
5.2	SGM Servomotor	237
5.2.1	Ratings and Specifications	237
5.2.2	Mechanical Characteristics	269
5.2.3	Option Specifications	272
5.3	SERVOPACK Ratings and Specifications	282
5.3.1	Combined Specifications	282
5.3.2	Ratings and Specifications	285
5.3.3	Overload Characteristics	288
5.3.4	Starting Time and Stopping Time	289
5.3.5	Load Inertia	290
5.3.6	Overhanging Loads	291
5.4	Σ -Series Dimensional Drawings	292
5.4.1	Servomotor Dimensional Drawings	292
5.4.2	SERVOPACK Dimensional Drawings	400
5.4.3	Digital Operator Dimensional Drawings	412
5.5	Selecting Peripheral Devices	414
5.5.1	Selecting Peripheral Devices	414
5.5.2	Order List	424
5.6	Specifications and Dimensional Drawings of Peripheral Devices	442
5.6.1	Cable Specifications and Peripheral Devices	442
5.6.2	Motor Cables	446
5.6.3	Connector	447
5.6.4	Brake Power Supply	466
5.6.5	Encoder Cables	469
5.6.6	Battery for Absolute Encoder	480
5.6.7	1CN Connector	481
5.6.8	Connector Terminal Block Converter Unit	483

CONTENTS

5.6.9	Cable With 1CN Connector and One End Without Connector	485
5.6.10	Circuit Breaker	486
5.6.11	Noise Filter	486
5.6.12	Magnetic Contactor	488
5.6.13	Surge Suppressor	490
5.6.14	Regenerative Resistor Unit	490
5.6.15	Variable Resistor for Speed Setting	491
5.6.16	Encoder Signal Converter Unit	492
5.6.17	Cables for Connecting PC and SERVOPACK	494
CHAPTER 6 INSPECTION, MAINTENANCE, AND TROUBLESHOOTING . 499		
6.1	Inspection and Maintenance	500
6.1.1	Servomotor	500
6.1.2	SERVOPACK	501
6.1.3	Replacing Battery for Absolute Encoder	502
6.2	Troubleshooting	503
6.2.1	Troubleshooting Problems with Alarm Display	503
6.2.2	Troubleshooting Problems With No Alarm Display	529
6.2.3	Internal Connection Diagram and Instrument Connection Examples	531
A	Servo Adjustment	539
A.1	Σ -Series AC SERVOPACK Gain Adjustment	540
A.1.1	Σ -Series AC SERVOPACKs and Gain Adjustment Methods	540
A.1.2	Basic Rules for Gain Adjustment	541
A.2	Adjusting a Speed-control SERVOPACK	542
A.2.1	Adjusting Using Auto-tuning	542
A.2.2	Manual Adjustment	543
A.3	Adjusting a Position-control SERVOPACK	546
A.3.1	Adjusting Using Auto-tuning	546
A.3.2	Manual Adjustment	547
A.4	Gain Setting References	551
A.4.1	Guidelines for Gain Settings According to Load Inertia Ratio	551
B	List of I/O Signals	555
C	List of Parameters	561
D	List of Alarm Displays	569
INDEX		573

FOR FIRST-TIME USERS OF AC SERVOS

1

1

This chapter is intended for first-time users of AC servos. It describes the basic configuration of a servo mechanism and basic technical terms relating to servos.

Users who already have experience in using a servo should also take a look at this chapter to understand the features of Σ -Series AC Servos.

1.1 Servo Mechanisms	2
1.2 Servo Configuration	5
1.3 Features of Σ-Series Servos	11
1.3.1 Servomotor Type	11
1.3.2 Control Type of SERVOPACKs	11
1.3.3 How to Use the SGDB SERVOPACKs	12

Line id: @zzzz

www.repairtw.com

1.1 Servo Mechanisms

You may be familiar with the following terms:

- Servo
- **Servo mechanism**
- Servo control system

In fact, these terms are synonymous. They have the following meaning:

A control mechanism that monitors physical quantities such as specified positions.

In short, a servo mechanism is like a servant who does tasks faithfully and quickly according to his master's instructions. In fact, "servo" originally derives from the word "servant."

上正科技有限公司

購買、維修 此手冊零組件

電話： 037-466333

Email: service@repairtw.com

Line id: @zzzz

www.repairtw.com



Servo mechanism

According to Japanese Industrial Standard (JIS) terminology, a "servo mechanism" is defined as a mechanism that uses the position, direction, or orientation of an object as a process variable to control a system to follow any changes in a target value (set point). More simply, a servo mechanism is a control mechanism that monitors physical quantities such as specified positions. Feedback control is normally performed by a servo mechanism. (Source: JIS B0181)

Servo system could be defined in more detail as a mechanism that:

- Moves at a specified speed and
- Locates an object in a specified position

To develop such a servo system, an automatic control system involving **feedback control** must be designed. This automatic control system can be illustrated in the following block diagram:

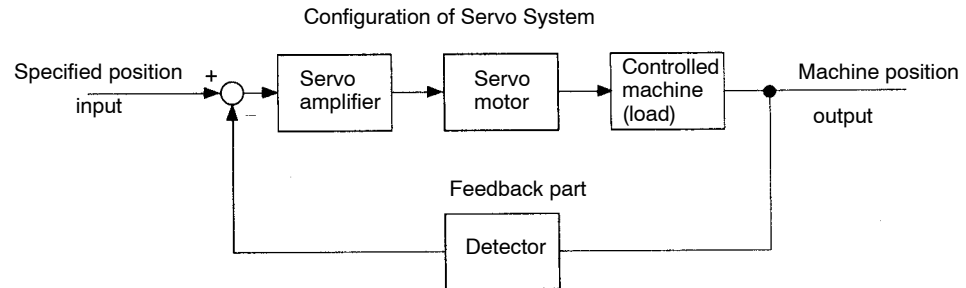

This servo system is an automatic control system that detects the machine position (output data), feeds back the data to the input side, compares it with the specified position (input data), and moves the machine by the difference between the compared data.

In other words, the servo system is a system to control the output data to match the specified input data.

If, for example, the specified position changes, the servo system will reflect the changes.

In the above example, input data is defined as a position, but input data can be any physical quantities such as orientation (angle), water pressure, or voltage.

Position, speed, force (torque), electric current, and so on are typical controlled values for a servo system.

The main technical terms used in this manual are as follows:

- 1) Servo mechanism
- 2) Servo

Normally, servo is synonymous with servo mechanism. However, because “mechanism” is omitted, the meaning becomes somewhat ambiguous. Servo may refer to the entire servo mechanism but may also refer to an integral part of a servo mechanism such as a servomotor or a servo amplifier. This manual also follows this convention in the use of the term “servo”.



Feedback control

A control that returns process variables to the input side and forms a closed loop. It is also called closed-loop control.

3) Servo control system

Servo control system is almost synonymous with servo mechanism but places the focus on system control. In this manual, the term “servo system” is also used as a synonym of servo control system.

Related Terms	Meaning
Servomotor	General servomotors or Yaskawa SGM□ servomotors. In some cases, a position detector (encoder) is included in a servomotor.
SERVOPACK	Trademark of Yaskawa servo amplifier “SGDB SERVOPACK.”
Servo drive	A servomotor and amplifier pair. Also called “servo.”
Servo system	A closed control system consisting of a host controller, servo drive and controlled system to form a servo mechanism.

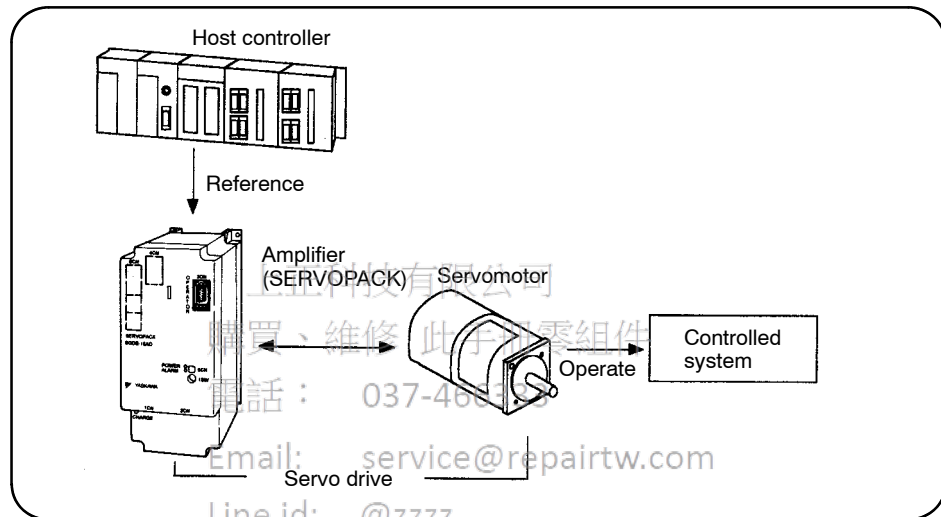

www.repairtw.com

1.2 Servo Configuration

The following diagram illustrates a servo system in detail:

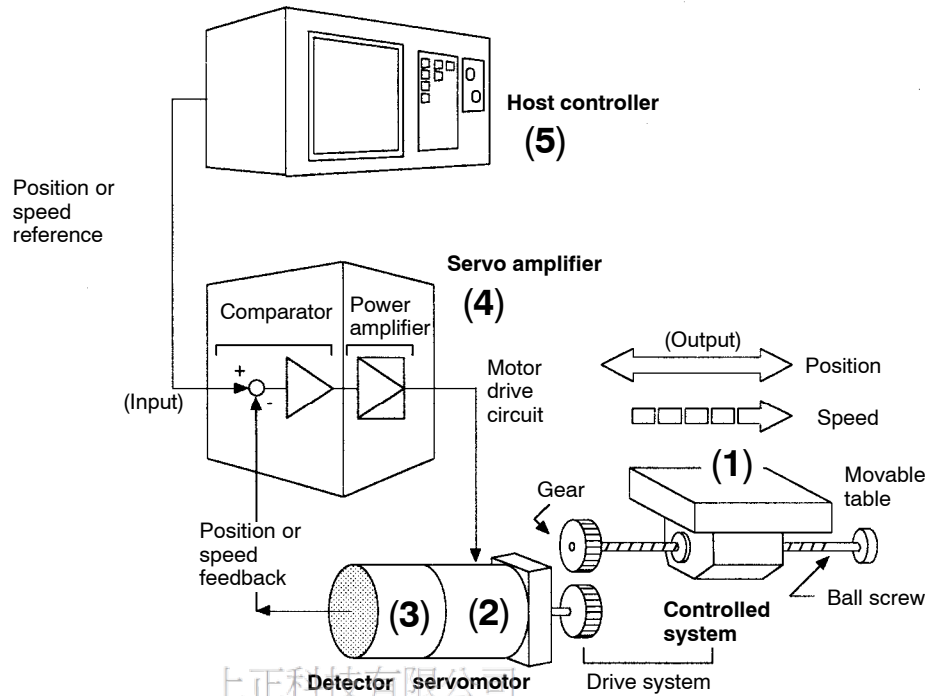

- 上正科技有限公司
購買、維修 此手冊零組件
電話： 037-466333
Email: service@repairtw.com
Line id: @repairtw
www.repairtw.com
- (1) **Controlled system:** Mechanical system for which the position or speed is to be controlled. This includes a drive system that transmits torque from a servomotor.
 - (2) **Servomotor:** A main actuator that moves a controlled system. Two types are available: AC servomotor and DC servomotor.
 - (3) **Detector:** A position or speed detector. Normally, an encoder mounted on a motor is used as a position detector.
 - (4) **Servo amplifier:** An amplifier that processes an error signal to correct the difference between a reference and feedback data and operates the servomotor accordingly. A servo amplifier consists of a comparator, which processes error signals, and a power amplifier, which operates the servomotor.
 - (5) **Host controller:** A device that controls a servo amplifier by specifying a position or speed as a set point.

Servo components (1) to (5) are outlined below:

(1) Controlled system

In the previous figure, the controlled system is a movable table for which the position or speed is controlled. The movable table is driven by a ball screw and is connected to the servomotor via gears.

So, the **drive system** consists of:

Gears + Ball Screw

This drive system is most commonly used because the power transmission ratio (gear ratio) can be freely set to ensure high positioning accuracy. However, play in the gears must be minimized.

The following drive system is also possible when the controlled system is a movable table:

Coupling + Ball Screw

When the power transmission ratio is 1 : 1, a coupling is useful because it has no play.

This drive system is widely used for machining tools.

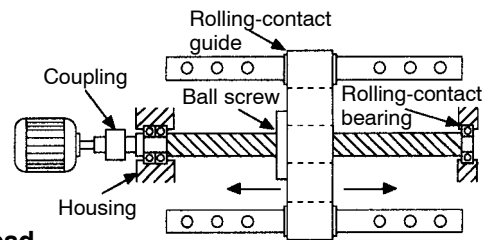

Timing Belt + Trapezoidal Screw Thread

A timing belt is a coupling device that allows the power transmission ratio to be set freely and that has no play.

A trapezoidal screw thread does not provide excellent positioning accuracy, so can be treated as a minor coupling device.

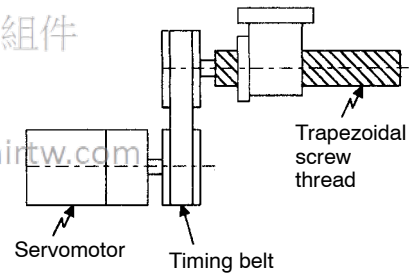

To develop an excellent servo system, it is important to select a rigid drive system that has no play.

Configure the controlled system by using an appropriate drive system for the control purpose.



Drive system

Also called a drive mechanism.

A drive system connects an actuator (such as a servomotor) to a controlled system and serves as a mechanical control component that transmits torque to the controlled system, orientates the controlled system, and converts motion from rotation to linear motion and vice versa.

(2) Servomotor

(a) DC servomotor and AC servomotor

Servomotors are divided into two types: DC servomotors and AC servomotors.

DC servomotors are driven by direct current (DC). They have a long history. Up until the 1980s, the term “servomotor” used to imply a DC servomotor.

From 1984, AC servomotors were emerging as a result of rapid progress in micro-processor technology. Driven by alternating current (AC), AC servomotors are now widely used because of the following advantages:

- Easy maintenance: No brush
- High speed: No limitation in rectification rate

Note however that servomotors and SERVOPACKs use some parts that are subject to mechanical wear or aging. For preventive maintenance, inspect and replace parts at regular intervals.

For details, refer to *Chapter 6 Inspection, Maintenance, and Troubleshooting*.

(b) AC servomotor

AC servomotors are divided into two types: synchronous type and induction type. The synchronous type is more commonly used.

For a synchronous type servomotor, motor speed is controlled by changing the frequency of alternating current.

A synchronous type servomotor provides strong holding torque when stopped, so this type is ideal when precise positioning is required. Use this type for a servo mechanism for position control.

The following figure illustrates the structure of a synchronous type servomotor:

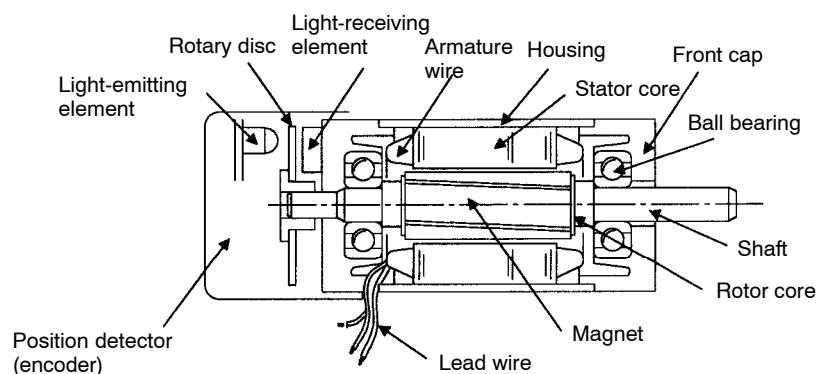

Yaskawa SGM□ servomotors are of the synchronous type.

(c) Performance of servomotor

A servomotor must have “instantaneous power” so that it can start as soon as a start reference is received.

The term “power rating (kW/s)” is used to represent instantaneous power.

It refers to the electric power (kW) that a servomotor generates per second.

The greater the power rating, the more powerful the servomotor.

(3) Detector

A servo system requires a position or speed detector. It uses an encoder mounted on a servomotor for this purpose.

Encoders are divided into the following two types:

(a) Incremental Encoder

An incremental encoder is a pulse generator, which generates a certain number of pulses per revolution (e.g., 2,000 pulses per revolution). If this encoder is connected to the mechanical system and one pulse is defined as a certain length (e.g., 0.001 mm), it can be used as a position detector.

However, this encoder does not detect an absolute position and merely outputs a pulse train. Zero point return operation must be performed before positioning.

The following figure illustrates the operation principle of a pulse generator:

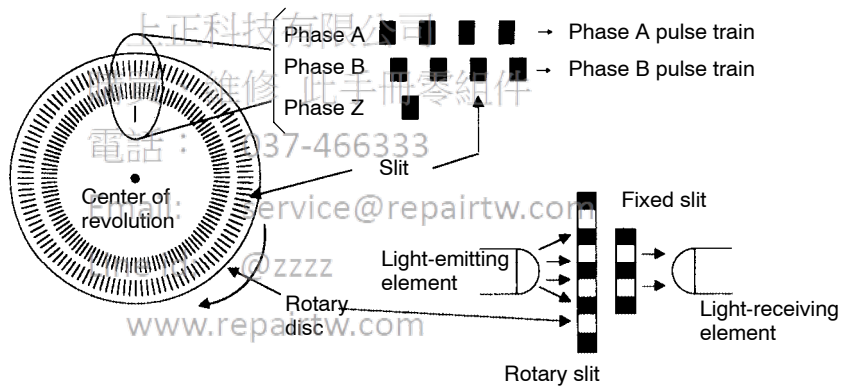

(b) Absolute encoder

An absolute encoder is designed to detect an absolute angle of rotation as well as to perform the general functions of an incremental encoder. With an absolute encoder, therefore, it is possible to create a system that does not require zero point return operation at the beginning of each operation.

- Difference between an absolute and incremental encoder:
An absolute encoder will keep track of the motor shaft position even if system power is lost and some motion occurs during that period of time. The incremental encoder is incapable of the above.

(4) Servo amplifier

A servo amplifier is required to operate an AC servomotor.

The following figure illustrates the configuration of a servo amplifier:

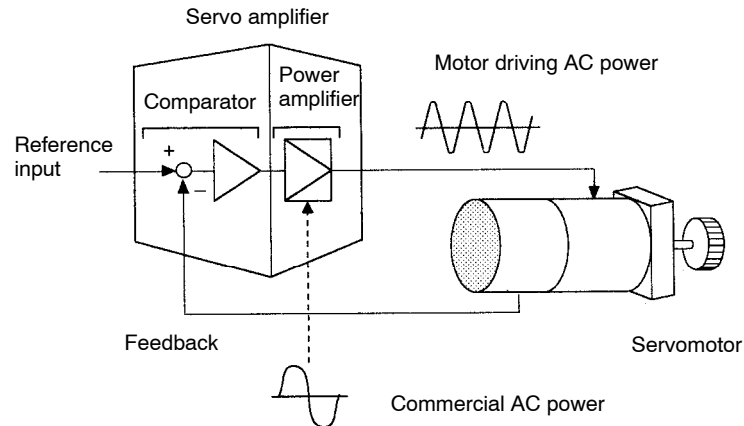

A servo amplifier consists of the following two sections:

(a) Comparator

A comparator consists of a comparison function and a control function. The comparison function compares reference input (position or speed) with a feedback signal and generates a differential signal.

The control function amplifies and transforms the differential signal. In other words, it performs proportional (P) control or **proportional/integral (PI) control**. (It is not important if you do not understand these control terms completely at this point.)

(b) Power amplifier

A power amplifier runs the servomotor at a speed or torque proportional to the output of the comparator. In other words, from the commercial power supply of 50/60 Hz, it generates alternating current with a frequency proportional to the reference speed and runs the servomotor with this current.



Proportional/integral (PI) control

PI control provides more accurate position or speed control than proportional control, which is more commonly used.

(5) Host controller

A host controller controls a servo amplifier by specifying a position or speed as a set point.

For speed reference, a position control loop may be formed in the host controller when a position feedback signal is received. Yaskawa **MP920** is a typical host controller.

上正科技有限公司

購買、維修 此手冊零組件

電話： 037-466333

Email: service@repairtw.com

Line id: @zzzz

www.repairtw.com



MP920

A machine controller. If combined with a servo amplifier for speed control (maximum 44 axes control), the MP920 can provide position control. The MP920 also provides programmable controller functions.

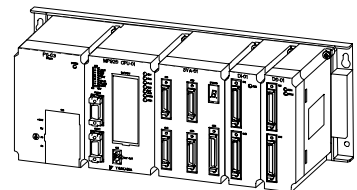

1.3 Features of Σ -Series Servos

This section describes the features of Σ -Series servos.

1.3.1 Servomotor Type

Σ -Series SGM□ servomotors are synchronous type servomotors and have the following features:

	Rated rotation speed Maximum rotation speed	Rated output
SGMG	1500 r/min 3000 r/min	0.45 to 15 kW (10 models)
	1000 r/min 2000 r/min	0.3 to 6.0 kW (8 models)
SGMS	3000 r/min 4500 r/min	1.0 to 5.0 kW (6 models)
SGMD	2000 r/min 3000 r/min	2.2 to 4.0 kW (3 models)
SGM	3000 r/min 4500 r/min	0.4 to 0.8 kW (2 models)
SGMP	3000 r/min 4500 r/min	0.4 to 1.5 kW (3 models)

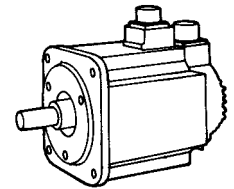

SGMG type

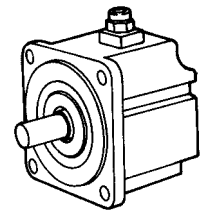

SGMP type

1.3.2 Control Type of SERVOPACKS

SGDB model SERVOPACKs allow the control of speed, position and torque.

- Speed control (analog reference)

Accepts an analog voltage speed reference.

- Speed control (contact reference)

There are 3 internally set speeds. One of these is selected as a reference by a contact.

- Position control (pulse reference)

Accepts a pulse train position reference

- Torque control (analog reference)

Accepts an analog voltage torque reference

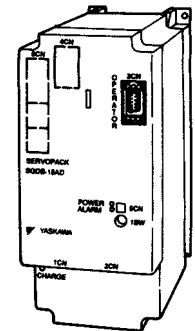

SGDB SERVOPACK

1.3.3 How to Use the SGDB SERVOPACKs

■ Using SERVOPACK for Speed Control

The most common use of a SERVOPACK for speed control is shown below:

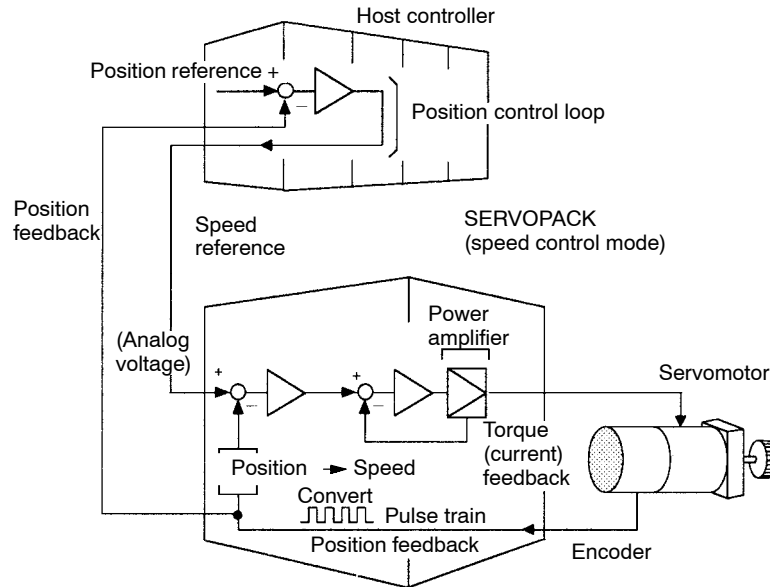

As shown in the above figure, a position control loop is formed in the host controller. The host controller compares a position reference with a position feedback signal and sends the processed result to the SERVOPACK as a speed reference.

In this way the host controller can be freed from performing the servo mechanism control. The SERVOPACK undertakes the speed control loop and subsequent control processing.

The Yaskawa programmable machine controller MP920 is used as a typical host controller.

上海亞細亞有限公司
 電話：037-466333
 Line id: @zzzz

1

■ Using SERVOPACK for Torque Control

SERVOPACK for torque control can be used as shown below:

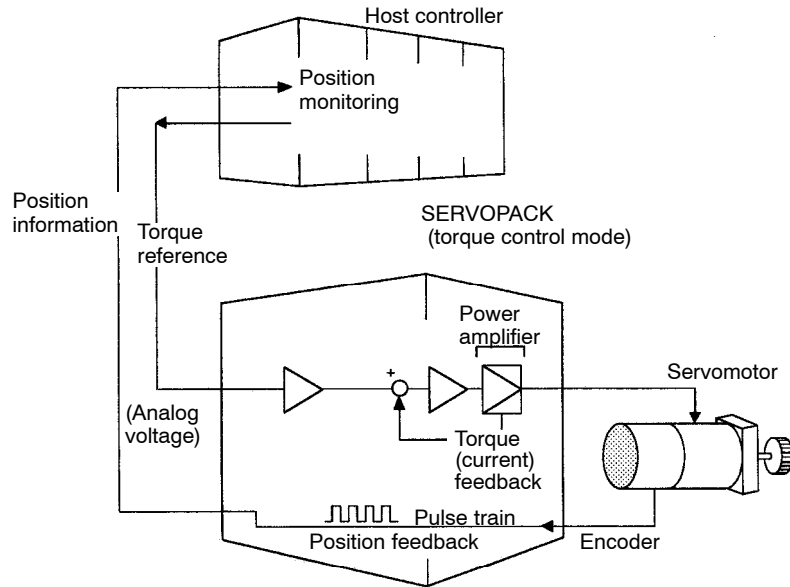

The host controller outputs a torque reference to control the SERVOPACK. It also receives a pulse train (position information) from the SERVOPACK and uses it to monitor the position.

上正科技有限公司

■ Using SERVOPACK for Position Control

SERVOPACK for position control can be used as shown below:

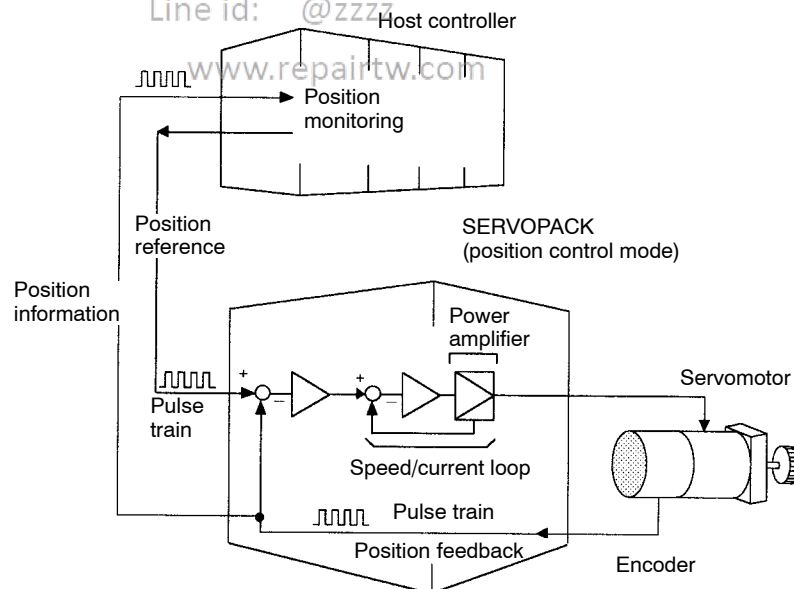

購買、維修 此手冊零組件
 電話： 037-466333
 Email: service@repairtw.com
 Line id: @zzzz

The host controller can send a position reference (pulse train) to the SERVOPACK to perform positioning or interpolation.
This type of SERVOPACK contains a position control loop.

Parameters can be used to select either of the following pulse trains:

- (1) Code and pulse train
- (2) Two-phase pulse train with 90° phase difference
- (3) Forward and reverse pulse trains

The host controller receives a pulse train (position information) from the SERVOPACK and uses it to monitor the position.

■ Setting Parameters

A Digital Operator can be used to set parameters for a SERVOPACK as follows:

- Setting parameters to enable or disable each function
- Setting parameters required for functions to be used

Set parameters according to the servo system to be set up.

購買、維修 此手冊零組件

電話： 037-466333

Email: service@repairtw.com

Line id: @zzzz

www.repairtw.com

BASIC USES OF Σ -SERIES PRODUCTS

2

This chapter describes the first things to do when Σ -Series products are delivered. It also explains the most fundamental ways of connecting and operating Σ -Series products. Both first-time and experienced servo users **must read** this chapter.

2.1	Precautions	16
2.1.1	Notes on Use	16
2.2	Installation	18
2.2.1	Checking on Delivery	18
2.2.2	Servomotors	18
2.2.3	SERVOPACKs	22
2.2.4	Installing the Servomotor	24
2.2.5	Installing the SERVOPACK	27
2.3	Connection and Wiring	30
2.3.1	Connecting to Peripheral Devices	30
2.3.2	Main Circuit Wiring and Power ON Sequence	34
2.3.3	Connection to Host Controller	36
2.4	Conducting a Test Run	40
2.4.1	Test Run in Two Steps	40
2.4.2	Step 1: Conducting a Test Run for Motor without Load	42
2.4.3	Step 2: Conducting a Test Run with the Motor Connected to the Machine	46
2.4.4	Supplementary Information on Test Run	47
2.4.5	Minimum Parameters Required and Input Signals	49

2.1 Precautions

This section provides notes on using Σ-Series products.

2.1.1 Notes on Use

NOTE Always note the following to ensure safe use.

Use 200VAC power supply

Be sure to use the correct type. Do not plug the servomotor directly into the power frequency supply (Direct connection to the power frequency supply will damage the servomotor.)

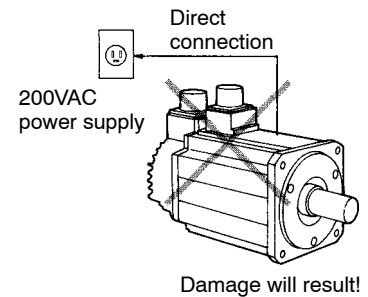

Always use the SGM□ servomotor and SGDB SERVOPACK in pairs.

Check whether the combination of applicable motor series of SERVOPACK and of SGM□ (motor series) is correct or not. Check the setting of parameter Cn-2A (motor selection) and always after changing its combination. The motor may get damaged if the combination is not correct.

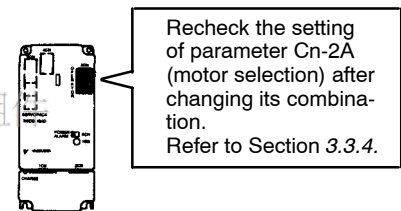

Email: service@repairtw.com

Line id: @zzzz

Do not change wiring when power is ON.

Always turn the power OFF before connecting or disconnecting a connector.
(Except for Digital Operator (Types: JUSP-OP02A-1, JUSP-OP03A))

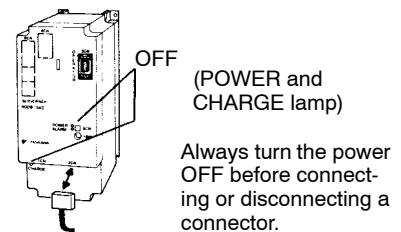

Note that residual voltage still remains in the SERVOPACK even after the power is turned OFF.

Even after the power is turned OFF, residual electric charge still remains in the capacitor inside the SERVOPACK. To prevent an electric shock, always wait for the CHARGE lamp to go OFF before starting inspection (if necessary).

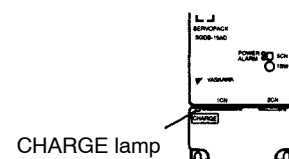

Always follow the specified installation method.

The SERVOPACK generates heat. Install the SERVOPACK so that it can radiate heat freely. Note also that the SERVOPACK must be in an environment free from condensation, vibration and shock.

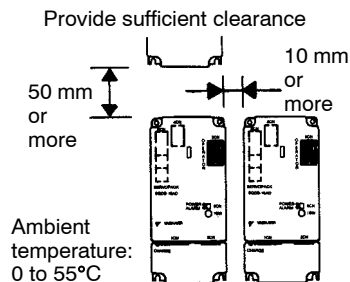

Perform noise reduction and grounding properly.

If the signal line is noisy, vibration or malfunction will result.

- Separate high-voltage cables from low-voltage cables.
- Use cables as short as possible.
- Ground the SERVOPACK ground terminal with the resistance 100Ω or less for the servomotor and SERVOPACK.
- Never use a line filter for the power supply in the motor circuit.

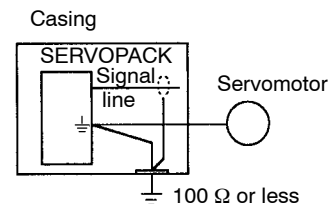

2

Conduct a voltage resistance test under the following conditions.

- Voltage: 1500 Vrms AC, one minute
- Current limit: 100 mA
- Frequency: 50/60 Hz
- Voltage application points: Between r, t, R, S, T terminals and frame ground (connect terminals securely).



Conduct a voltage resistance test under the conditions given on the left.

Use a fast-response type ground-fault interrupter.

For a ground-fault interrupter, always use a fast-response type or one designed for PWM inverters. Do not use a time-delay type.

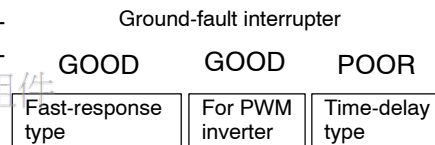

Do not perform continuous operation under overhanging load.

Continuous operation cannot be performed by rotating the motor from the load and applying regenerative braking. Regenerative braking by the SERVOPACK can be applied only for a short period, such as the motor deceleration time.

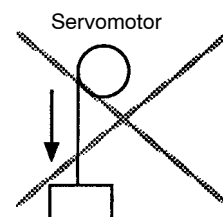

Do not apply regenerative braking continuously.

The servomotor cannot be operated by turning the power ON and OFF.

Frequently turning the power ON and OFF causes the internal circuit elements to deteriorate. Always start or stop the servomotor by using reference pulses.

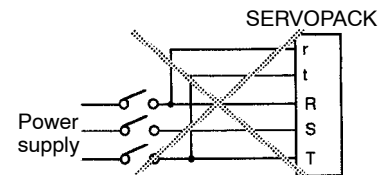

Do not start or stop by turning power ON and OFF.

2.2 Installation

This section describes how to check Σ-Series products on delivery and how to install them.

2.2.1 Checking on Delivery

When Σ-Series products are delivered, check the following items:

Check Items	Remarks
Check if the delivered products are the ones you ordered.	Check the types marked on the nameplates of servomotor and SERVOPACK (see the table below).
Check if the motor shaft rotates smoothly.	If the motor shaft is smoothly turned by hand, it is normal. However, if the motor has brakes, it cannot be turned manually.
Check for damage.	Check the overall appearance, and check for damage or scratches resulting from transportation.
Check screws for looseness.	Check for looseness by using a screwdriver as necessary.

If any of the above items are faulty or incorrect, contact the dealer from which you purchased the products or your nearest local sales representative.

上正科技有限公司

購買、維修 此手冊零組件

電話： 037-466333

2.2.2 Servomotors

External Appearance and Nameplate Examples

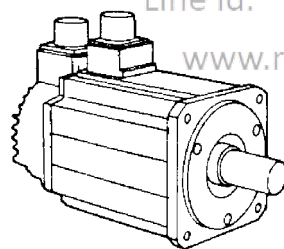

Σ-II Series Servomotor

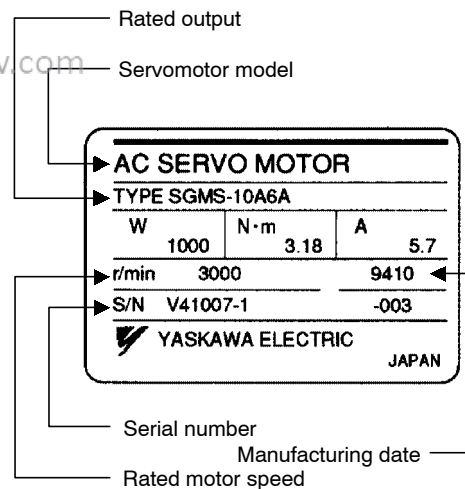

■ Model Numbers

Standard Servomotors

SGM S – 10 A 6 A □ □

Σ Series servomotor

Series name of products

- G: SGMS
- S: SGMS
- D: SGMD

Motor capacity
(See the following table.)

Standard
A: YASKAWA Standard

Encoder specifications
(See the following table.)

Option specifications

- B: 90 VDC Brake
- C: 24 VDC Brake
- S: Oil seal
- F: 90 VDC Brake Oil seal
- G: 24 VDC Brake Oil seal

Shaft Specifications

- A: Standard (straight without key, with option specification)
- B: Straight with key, shaft end tap (one place)
- C: Taper 1/10, with parallel key
- D: Taper 1/10, with semicircle key (For G series 05, 09 type only)

Rated rotation speed

- A: SGMG 1500 min⁻¹
- SGMS 3000 min⁻¹
- SGMD 2000 min⁻¹
- B: SGMG 1000 min⁻¹

Servomotor Capacity (kW)

Symbol	SGMG		SGMS	SGMD	Symbol	SGMG		SGMS	SGMD
	1500 min ⁻¹	1000 min ⁻¹	3000 min ⁻¹	2000 min ⁻¹		1500 min ⁻¹	1000 min ⁻¹	3000 min ⁻¹	2000 min ⁻¹
03	–	0.3	–	–	30	2.9	3.0	3.0	–
05	0.45	–	–	–	32	–	–	–	3.2
06	–	0.6	–	–	40	–	–	4.0	4.0
09	0.85	0.9	–	–	44	4.4	4.4	–	–
10	–	–	1.0	–	50	–	–	5.0	–
12	–	1.2	–	–	55	–	–	–	–
13	1.3	–	–	–	60	–	6.0	–	–
15	–	–	1.5	–	75	7.5	–	–	–
20	1.8	2.0	2.0	–	1A	11	–	–	–
22	–	–	–	2.2	1E	15	–	–	–

Encoder Specifications

Code	Specification	SGMG	SGMS	SGMD
2	8192 P/R incremental	Optional	Standard	Optional
6	4096 P/R incremental	Standard	Optional	Optional
W	12-bit absolute	Optional	Optional	Standard
S	15-bit absolute	Optional	Optional	Optional

NOTE Refer to Section 5.1.1 *Selecting a Servomotor* for the SGMP-15A type.

Servomotors with Gears

SGM G – 05 A 2 A S A R □

Σ-Series servomotor

Series name

- G: SGMG
- S: SGMS

Motor capacity
(See the following table.)

Standard

- A: YASKAWA Standard

Encoder specifications
(See the following table.)

Rated rotation speed

- A: SGMG 1500 min⁻¹
- SGMS 3000 min⁻¹
- B: SGMG 1000 min⁻¹

Brake specifications

- Blank: Without brake
- B: With 90 VDC brake
- C: With 24 VDC brake

Shaft specifications
(See the following table.)

Gear ratio
(See the following table.)

Gear type (See the following table.)

2

Motor Capacity (kW)

Symbol	SGMG		SGMS	Symbol	SGMG		SGMS
	1500 min ⁻¹	1000 min ⁻¹	3000 min ⁻¹		1500 min ⁻¹	1000 min ⁻¹	3000 min ⁻¹
03	–	0.3	–	30	2.9	3.0	3.0
05	0.45	–	–	40	–	–	4.0
06	–	0.6	–	44	4.4	4.4	–
09	0.85	0.9	–	50	–	–	5.0
10	–	–	1.0	55	5.5	–	–
12	–	1.2	–	60	–	6.0	–
13	1.3	–	–	75	7.5	–	–
15	–	–	1.5	1A	11	–	–
20	1.8	2.0	2.0	–	–	–	–

Encoder Specifications Email: service@repairtw.com

Code	Specification	SGMG	SGMS
2	8192 P/R incremental	Optional	Standard
6	4096 P/R incremental	Standard	Optional
W	12-bit absolute	Optional	Optional
S	15-bit absolute	Optional	Optional

Gear Type

Code	Specification	SGMG	SGMS
S	With foot	Standard	
T	Flange	Standard	
L	IMT planetary low-backlash gear	Standard	Standard

Gear Ratio (Varies with Gear Type.)

Code	Specification	SGMG	SGMS
A	1/6	S, T*	
B	1/11	S, T	
C	1/21	S, T	
1	1/5	L	L
2	1/9	L	L
5	1/20	L*	L
7	1/29 or 1/33	L, S, T*	L*
8	1/45	L*	L*

* Not all applicable models available.

Shaft Specifications (Varies with Gear Type.)

Code	Specification	SGMG	SGMS
K	Straight, with key	L	L
R	Straight, with key and tap	S, T	

2

上正科技有限公司

購買、維修 此手冊零組件

電話： 037-466333

Email: service@repairtw.com

Line id: @zzzz

www.repairtw.com

2.2.3 SERVOPACKs

External Appearance and Nameplate Examples

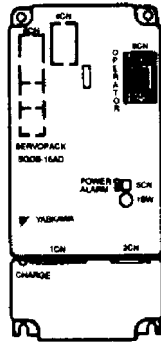

Σ -Series SGDB
SERVOPACK

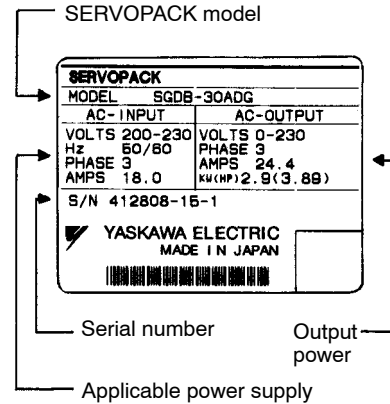

2

Model Numbers

SGDB - 10 A D S - □

Σ -Series
SGDB SERVOPACK

Motor capacity
(See the following table.)

Voltage
A: 200 V

Model
D: torque, speed, position control

Applicable motor series

- G: SGMG (1500 min⁻¹)
- M: SGMG (1000 min⁻¹)
- S: SGMG
- D: SGMG
- P: SGMP
- Blank: SGM

Option specifications

- P: Duct ventilation type

上正科技有限公司

購買、維修 此手冊零組件

電話： 037-466333

Email: service@repairtw.com

line id: @zzzz

www.repairtw.com

Motor Capacity (kW)

Maximum Applicable Servomotor Capacity Symbol	Capacity	Maximum Applicable Servomotor Capacity Symbol	Capacity
03	0.3	44	4.4
05	0.50	50	5.0
07	0.7	60	6.0
10	1.0	75	7.5
15	1.5	1A	11
20	2.0	1E	15
30	3.0	-	-

上正科技有限公司

購買、維修 此手冊零組件

電話： 037-466333

Email: service@repairtw.com

Line id: @zzzz

www.repairtw.com

2.2.4 Installing the Servomotor

Servomotor SGM□ type can be installed either horizontally or vertically. However, if the servomotor is installed incorrectly or in an inappropriate location, the service life will be shortened or unexpected problems will occur. To prevent this, always observe the installation instructions described below.

When using the models with an oil seal, installing the motor with the output shaft up may cause oil to enter the motor depending on the operating conditions. Check the operating conditions.

Before installation:

Anticorrosive paint is coated on the edge of the motor shaft to prevent it from rusting during storage. Clean off the anticorrosive paint thoroughly using a cloth before installing the motor.

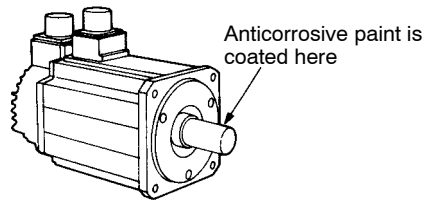

NOTE Avoid getting thinner on other parts of the servomotor when cleaning the shaft.

Storage:

When the servomotor is to be stored with the power cable disconnected, store it in the following temperature range:

Between -20°C and 60°C

Installation sites:

The servomotor SGM□ type is designed for indoor use.

Install servomotor in an environment which meets the following conditions:

- a) Free from corrosive and explosive gases
- b) Well-ventilated and free from dust and moisture
- c) Ambient temperature of 0 to 40°C
- d) Relative humidity of 20% to 80% (non-condensing)
- e) Inspection and cleaning can be performed easily

If the servomotor is used in a location subject to water or oil mist, the motor can be protected by taking necessary precautions on the motor side. However, if the shaft opening is to be sealed, specify the motor with oil seal. Install with the electrical connector facing downward.

Alignment:

Align the shaft of the servomotor with that of the equipment to be controlled, then connect the shafts with couplings. Install the servomotor so that alignment accuracy falls within the range shown below.

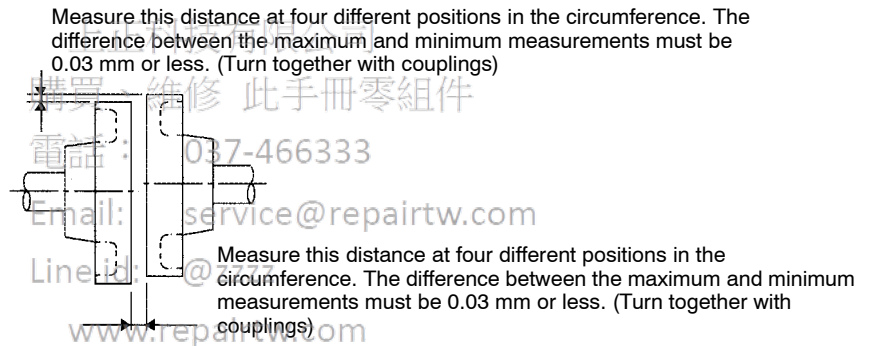

NOTE If the shafts are not aligned properly, vibration will occur, resulting in damage to the bearings. When using a pinion gear mounted directly to the motor output shaft, contact your YASKAWA representative.

**Shaft opening**

Refers to the space where the shaft comes out from the motor.

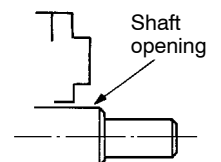

BASIC USES OF Σ-SERIES PRODUCTS

2.2.4 Installing the Servomotor cont.

A precision detector (encoder) is mounted on the opposite-drive end of the servomotor. To mount a coupling, always protect the shaft from impacts that could damage the detector.

Perform a mechanical design so that **thrust load and radial load** applied to the servomotor shaft end falls within the range given in the following table.

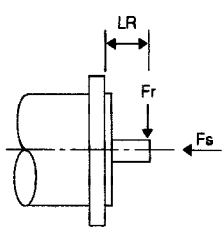
Motor Type	Allowable Radial Load Fr [N(lb)]	Allowable Thrust Load Fs [N(lb)]	LR [mm(in.)]	Reference Drawing
SGMG-05A□A	490 (110)	98 (22)	58 (2.28)	
-09A□A	490 (110)	98 (22)		
-13A□A	686 (154)	343 (77)		
-20A□A	1176 (265)	490 (110)	79 (3.11)	
-30A□A	1470 (331)	490 (110)		
-44A□A	1470 (331)	490 (110)		
-55A□A	1764 (397)	588 (132)	113 (4.45)	
-75A□A	1764 (397)	588 (132)		
-1AA□A	1764 (397)	588 (132)	116 (4.57)	
-1EA□A	4998 (1125)	2156 (485)	116 (4.57)	
SGMG-03A□B	490 (110)	98 (22)	58 (2.28)	
-06A□B	490 (110)	98 (22)		
-09A□B	686 (154)	343 (77)		
-12A□B	1176 (265)	490 (110)	79 (3.11)	
-20A□B	1470 (331)	490 (110)		
-30A□B	1470 (331)	490 (110)		
-44A□B	1764 (397)	588 (132)	113 (4.45)	
-60A□B	1764 (397)	588 (132)		
SGMS-10A	686 (154)	196 (44)	45 (1.77)	
-15A	686 (154)	196 (44)		
-20A	686 (154)	196 (44)		
-30A	980 (221)	392 (88)	63 (2.48)	
-40A	1176 (265)	392 (88)		
-50A	1176 (265)	392 (88)		
SGMD-22A	1176 (265)	490 (110)	55 (2.17)	
-32A	1176 (265)	490 (110)		
-40A	1176 (265)	490 (110)	65 (2.56)	
SGMP-15A	490 (110)	147 (33)	35 (1.38)	

Note Allowable radial loads shown above are the maximum values that could be applied to the shaft end.



Thrust load and radial load

1. Thrust load: Shaft-end load applied parallel to the centerline of a shaft
2. Radial load: Shaft-end load applied perpendicular to the centerline of a shaft

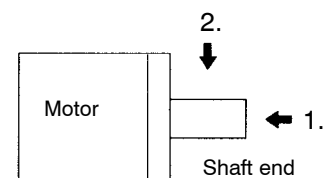

2.2.5 Installing the SERVOPACK

Σ-Series SGDB SERVOPACK is a base-mount type servo controller.

Incorrect installation will cause problems. Always observe the installation instructions described below.

Storage:

When the SERVOPACK is to be stored with the power cable disconnected, store it in the following temperature range:

Between -20°C and 85°C

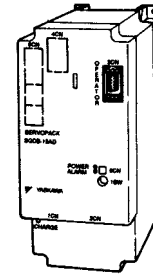

SGDB SERVOPACK

2

Installation sites:

Situation	Notes on Installation
When installed in a control panel	Design the control panel size, unit layout, and cooling method so that the temperature around the periphery of the SERVOPACK does not exceed 55°C .
When installed near a heating unit	Suppress radiation heat from the heating unit and a temperature rise caused by convection so that the temperature around the periphery of the SERVOPACK does not exceed 55°C .
When installed near a source of vibration	Install a vibration isolator underneath the SERVOPACK to prevent it from receiving vibration.
When installed in a place receiving corrosive gases	Corrosive gases do not immediately affect the SERVOPACK but will eventually cause contactor-related devices to malfunction. Take appropriate action to prevent corrosive gases.
Others	Avoid installation in a hot and humid place or where excessive dust or iron powder is present in the air.

Orientation:

Install the SERVOPACK perpendicular to the wall as shown in the figure.

The SERVOPACK must be orientated as shown in the figure.

- Firmly secure the SERVOPACK through four mounting holes.

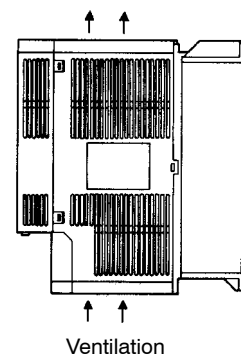

Ventilation

Installation method:

When installing multiple SERVOPACKs side by side in a control panel, observe the following installation method:

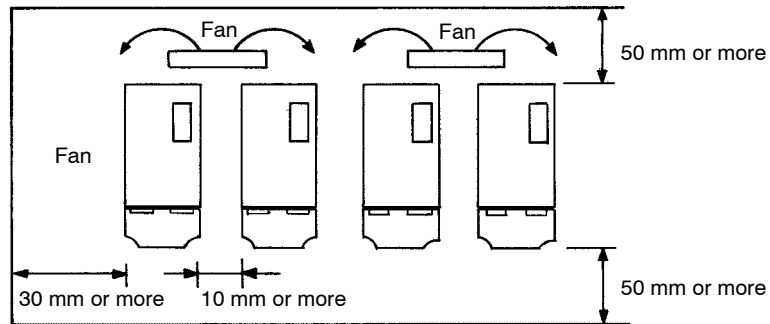

- a) Install SERVOPACK perpendicular to the wall so that the front panel (digital operator mounted face) faces outward.
- b) Provide sufficient space around each SERVOPACK to allow cooling by fan and natural convection.
- c) When installing SERVOPACKs side by side, provide at least 10 mm space between them and at least 50 mm space above and below them as shown in the figure above. Install cooling fans above the SERVOPACKs to prevent the temperature around each SERVOPACK from increasing excessively and also to maintain the temperature inside the control panel evenly.
- d) Maintain the following conditions inside the control panel:
 - Ambient temperature for SERVOPACK: 0 to 55°C
 - Humidity: 90%RH or less
 - Vibration: 4.9 m/s²
 - Condensation and freezing: None
 - Ambient temperature to ensure long-term reliability: 45°C or less

Power loss

Power loss of SERVOPACK is given below:

Power loss for rated output

SERVOPACK type	Output current (RMS value) A	Power loss in main circuit W	Power loss of regenerative resistor W	Power loss in control circuit W	Power loss in total W	
SGDB-03AD□	3.0	18	30	20	68	
SGDB-05AD□	3.8	27			77	
SGDB-07AD□	5.7	41			91	
SGDB-10AD□	7.6	55			105	
SGDB-15AD□	11.6	80			130	
SGDB-20AD□	18.5	120			170	
SGDB-30AD□	24.8	170			22	222
SGDB-44AD□	32.9	250	60	24	334	
SGDB-50AD□	28.2	260			344	
SGDB-60AD□	46.9	290	-	27	317	
SGDB-75AD□	54.7	330			357	
SGDB-1AAD□	58.6	360		30	30	390
SGDB-1EAD□	78.0	490				520

Note a) Power loss of regenerative resistor is allowable loss. If the loss exceeds the allowable loss, the regenerative resistor inside the SERVOPACK should be removed and connected externally. Because the model in which the regenerative resistor is externally connected falls into non-standard specification categories, contact YASKAWA for further information. For this non-standard type, "Y8" is appended to the end of the standard model number.

Line id: @zzzz

b) For SGDB-60AD to 1EAD□ models, the regenerative resistor is placed separately. The regenerative resistor unit provided from YASKAWA is described in *Section 3.8.4 Using Regenerative Resistor Units*. Its power loss for SGDB-60AD□ is 180W (type: JUSP-RA04), and for SGDB-75AD□ and -1EAD□ is 350W (type: JUSP-RA05).

2.3 Connection and Wiring

This section describes how to connect Σ -Series products to peripheral devices and explains a typical example of wiring the main circuit. It also describes an example of connecting to main host controllers.

2.3.1 Connecting to Peripheral Devices

This section shows a standard example of connecting Σ -Series products to peripheral devices and briefly explains how to connect to each peripheral device.

2

上正科技有限公司

購買、維修 此手冊零組件

電話： 037-466333

Email: service@repairtw.com

Line id: @zzzz

www.repairtw.com

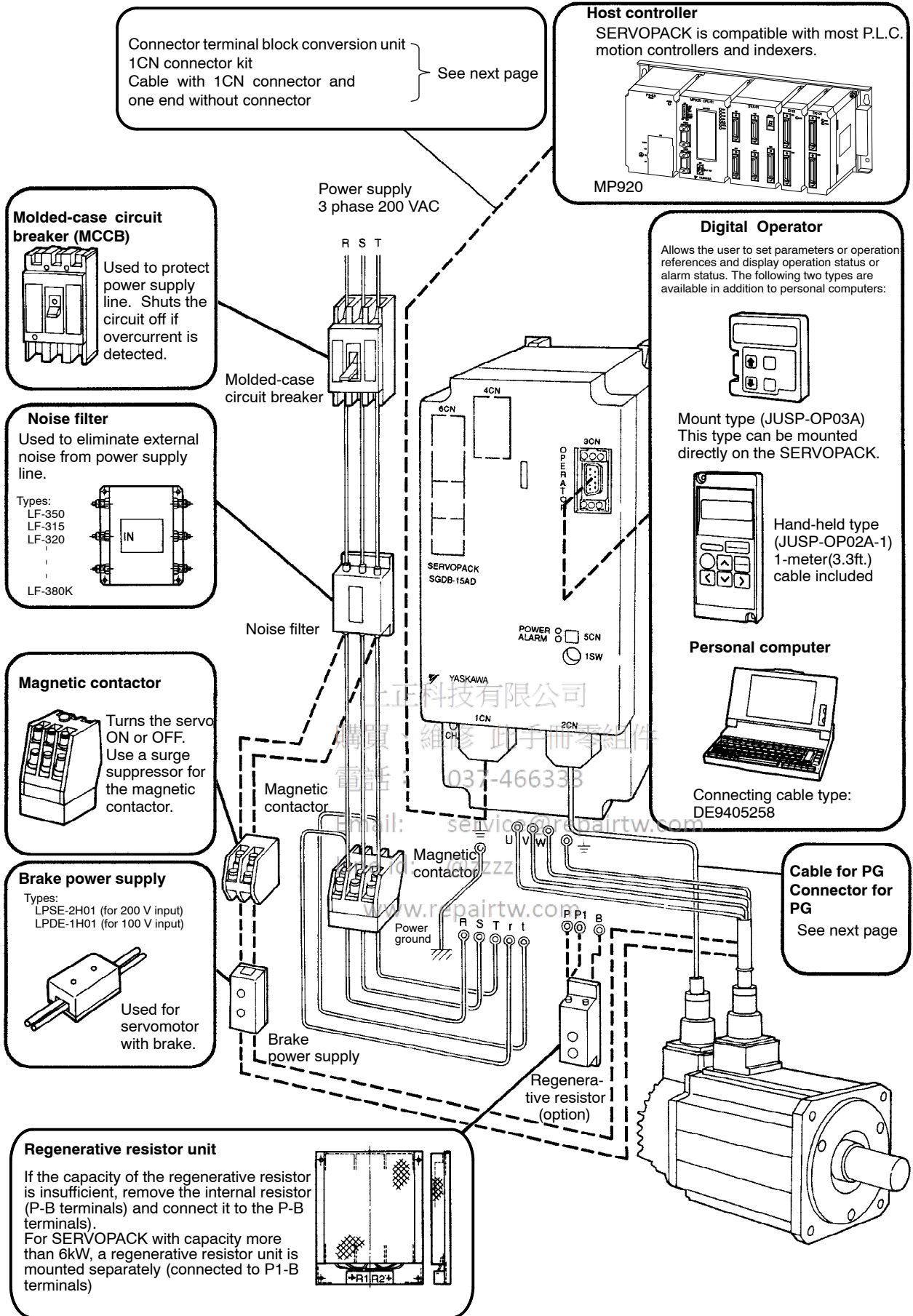

• Connector terminal block conversion unit (Type: JUSP-TA50P)

The terminal block allows connection to a host controller.

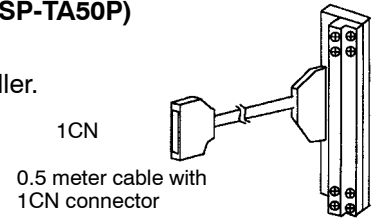

• Cable with 1CN connector and one end without connector

- 1m (3.3ft) DE9406969-1
- 2m (6.6ft) DE9406969-2
- 3m (9.8ft) DE9406969-3

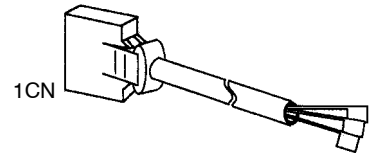

• 1CN connector kit (Type: DE9406970)



• Cable for PG

This cable is used to connect the encoder of servomotor to the SERVOPACK. The following three types of cables are available according to encoder types.

For models SGMG, SGMS, SGMD

- a) Cable with a single connector (without connector on encoder side)

Length	Cable type	
	Incremental	Absolute
3m (9.8ft)	DE9406971-1	DE9406972-1
5m (16.4ft)	DE9406971-2	DE9406972-2
10m (32.8ft)	DE9406971-3	DE9406972-3
15m (49.2ft)	DE9406971-4	DE9406972-4
20m (65.6ft)	DE9406971-5	DE9406972-5

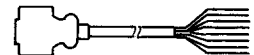

- b) Cable with connectors on both side (straight plug on encoder side)

Length	Cable type	
	Incremental	Absolute
3m (9.8ft)	DE9407234-1	DE9407236-1
5m (16.4ft)	DE9407234-2	DE9407236-2
10m (32.8ft)	DE9407234-3	DE9407236-3
15m (49.2ft)	DE9407234-4	DE9407236-4
20m (65.6ft)	DE9407234-5	DE9407236-5

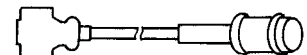

c) Cable with connectors on both side (L-shape plug on encoder side)

Length	Cable type	
	Incremental	Absolute
3m (9.8ft)	DE9407235-1	DE9407237-1
5m (16.4ft)	DE9407235-2	DE9407237-2
10m (32.8ft)	DE9407235-3	DE9407237-3
15m (49.2ft)	DE9407235-4	DE9407237-4
20m (65.6ft)	DE9407235-5	DE9407237-5

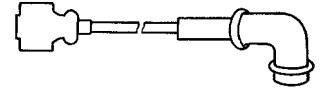

For models SGM, SGMP

a) Cable with connectors on both side

Length	Cable type	
	Incremental	Absolute
3m (9.8ft)	DP9320089-1	DP9320088-1
5m (16.4ft)	DP9320089-2	DP9320088-2
10m (32.8ft)	DP9320089-3	DP9320088-3
15m (49.2ft)	DP9320089-4	DP9320088-4
20m (65.6ft)	DP9320089-5	DP9320088-5

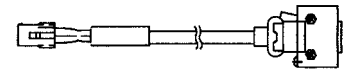

b) Cable with a single connector (without connector on SERVOPACK)

Length	Cable type	
	Incremental	Absolute
3m (9.8ft)	DP9320086-1	DP9320085-1
5m (16.4ft)	DP9320086-2	DP9320085-2
10m (32.8ft)	DP9320086-3	DP9320085-3
15m (49.2ft)	DP9320086-4	DP9320085-4
20m (65.6ft)	DP9320086-5	DP9320085-5

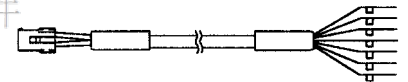

c) Cable without connectors

Length	Cable type	
	Incremental	Absolute
3m (9.8ft)	DP9400064-1	DP8409123-1
5m (16.4ft)	DP9400064-2	DP8409123-2
10m (32.8ft)	DP9400064-3	DP8409123-3
15m (49.2ft)	DP9400064-4	DP8409123-4
20m (65.6ft)	DP9400064-5	DP8409123-5

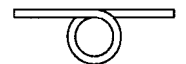

- Connector kit (DE9406973) for PG.
Connector on SERVOPACK side only

SERVOPACK
side

2CN

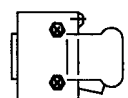

2.3.2 Main Circuit Wiring and Power ON Sequence

The following diagram shows a typical example of wiring the main circuit for Σ-Series products:

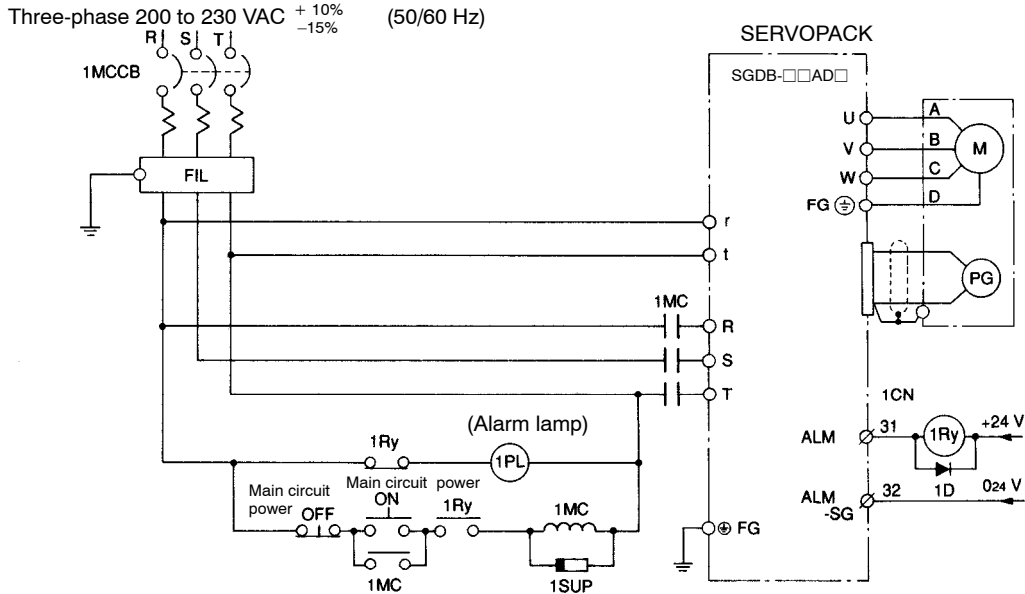

- 1MCCB: Circuit breaker (for inverter type)
- FIL: Noise filter
- 1MC: Contactor
- 1Ry: Relay
- 1PL: Lamp for display
- 1SUP: Surge suppressor
- 1D: Flywheel diode

購買、維修 此手冊零組件

The following table shows the name and description of each main circuit terminal:

Terminal Symbol	Name	Description
R, S, T	Main power input terminals	Three-phase 200 to 230 VAC $+10\%$ -15% , 50/60Hz
U, V, W	Motor connection terminal	Used to connect motor
r, t	Control power input terminals	Single phase 200 to 230 VAC $+10\%$ -15% , 50/60Hz
⊕ × 2	Ground terminal	Connected to earth. (For power ground and motor ground).
P, B	Regenerative resistor unit connection terminal	Normally, external connection is not required.
P1, B	Regenerative resistor unit connection terminal	Terminal used to connect regenerative resistor for SERVOPACK with power capacity more than 6 kW.
N	Main circuit minus side terminal.	Normally, external connection is not required.

Note P1 terminal is not available for SERVOPACK with power capacity less than 5 kW.

2

Form a power ON sequence as follows:

- Form a power ON sequence so that the power is turned OFF when a servo alarm signal is output. (See the circuit diagram shown on the previous page.)
- Hold down the power ON push-button for at least two seconds. The SERVOPACK outputs a servo alarm signal for approximately two seconds or less when the power is turned ON. This operation is required to initialize the SERVOPACK.

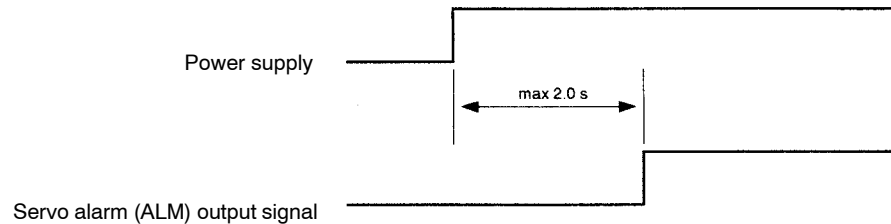

NOTE

- Do not wire power lines and signal lines in the same duct or bundle them together. Wire such that signal lines are kept apart from power lines by at least 30 cm.
- Twisted pair wire and multi-core twisted pair shielding wires should be used for signal lines, encoder (PG) feedback line.
The length for wiring is 3 m maximum for the reference input line, 20 m maximum for the PG feedback line.
- Do not touch the power terminal even if power was turned OFF. High voltage may still remain in SERVOPACK. Perform inspection only after the CHARGE lamp is OFF.
- Avoid frequently turning the power ON and OFF. Since the SERVOPACK has a capacitor in the power supply, a high charging current flows (for 0.2 second) when the power is turned ON. Therefore, frequently turning the power ON and OFF causes the main circuit devices (such as capacitors and fuses) to deteriorate, resulting in unexpected problems.

2.3.3 Connection to Host Controller

The SGDB SERVOPACK can be connected to the following host controllers. For details, refer to the technical documentation for the host controller.

- MP920
- GL-Series Positioning Module B2833
- GL-Series Positioning Module B2813
- OMRON Position Control Unit
- MITSUBISHI Positioning Unit

The following diagrams show connection examples with the host controllers manufactured by OMRON and MITSUBISHI.

■ Connection to OMRON Position Control Unit C500-NC222

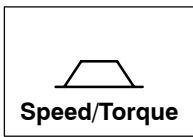

SERVOPACK for Speed/Torque Control

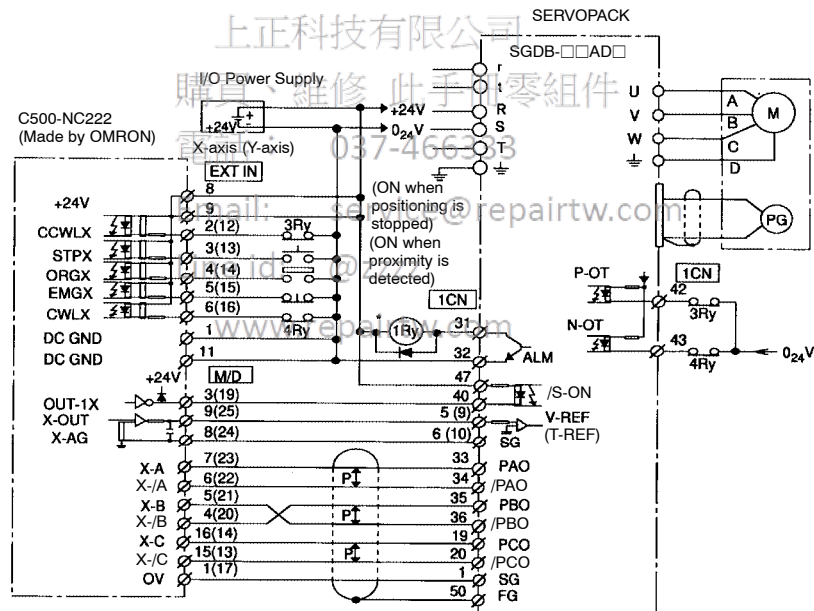

* These signals are output for approximately two seconds when the power is turned ON. Take this into consideration when designing a power ON sequence. Relay 1Ry is used to stop main circuit power supply to SERVOPACK.

Note The signals shown here are applicable only to OMRON Sequencer C500-NC222 and Yaskawa SERVOPACK SGDB-□□AD□.

■ Connection to OMRON Position Control Unit C500-NC112



SERVOPACK for Position Control

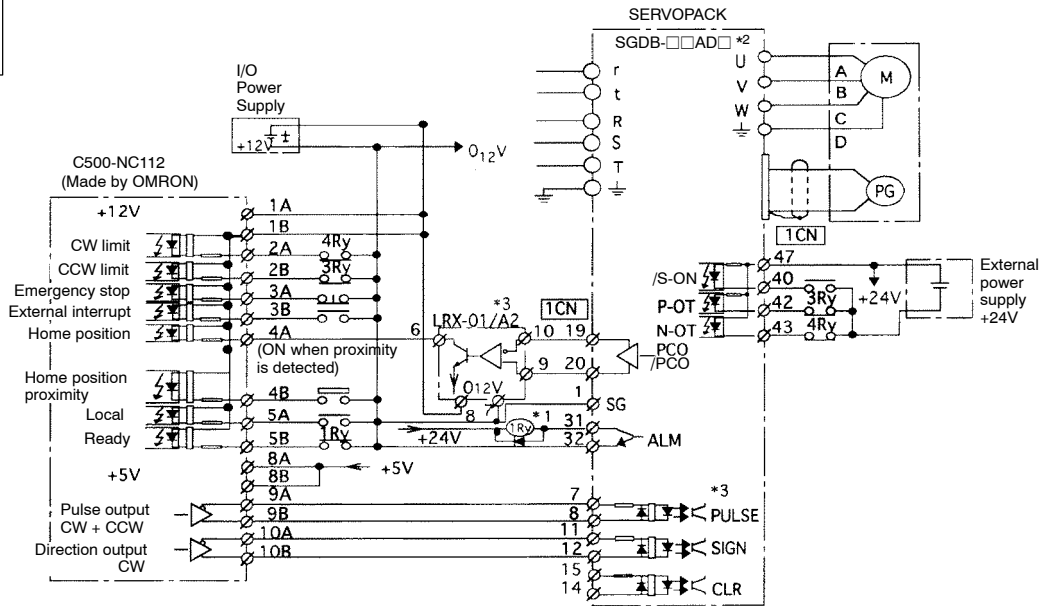

- *1 These signals are output for approximately two seconds when the power is turned ON. Take this into consideration when designing a power ON sequence. Relay 1Ry is used to stop main circuit power supply to SERVOPACK.
- *2 Change the Cn-02 setting as follows:
 Bit No. 3 = 1
 Bit No. 4 = 0
 Bit No. 5 = 0
- *3 Manufactured by Yaskawa Controls Co., Ltd.

Note The signals shown here are applicable only to OMRON Sequencer C500-NC112 and Yaskawa SERVOPACK SGDB-□□AD□.

Email: service@repairtw.com

Line id: @zzzz

www.repairtw.com



■ Connection to MITSUBISHI Positioning Unit AD72

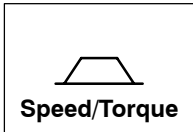

SERVOPACK for Speed/Torque Control

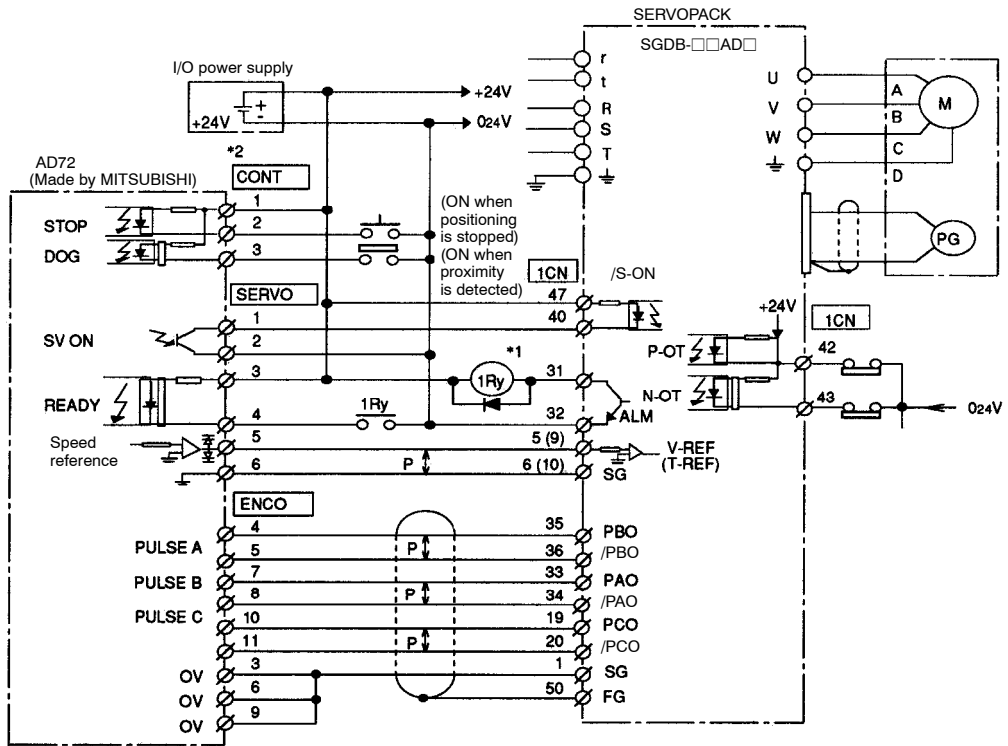

*1 These signals are output for approximately two seconds when the power is turned ON. Take this into consideration when designing a power ON sequence. Relay 1Ry is used to stop main circuit power supply to SERVOPACK.

*2 These pin numbers are the same for both X and Y axes.

Note The signals shown here are applicable only to MITSUBISHI Sequencer AD72 and Yaskawa SERVOPACK SGDB-□□AD□.

Email: service@repairtw.com

Line id: @zzzz

www.repairtw.com

■ Connection to MITSUBISHI Positioning Unit AD75

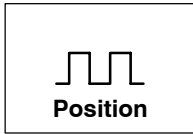

SERVOPACK for Position Control

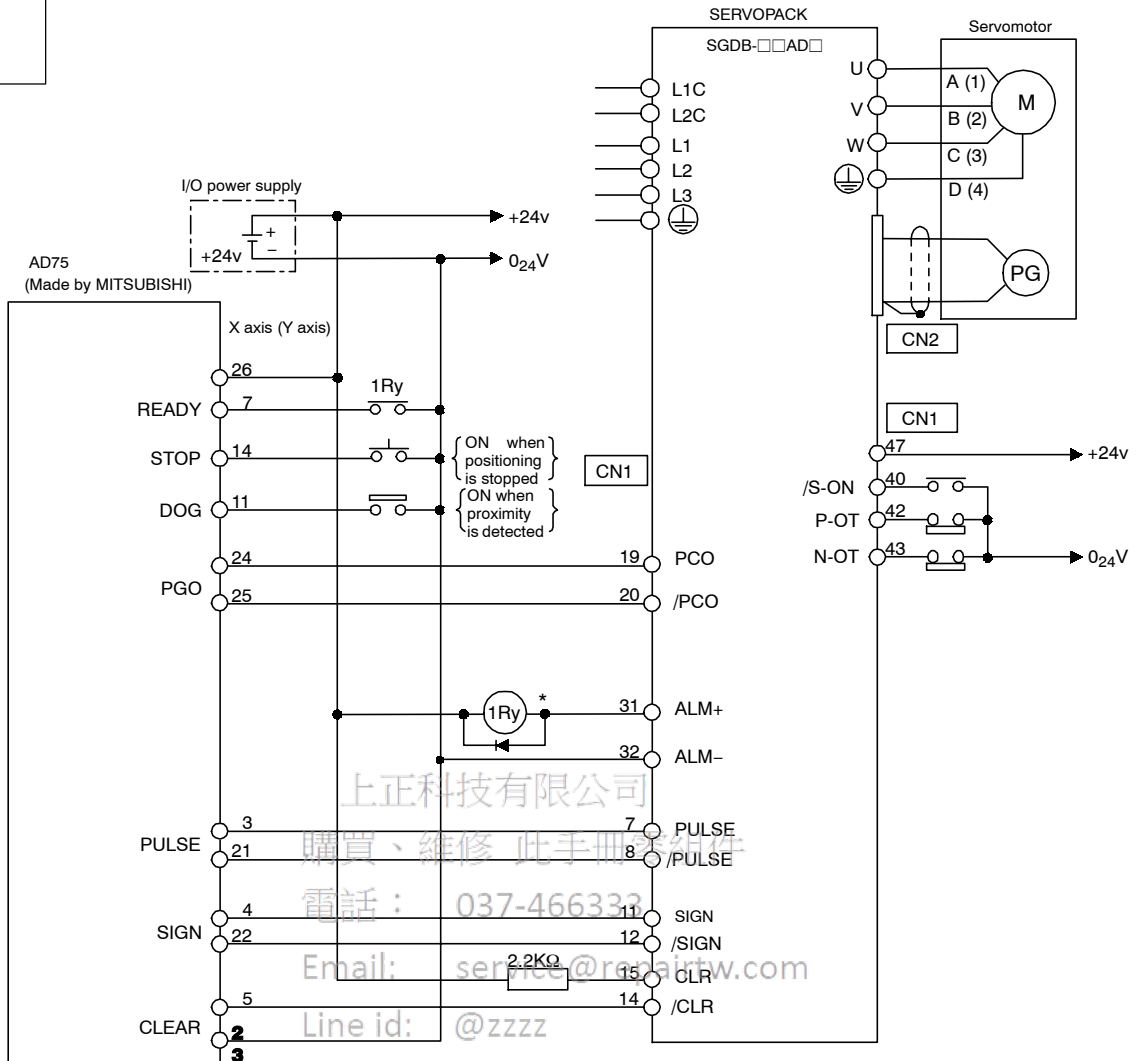

* These signals are output for approximately two seconds when the power is turned ON. Take this into consideration when designing a power ON sequence. Relay 1Ry is used to stop main circuit power supply to SERVOPACK.

Note The signals shown here are applicable only to MITSUBISHI Sequencer AD72 (B Type) and Yaskawa SERVOPACK SGDB-□□AD□.

2

2.4 Conducting a Test Run

This section describes how to conduct a full test run. The test run is divided into two steps. Complete a test run in step 1 first, then proceed to step 2.

2.4.1 Test Run in Two Steps

Conduct the test run when wiring is complete.

Generally, conducting a test run for servo drives can be difficult. However, by following the two steps described below, the test run can be performed safely and correctly.

NOTE To prevent accidents, initially conduct a test run only for a servomotor under no load (i.e., with all couplings and belts disconnected). Do not run the servomotor while it is connected to a machine.

The test run is divided here into steps 1 and 2.

Complete the test run in step 1 first, then proceed to step 2. The purposes of each step are described on the next page.

上正科技有限公司

購買、維修 此手冊零組件

電話： 037-466333

Email: service@repairtw.com

Line id: @zzzz

www.repairtw.com

Step 1: Conducting a test run for the motor without load . . . Check that the motor is wired correctly.

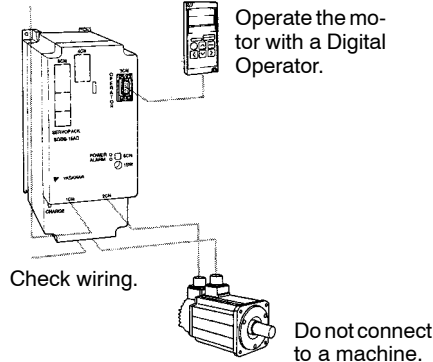

Conduct a test run with the motor shaft disconnected from the machine.

- Purpose:**
- To check power supply circuit wiring
 - To check motor wiring
 - To check I/O signal (1CN) wiring
- Outline:**
- Turn the power ON
 - Operate the motor with a digital operator
 - Check I/O signals (1CN)
 - Conduct a test run using I/O signals

2

Step 2: Conducting a test run with the motor and machine connected Adjust SERVOPACK according to machine characteristics.

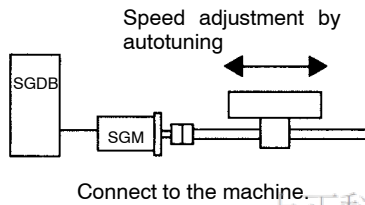

Connect to the machine and conduct a test run.

- Purpose:**
- To perform autotuning to adjust the motor according to machine characteristics
 - To match the speed and direction of rotation with the machine specifications
 - To check the final control mode

- Outline:**
- Perform autotuning
 - Adjust parameter settings
 - Record parameter settings

上正科技有限公司
購買、維修 此手冊零組件

電話： 037-466333

Email: service@repairtw.com

End of test run

Line id: @zzzz

www.repairtw.com

For servomotors with a brake, refer to *Section 2.4.4 Supplementary Information on Test Run* before starting a test run.

The following pages describe the test run procedure in detail.

2.4.2 Step 1: Conducting a Test Run for Motor without Load

Check that the motor is wired correctly.

If the motor fails to rotate properly during a servo drive test run, the cause most frequently lies with incorrect wiring.

Conduct a test run for the motor without load according to the procedure described below. For customers who use a servomotor with brake, refer to *Section 2.4.4 Supplementary Information on Test Run* before starting a test run.

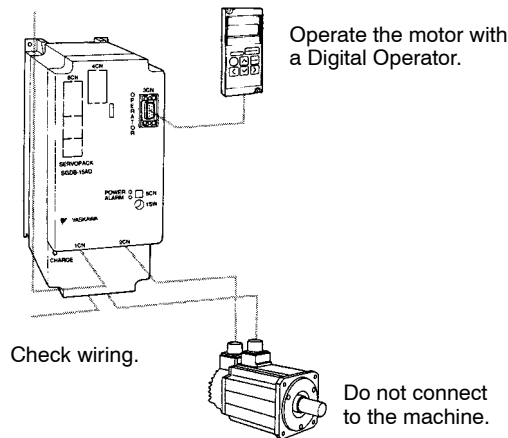

■ Securing the Servomotor

Secure the servomotor to mounting holes to prevent it from moving during operation. Alternatively, install the servomotor on the machine and disconnect couplings and belts.

Secure servomotor to mounting holes.

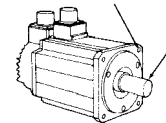

Do not connect anything to the motor shaft (no-load status).

■ Verifying the Wiring

Disconnect connector 1CN, then check the motor wiring in the power supply circuit. I/O signals (1CN) are not to be used so leave connector 1CN disconnected.

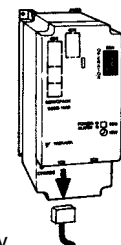

Disconnect connector 1CN

■ Turning the Power ON

Turn the SERVOPACK power ON. If the SERVOPACK is turned ON normally, the LED on the Digital Operator lights up as shown in the figure. Power is not supplied to the servomotor because the servo is OFF.

Normal display



Alternately displayed

Example of alarm display



Refer to Appendix D List of Alarm Displays.

If an alarm display appears on the LED as shown in the figure above, the power supply circuit, motor wiring or encoder wiring is incorrect. In this case, turn the power OFF, then correct the problem. For details, refer to *Appendix D List of Alarm Displays*.

■ Using the Digital Operator

Operate the motor with the Digital Operator. Check that the motor runs normally.

Refer to *Section 4.2.2 Operation Using the Digital Operator*.

Operation by Digital Operator

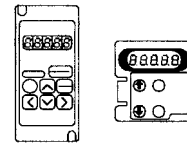

If an alarm occurs, the power supply circuit, motor wiring, or encoder wiring is incorrect.

■ Connecting Signal Lines

Connect connector 1CN as follows:

1. Turn the power OFF.
2. Connect connector 1CN.
3. Turn the power ON again.

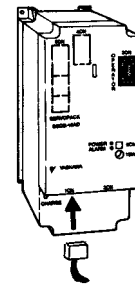

Connect connector 1CN.

■ Checking Input Signals.

Check the input signal wiring in monitor mode. For the checking method, refer to *Section 4.1.7 Operation in Monitor Mode*.

Internal status bit display (Un-05, Un-06)

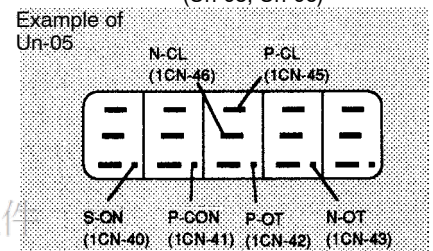

- Checking method
Turn each connected signal line ON and OFF to check that the monitor bit display changes accordingly.

The memory switch can be used to eliminate the need for external short-circuits in wiring (see pages 56 and 131).

Input Signal	ON/OFF	Monitor Bit Display
High level or open	OFF	Extinguished
0 V level	ON	Lit

If the signal lines below are not wired correctly, the motor fails to rotate. Always wire them correctly. (If signal lines are not to be used, short them as necessary.)

P-OT	1CN-42	Motor can rotate in forward direction when this input signal is at 0 V.
N-OT	1CN-43	Motor can reverse when this input signal is at 0 V.
S-ON	1CN-40	Servo is turned ON when this input signal is at 0 V. However, leave the servo in OFF status.

■ Turning Servo (Motor) ON

Turn the servo ON as follows:

1. Check that no reference has been input.

For speed/torque control:
V-REF (1CN-5) and T-REF (1CN-9) are at 0 V.

For position control:
PULS (1CN-7) and SIGN (1CN11) are fixed to L level.

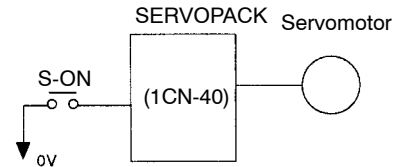

Turn the servo ON.

Note The parameter Cn-2B is used to set control modes (refer to Section 3.2 Setting Parameters According to Host Controller).

2. Turn the servo ON signal ON.

Display when servo is turned ON



Set/S-ON (1CN-40) to 0V. If normal, the motor starts and the Digital Operator displays the data as shown in the figure. If an alarm display appears, take appropriate action as described in Appendix D List of Alarm Displays.

■ Operating by Reference Input

The operating procedure varies according to the setting of parameter 'Control mode selection (Cn-2B)'.
 上正科技有限公司
 電話： 037-466333
 購買、維修 此手冊零組件
 Email: service@repairtw.com
 Line id: @zzzz
 www.repairtw.com

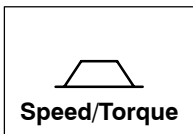

SERVOPACK for Speed/Torque

This section describes the standard speed control setting.

1. Gradually increase the speed reference input (V-REF, 1CN-5) voltage. The motor will rotate.

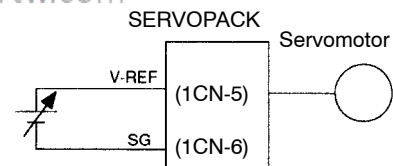

Servomotor rotates at a speed proportional to the reference voltage.

When a host controller such as a programmable controller performs position control, it may be difficult to directly input the speed reference voltage. In this case, constant voltage reference should be input once to ensure correct operation.

2. Check the following items in monitor mode (see page 191):

- Has a reference speed been input?
- Is the rotation speed the same value as the setting one?

- Does the reference speed match the actual motor speed?
- Does the motor stop when no reference is input?

Un-00	Actual motor speed
Un-01	Reference speed

- If the motor rotates at an extremely slow speed when 0 V is specified as the reference voltage, correct the reference offset value as described in *Section 4.2.4 Reference Offset Automatic Adjustment*
- To change motor speed or the direction of rotation, reset the parameters shown below.

Cn-03	Speed reference gain (see page 68)
Cn-02 bit 0	Reverse rotation mode (see page 54)

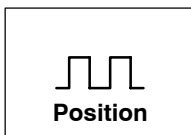

SERVOPACK for Position Control

- Set parameter Cn-02 so that the reference pulse form matches the host controller output form. (See page 183 for details on how to set parameters.)

Selecting reference pulse form (See page 70)

Cn-02	Bit 3
	Bit 4
	Bit 5

- Input slow speed pulses from the host controller and execute low-speed operation.

- Check the following items in monitor mode (see page 191):

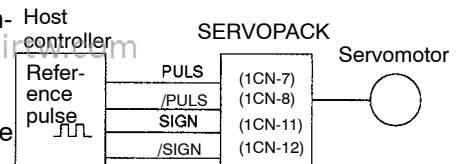

- Has a reference pulse been input?
- Is the motor speed as designed?
- Does the reference speed match the actual motor speed?
- Does the motor stop when no reference is input?

Un-00	Actual motor speed
Un-07	Reference pulse speed display
Un-08	Position error

- To change motor speed or the direction of rotation, reset the parameters shown as follows.

2.4.3 Step 2: Conducting a Test Run with the Motor Connected to the Machine

Cn-24,Cn-25	Electronic gear ratio (see page 81)
Cn-02 bit 0	Reverse rotation mode (see page 54)

If an alarm occurs or the motor fails to rotate during the above operation, connector 1CN wiring is incorrect or the parameter settings do not match the host controller specifications.

In this case, check the wiring and review the parameter settings, then repeat step 1.

Refer to *Appendix D List of Alarm Displays* and *Appendix C List of Parameters*.

This is all that is required to complete step 1 (conducting a test run for motor without load). Whenever possible, perform tuning associated with the host controller and other necessary adjustments in step 1 (before installing the motor on the machine).

2.4.3 Step 2: Conducting a Test Run with the Motor Connected to the Machine

After step 1 is complete, proceed to step 2 in which a test run is conducted with the motor connected to the machine. The purpose of step 2 is to adjust the SERVOPACK according to the machine characteristics.

Conduct a test run according to the procedure described below.

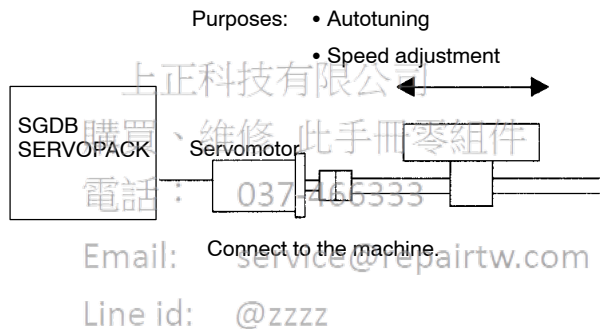

NOTE Before proceeding to step 2, repeat step 1 (conducting a test run for the motor without load) until you are fully satisfied that the test has been completed successfully. Operation faults that arise after the motor is connected to the machine not only damage the machine but may also cause an accident resulting in injury or death. Therefore, all items including parameters setting and wiring should be tested as conclusively as possible before step 1 is complete.

1. Check that power is OFF.
Turn the SERVOPACK power OFF.

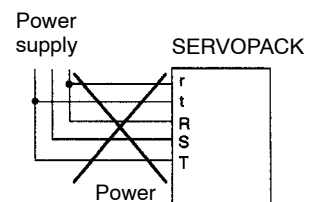

2. Connect the servomotor to the machine.
Refer to *Section 2.2.4 Installing the Servomotor*.

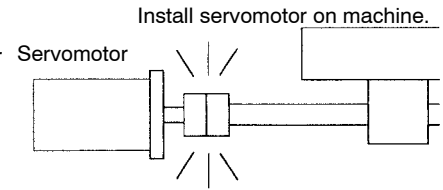

3. Perform autotuning.
Tune the SERVOPACK according to the machine characteristics. Refer to *Section 4.2.3 Autotuning*.

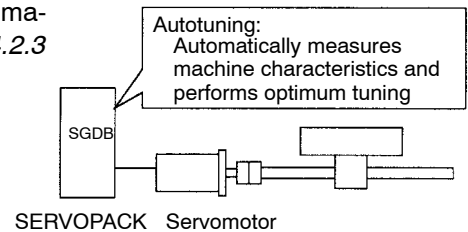

4. Operate by reference input.
As in step 1 (conducting a test run for motor without load), perform (8) *Operate by reference input* on page 44. Perform tuning associated with the host controller.

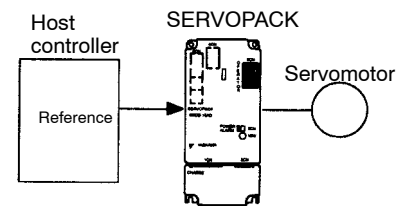

5. Set parameters and record the settings.
Set parameters as necessary. Record all the parameter settings for maintenance purposes.

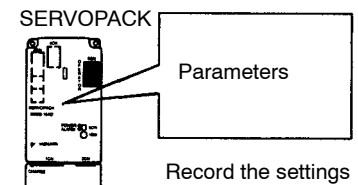

This is all that is required to conduct the test run.

Normally, the machine may cause much friction because of an insufficient running-in period. After a test run is complete, perform adequate running-in.

2.4.4 Supplementary Information on Test Run

In the following cases, always refer to the information described below before starting a test run:

- When using a servomotor with a brake
- When performing position control from the host controller

■ When Using a Servomotor with Brake

The brake prevents the motor shaft from rotating due to a backdriving torque. Such a torque may be created by an external force or the force of gravity acting on the load and may result in undesired motion or the load, should motor power be lost.

上正科技有限公司

購買、維修 此手冊零組件

電話：037-466333

Email: service@repairtw.com

Line id: @zzzz

www.repairtw.com

BASIC USES OF Σ-SERIES PRODUCTS

2.4.4 Supplementary Information on Test Run cont.

SERVOPACK uses the brake interlock output (BK) signal to control holding brake operation for a servomotor with brake.

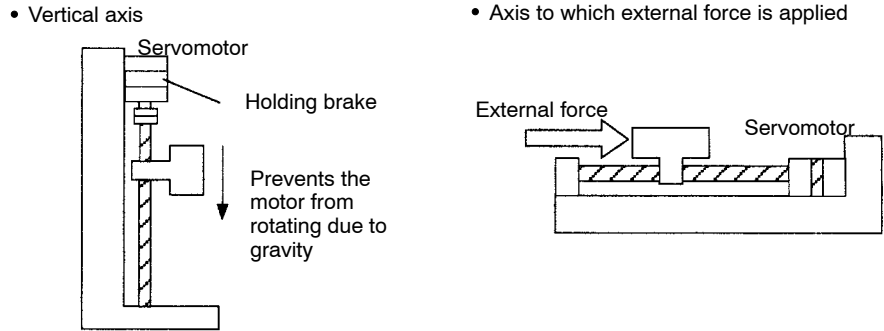

NOTE To prevent faulty operation caused by gravity (or external force), first check that the motor and holding brake operate normally with the motor disconnected from the machine. Then, connect the motor to the machine and conduct a test run.

For wiring of a servomotor with a brake, refer to *Section 3.4.4 Using Holding Brake*.

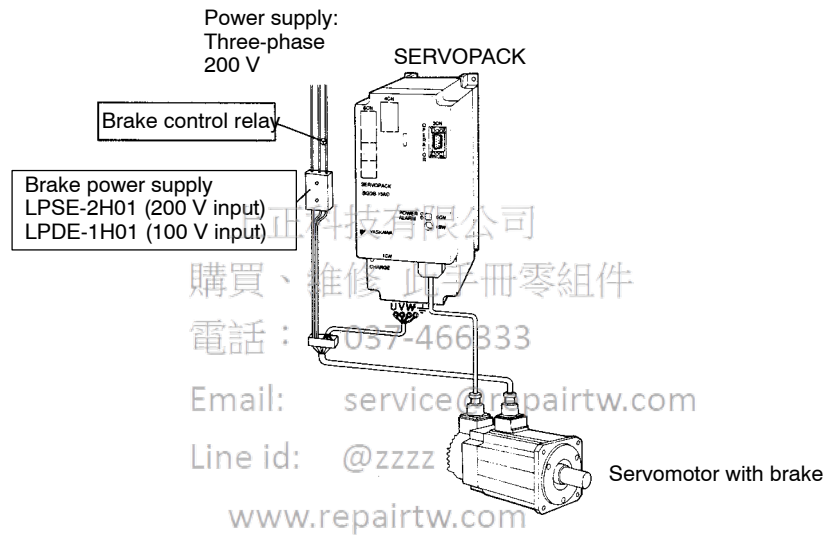

■ When Performing Position Control from the Host Controller

Check motor operation first and then conduct a test run as described in the table below.

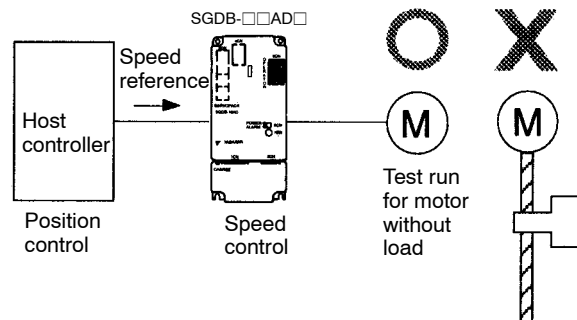

NOTE Check the motor operation with the motor disconnected from the machine. If the host controller does not perform position control correctly, the motor may run out of control.

Reference from Host Controller	Check Items	Check Method	Review Items
Jogging (constant-speed reference input from host controller)	Motor speed	Check the motor speed as follows: <ul style="list-style-type: none"> • Use the speed monitor (Un-00) of the digital operator. • Run the motor at low speed. For example, input a speed reference of 60 min^{-1} and check that the motor makes one revolution per one second. 	Check whether the speed reference gain value (parameter Cn-03) is correct.
Simple positioning	Number of motor revolutions	<ul style="list-style-type: none"> • Input a reference equivalent to one motor revolution and visually check that the motor shaft makes one revolution. 	Check whether the dividing ratio count (parameter Cn-0A) is correct.
Overtravel (when P-OT and N-OT signals are used)	Whether the motor stops rotating when P-OT and N-OT signals are input	<ul style="list-style-type: none"> • Check that the motor stops when P-OT and N-OT signals are input during continuous motor operation. 	If the motor does not stop, review the P-OT and N-OT wiring.

2

2.4.5 Minimum Parameters Required and Input Signals

This section describes the minimum parameters and input signals that must be set to conduct a test run.

For details on how to set each parameter, refer to *Section 4.1.6 Operation in Parameter Setting Mode*.

■ Parameters

- Basic parameters (common to speed, torque, position control)

Cn-11	Number of encoder pulses
Cn-01, bit E	Encoder selection
Cn-2A	Motor selection (check only in substance).
Cn-2C	PG power supply voltage change

- For speed/torque control

Cn-03	Speed reference gain (see page 68)
Cn-0A	Dividing ratio setting

- For position control

Cn-02 bits 3, 4 and 5	Reference pulse form selection (see page 70)
Cn-24	Electronic gear ratio (numerator) (see page 81)
Cn-25	Electronic gear ratio (denominator) (see page 81)

When these parameters (except for Cn-03) are changed, always turn the power OFF, then back ON. This makes the new setting valid.

If the specified direction of rotation differs from the actual direction of rotation, the wiring may be incorrect. In this case, recheck the wiring and correct it accordingly. Then, if the direction of rotation is to be reversed, set the following parameter:

Cn-02 (bit 0)	Reverse rotation mode (see page 54)
---------------	-------------------------------------

After changing the Cn-02 setting, always turn the power OFF, then ON, to make the new setting valid.

■ Input Signals

The following table lists the minimum input signals required to conduct a test run. For details of each input signal, refer to the relevant page.

Signal Name	Pin Number	Function
/S-ON (servo ON)	1CN-40	Switching between motor ON and OFF status. The memory switch can be used to eliminate the need for external short-circuit wiring (see page 131).
P-OT (forward rotation prohibited)	1CN-42	Overtravel limit switch The memory switch can be used to eliminate the need for external short-circuit wiring (see page 56).
N-OT (reverse rotation prohibited)	1CN-43	

www.repairtw.com

APPLICATIONS OF Σ -SERIES PRODUCTS

3

This chapter is prepared for readers who wish to learn more about the applications of Σ -series products after fully understanding *Chapter 2 Basic Uses of Σ -series Products*. It explains how to set parameters for each purpose and how to use each function. Read the applicable sections according to your requirements.

3

3.1	Setting Parameters According to Machine Characteristics	54
3.1.1	Changing the Direction of Motor Rotation	54
3.1.2	Setting the Overtravel Limit Function	56
3.1.3	Restricting Torque	59
3.2	Setting Parameters According to Host Controller	64
3.2.1	Inputting Speed Reference	64
3.2.2	Inputting Position Reference	68
3.2.3	Using Encoder Outputs	73
3.2.4	Using Contact I/O Signals	77
3.2.5	Using Electronic Gear	79
3.2.6	Using Contact Input Speed Control	83
3.2.7	Using Torque Control	87
3.2.8	Using Torque Feed-forward Function	94
3.2.9	Using Torque Restriction by Analog Voltage Reference	95
3.2.10	Using the Reference Pulse Inhibit Function (INHIBIT)	97
3.2.11	Using the Reference Pulse Input Filter Selection Function	98
3.2.12	Using the Analog Monitor	99
3.3	Setting Up the Σ SERVOPACK	100
3.3.1	Setting Parameters	100
3.3.2	Setting the Jog Speed	101
3.3.3	Setting the Number of Encoder Pulses	102
3.3.4	Setting the Motor Type	103
3.3.5	Adjusting the Encoder Supply Voltage	104

3.4	Setting Stop Mode	105
3.4.1	Adjusting Offset	105
3.4.2	Using Dynamic Brake	106
3.4.3	Using Zero-Clamp	107
3.4.4	Using Holding Brake	108
3.5	Running the Motor Smoothly	113
3.5.1	Using the Soft Start Function	113
3.5.2	Using the Smoothing Function	114
3.5.3	Adjusting Gain	114
3.5.4	Adjusting Offset	115
3.5.5	Setting the Torque Reference Filter Time Constant	115
3.6	Minimizing Positioning Time	117
3.6.1	Using Autotuning Function	117
3.6.2	Setting Servo Gain	117
3.6.3	Using Feed-forward Control	119
3.6.4	Using Proportional Control	119
3.6.5	Setting Speed Bias	120
3.6.6	Using Mode Switch	121
3.7	Forming a Protective Sequence	127
3.7.1	Using Servo Alarm Output and Alarm Code Output	127
3.7.2	Using Servo ON Input Signal	130
3.7.3	Using Positioning Complete Signal	131
3.7.4	Using Speed Coincidence Output Signal	134
3.7.5	Using Running Output Signal	136
3.7.6	Using OL Warning and Alarm Output Signals	138
3.7.7	Using Servo Ready Output Signal	140
3.7.8	Handling of Power Loss	141
3.8	Special Wiring	142
3.8.1	Wiring Instructions	142
3.8.2	Wiring for Noise Control	144
3.8.3	Using More Than One Servo Drive	149
3.8.4	Using Regenerative Resistor Units	151
3.8.5	Using an Absolute Encoder	152
3.8.6	Extending an Encoder Cable	162
3.8.7	Using SGDB SERVOPACK with High Voltage Line	164
3.8.8	Connector Terminal Layouts	166

Before Reading this Chapter

This chapter describes how to use each 1CN connector I/O signal for the SGDB SERVO-PACK and how to set the corresponding parameter.

Refer to corresponding section described below as necessary.

- A list of I/O signals of 1CN connector : *Appendix B List of I/O Signals*
- Terminal arrangement for I/O signals of 1CN connector : *Section 3.8.8 Connector Terminal Layouts*
- A list of parameters : *Appendix C List of Parameters*
- How to set parameters : *Section 4.1.6 Operation in Parameter Setting Mode*

Parameters are divided into the following two types.

Memory switch Cn-01 and Cn-02	Set each bit to ON or OFF to select a function.
Constant setting Cn-03 and later	Set a numerical value such as a torque limit value or speed loop gain.

上正科技有限公司

購買、維修 此手冊零組件

電話： 037-466333

Email: service@repairtw.com

Line id: @zzzz

www.repairtw.com

3.1 Setting Parameters According to Machine Characteristics

This section describes how to set parameters according to the dimensions and performance of the machine to be used.

3.1.1 Changing the Direction of Motor Rotation

This SERVOPACK provides a reverse rotation mode in which the direction of rotation can be reversed without altering the servomotor wiring. With the standard setting, forward rotation is defined as counterclockwise (ccw) rotation viewed from the drive end.

If reverse rotation mode is used, the direction of motor rotation can be reversed without other items being changed. The direction (+/-) of axial motion is reversed.

	Standard Setting	Reverse Rotation Mode
Forward Run Reference	<p>Encoder output from SERVOPACK</p> <p>PAO (Phase A)</p> <p>PBO (Phase B)</p>	<p>Encoder output from SERVOPACK</p> <p>PAO (Phase A)</p> <p>PBO (Phase B)</p>
Reverse Run Reference	<p>Encoder output from SERVOPACK</p> <p>PAO (Phase A)</p> <p>PBO (Phase B)</p>	<p>Encoder output from SERVOPACK</p> <p>PAO (Phase A)</p> <p>PBO (Phase B)</p>

■ Setting Reverse Rotation Mode

Reverse rotation mode can be set in either of the following two ways. Normally, method 1 is easier to use.

Method 1: Setting Memory Switch

Set bit 0 of memory switch Cn-02 to select reverse rotation mode.

Cn-02 Bit 0	Rotation Direction Selection	Factory Setting: 0	For Speed/Torque Control and Position Control
--------------------	------------------------------	--------------------	---

Set the direction of rotation.

Setting	Meaning
0	Forward rotation is defined as counterclockwise rotation when viewed from the drive end. (Standard setting)
1	Forward rotation is defined as clockwise rotation when viewed from the drive end. (Reverse rotation mode)

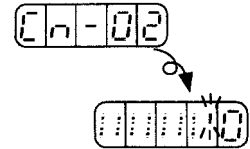

3

Method 2: Shorting the Wiring in the 2CN Connector

Reverse rotation mode can be set for the 2CN connector for the encoder. This method is used to standardize parameter settings without using the memory switch.

In this case, reverse rotation mode is set regardless of the memory switch setting.

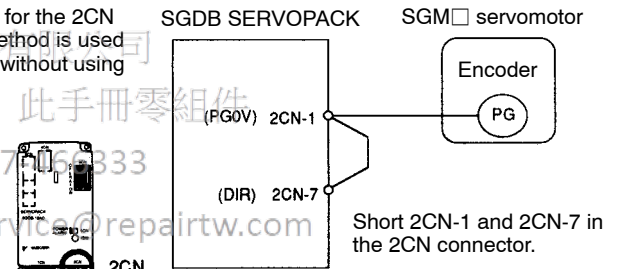

Short 2CN-1 and 2CN-7 in the 2CN connector.

購買、維修 此手冊零組件
 電話: 037-06-8333
 Email: service@repairtw.com
 Li...@zzzz
 www.repairtw.com

3.1.2 Setting the Overtravel Limit Function

The overtravel limit function forces the moving part of the machine to stop when it exceeds the movable range.

■ Using the Overtravel Limit Function

To use the overtravel limit function, connect the following input signal terminals correctly.

→ Input P-OT 1CN-42	Forward Rotation Prohibited (Forward Overtravel)	For Speed/Torque Control and Position Control
→ Input N-OT 1CN-43	Reverse Rotation Prohibited (Reverse Overtravel)	For Speed/Torque Control and Position Control

Input terminals for overtravel limit switch.

For linear motion, connect a limit switch to prevent damage to the machine.

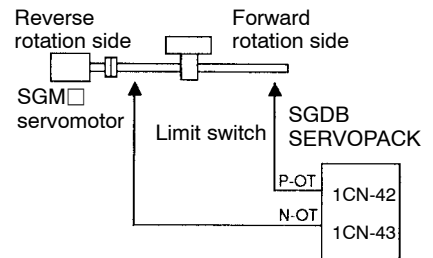

P-OT	ON: 1CN-42 is at low level.	Forward rotation allowed. Normal operation status.
	OFF: 1CN-42 is at high level.	Forward rotation prohibited (reverse rotation allowed).
N-OT	ON: 1CN-43 is at low level.	Reverse rotation allowed. Normal operation status.
	OFF: 1CN-43 is at high level.	Reverse rotation prohibited (forward rotation allowed).

Email: service@repairtw.com

■ Specifying whether Input Signals for Overtravel are to be Used

Use the following parameters (memory switch) to specify whether input signals for overtravel are to be used.

Cn-01 Bit 2	Use of P-OT Input Signal	Factory Setting: 0	For Speed/Torque Control and Position Control
Cn-01 Bit 3	Use of N-OT Input Signal	Factory Setting: 0	For Speed/Torque Control and Position Control

Specifies whether the P-OT input signal for prohibiting forward rotation at overtravel (1CN-42) is to be used and whether the N-OT input signal for prohibiting reverse rotation at overtravel (1CN-43) is to be used.

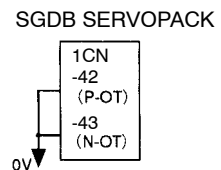

Specifies "1" when external short-circuit wiring is to be omitted.

The short-circuit wiring shown in the figure can be omitted when P-OT and N-OT are not used.

Bit	Setting	Meaning
Bit 2	0	Uses the P-OT input signal for prohibiting forward rotation. (Forward rotation is allowed when 1CN-42 is at 0 V.)
	1	Does not use the P-OT input signal for prohibiting forward rotation. (Forward rotation is always allowed. This has the same effect as shorting 1CN-42 to 0 V.)
Bit 3	0	Uses the N-OT input signal for prohibiting reverse rotation. (Reverse rotation is prohibited when 1CN-43 is open. Reverse rotation is allowed when 1CN-43 is at 0 V.)
	1	Does not use the N-OT input signal for prohibiting reverse rotation. (Reverse rotation is always allowed. This has the same effect as shorting 1CN-43 to 0 V.)

■ Setting the Motor Stopping Method

If the P-OT and N-OT input signals are used, set the following parameters to specify how to stop the motor.

Cn-01 Bit 8	How to Stop Motor at Overtravel	Factory Setting: 0	Invalid for Torque Control
Cn-01 Bit 9	Operation to be Performed when Motor Stops after Overtravel	Factory Setting: 0	Invalid for Torque Control

3

- Inputs signal for prohibiting forward rotation (P-OT, 1CN-42)
- Inputs signal for prohibiting reverse rotation (N-OT, 1CN-43)

Specify how to stop the motor when either of the above signals is input.

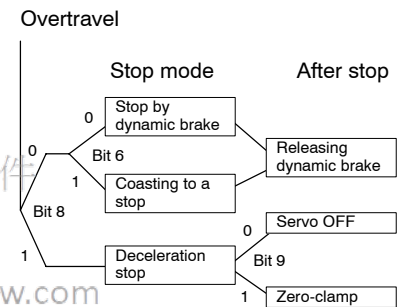

	Setting	Meaning
Cn-01 bit 8	0	Stop the motor in the same way as when the servo is turned OFF. The motor is stopped by dynamic brake or coasts to a stop. Either of these stop modes is selected by setting bit 6 of Cn-01.
	1	Stop the motor by decelerating it with the preset torque. Preset value: Cn-06 (EMGTRQ) emergency stop torque

If deceleration stop mode is selected, specify the operation to be done after the motor stops.

	Setting	Meaning
Cn-01 bit 9	0	Turns the servo OFF when the motor stops in deceleration stop mode.
	1	Causes the motor to enter zero-clamp status after it stops in deceleration stop mode.

In torque control mode, the motor stops in the same way as when the servo is turned OFF, regardless of the bit 8 setting.

3.1.2 Setting the Overtravel Limit Function

Cn-06	EMGTRQ Emergency Stop Torque	Unit: %	Setting Range: 0 to Maximum Torque	Factory Setting: Maximum Torque	Valid when Cn-01 bit 8 = 1
--------------	------------------------------------	------------	---	--	-------------------------------

Specifies the stop torque to be applied at overtravel when the input signal for prohibiting forward or reverse rotation is to be used.

Specifies a torque value in terms of a percentage of the rated torque.

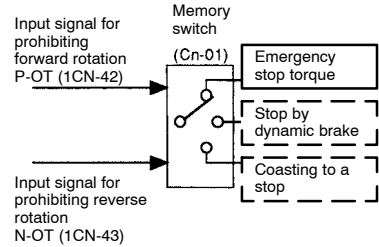

3

Cn-01 Bit 6	How to Stop Motor at Servo OFF	Factory Setting: 0	
Cn-01 Bit 7	Operation to Be Performed when Motor Stops after Servo OFF	Factory Setting: 1	Invalid for 2.0 kW or more

The SERVOPACK enters servo OFF status when:

- Servo ON input signal (/S-ON, 1CN-40) is turned OFF.
- Servo alarm arises.
- Power is turned OFF.

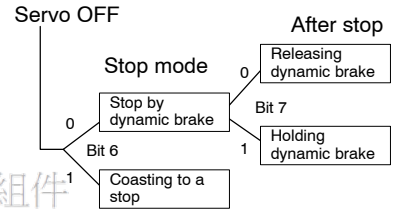

Dynamic brake is a function that electrically applies brakes by using a resistor to consume motor rotation energy.

Specify how to stop the motor when one of the above events occurs during operation.

	Setting	Meaning
Cn-01 bit 6	0	Stops the motor by dynamic brake.
	1	Causes the motor to coast to a stop. The motor power is OFF and stops due to machine friction.

If dynamic brake stop mode is selected, specify the operation to be performed when the motor stops.

	Setting	Meaning
Cn-01 bit 7	0	Releases dynamic brake after the motor stops.
	1	Does not release dynamic brake even after the motor stops.

Note For SERVOPACKs of 2.0 kW or more, bit 7 of Cn-01 can be set to 0 only.

3.1.3 Restricting Torque

The SERVOPACK can provide the following torque control:

- Torque restriction
 - Level 1: To restrict the maximum output torque to protect the machine or workpiece
 - Level 2: To restrict torque after the motor moves the machine to a specified position
- Torque control
 - Level 3: To always control output torque, not speed
 - Level 4: To alternately use speed control and torque control

This section describes how to use levels 1 and 2 of the torque restriction function.

■ How to Set Level 1: Internal Torque Limit

The maximum torque is restricted to the values set in the following parameters.

Cn-08	TLMTF Forward Rotation Torque Limit	Unit: %	Setting Range: 0 to 800	Factory Setting: 800	For Speed/Torque Control and Position Control
Cn-09	TLMTR Reverse Rotation Torque Limit	Unit: %	Setting Range: 0 to 800	Factory Setting: 800	For Speed/Torque Control and Position Control

Sets the maximum torque values for forward rotation and reverse rotation, respectively.

Sets these parameters when torque must be restricted according to machine conditions.

This torque restriction function always monitors torque, and outputs the signal shown on the right when the limit value is reached.

Specifies a torque limit value in terms of a percentage of the rated torque.

If a value higher than the maximum torque is set, the maximum torque value is used.

Output Signal for Torque Restriction Function

- /CLT
- Monitor mode (Un-06) bit 4

Parameter Setting:
(Cn-2D) = □□3, □3□, 3□□

Example of Use: Machine Protection

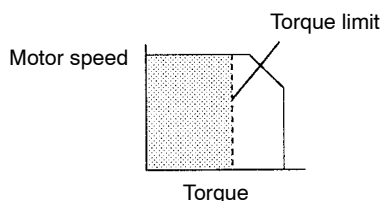

Note that too small a torque limit value will result in torque shortage at acceleration or deceleration.

- Using /CLT Signal

This section describes how to use contact output signal /CLT as a torque limit output signal.

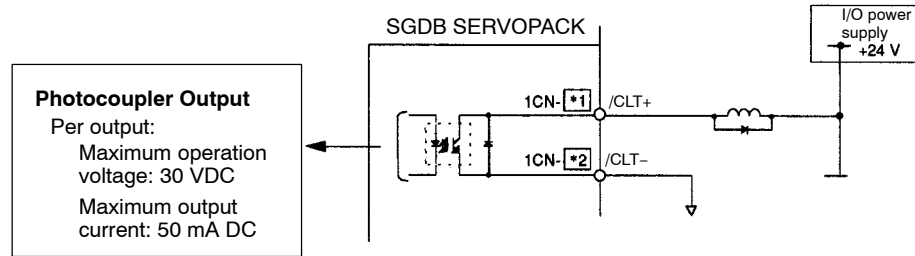

Photocoupler Output
 Per output:
 Maximum operation voltage: 30 VDC
 Maximum output current: 50 mA DC

3

Output → /CLT 1CN-*1	Torque Limit Output	For Speed/Torque Control and Position Control
-----------------------------	---------------------	---

This signal indicates whether motor output torque (current) is being restricted.

ON status: The circuit between 1CN-*1 and 1CN-*2 is closed. 1CN-*1 is at low level.	Motor output torque is being restricted. (Internal torque reference is greater than the preset value.)
OFF status: The circuit between 1CN-*1 and 1CN-*2 is open. 1CN-*1 is at high level.	Motor output torque is not being restricted. (Internal torque reference is equal to or below the preset value.)

Preset Value: Cn-08 (TLMTF)
 Cn-09 (TLMTR)
 Cn-18 (CLMIF) : P-CL input only
 Cn-19 (CLMIR) : N-CL input only

Cn-2D	Output Signal Selection	Factory Setting: 210	For Speed/Torque Control and Position Control
--------------	-------------------------	----------------------	---

www.repairtw.com

Specifies the terminal to which /CLT is to be output.

Setting	Output terminals (1CN-)	
	*1	*2
1s place = 3	25	26
10s place = 3	27	28
100s place = 3	29	30

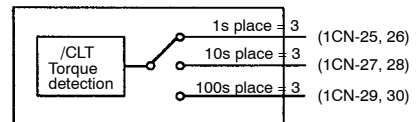

■ How to Set Level 2: External Torque Limit

First, use a contact input signal to make the torque (current) limit value set in the parameter valid. Torque limit can be set separately for forward and reverse rotation.

To use this function, always set bit 2 of memory switch Cn-02 to 0 (standard setting). The contact input speed control function cannot be used.

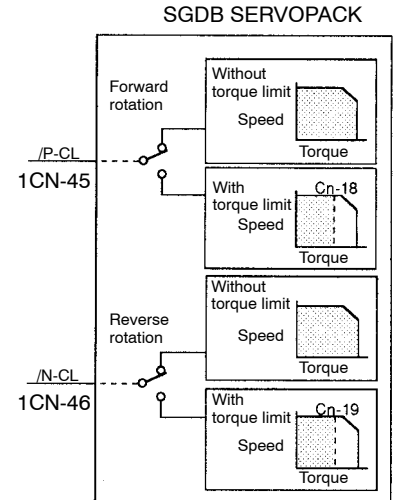

P-CL	ON: 1CN-45 is at low level.	Torque restriction applies during forward rotation.	Limit value: Cn-18
	OFF: 1CN-45 is at high level.	Torque restriction does not apply during forward rotation.	
N-CL	ON: 1CN-46 is at low level.	Torque restriction applies during reverse rotation.	Limit value: Cn-19
	OFF: 1CN-46 is at high level.	Torque restriction does not apply during reverse rotation.	

3

Output Signal for Torque Restriction Function

This torque restriction function outputs the signal shown on the right.

- /CLT
 - Status indication mode bit data
 - Monitor mode Un-05 bit 4
- Parameter Setting:
Cn-2D = □□3, □3□, 3□□

Examples of Use:

- Forced stopping
- Holding workpiece by robot

Cn-18	CLMIF Forward External Torque Limit	Unit: %	Setting Range: 0 to 800	Factory Setting: 100	For Speed/Torque Control and Position Control
Cn-19	CLMIR Reverse External Torque Limit	Unit: %	Setting Range: 0 to 800	Factory Setting: 100	For Speed/Torque Control and Position Control

Sets a torque limit value when torque is restricted by external contact input. This function is valid when Cn-2B is set to 0, 1, 2, 7, 8, 9, 10, 11.

When /P-CL (1CN-45) is input	Applies torque restriction as specified in Cn-18
When /N-CL (1CN-46) is input	Applies torque restriction as specified in Cn-19

For torque restriction by analog voltage reference, refer to Section 3.2.9 Using Torque Restriction by Analog Voltage Reference.

3.1.3 Restricting Torque

- Using /P-CL and /N-CL Signals

This section describes how to use input signals /P-CL and /N-CL as torque limit input signals.

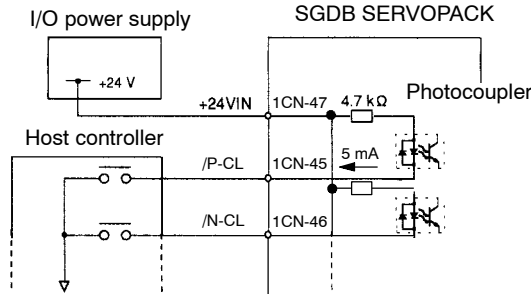

3

→ Input /P-CL 1CN-45	Forward External Torque Limit Input (Speed Selection 1)	For Speed/Torque Control and Position Control
→ Input /N-CL 1CN-46	Reverse External Torque Limit Input (Speed Selection 2)	For Speed/Torque Control and Position Control

These signals are for forward and reverse external torque (current) limit input.

This function is useful in stopping.

Output Signal for Torque Restriction Function

- /CLT
- Status indication mode bit data
- Monitor mode Un-05 bit 4
- Parameter Setting:
Cn-2D = □□3, □3□, 3□□

P-CL	ON: 1CN-45 is at low level.	Torque restriction applies during forward rotation.	Limit value: Cn-18
	OFF: 1CN-45 is at high level.	Torque restriction does not apply during forward rotation. Normal operation status.	
N-CL	ON: 1CN-46 is at low level.	Torque restriction applies during reverse rotation.	Limit value: Cn-19
	OFF: 1CN-46 is at high level.	Torque restriction does not apply during reverse rotation. Normal operation status.	

The signal shown on the above are output while torque is being restricted.

Note This function is changed to another function depending on the setting of memory switch Cn-2B (see below).

To use /P-CL and /N-CL as torque limit input signals, set the following constant.

Cn-2B	Control Mode Selection	Factory Setting: 0	For Speed/Torque Control and Position Control
--------------	------------------------	--------------------	---

Prohibits the contact input speed control function.

If the contact input speed control function is used, the contents of the input signals shown below will change.

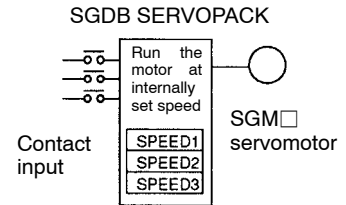

After this memory switch is reset, the meanings of the following signals will also change:

Monitor mode (Un-05) bit 7 and bit 8

Setting	Meaning	Input Signal																				
0, 1, 2, 7, 8, 9, 10, 11	Does not use the contact input speed control function.	<table border="1"> <tr> <td>/P-CON (1CN-41)</td> <td colspan="3">Used to switch between P control and PI control and to perform other functions.</td> </tr> <tr> <td>/P-CL (1CN-45)</td> <td colspan="3">Used for forward external torque limit input</td> </tr> <tr> <td>/N-CL (1CN-46)</td> <td colspan="3">Used for reverse external torque limit input</td> </tr> </table>	/P-CON (1CN-41)	Used to switch between P control and PI control and to perform other functions.			/P-CL (1CN-45)	Used for forward external torque limit input			/N-CL (1CN-46)	Used for reverse external torque limit input										
/P-CON (1CN-41)	Used to switch between P control and PI control and to perform other functions.																					
/P-CL (1CN-45)	Used for forward external torque limit input																					
/N-CL (1CN-46)	Used for reverse external torque limit input																					
3, 4, 5, 6	Uses the contact input speed control function.	<p style="text-align: right;">0: OFF, 1: ON</p> <table border="1"> <thead> <tr> <th>/P-CON</th> <th>/P-CL</th> <th>/N-CL</th> <th>Speed Setting</th> </tr> </thead> <tbody> <tr> <td>Direction of rotation 0: Forward 1: Reverse</td> <td>0</td> <td>0</td> <td>0 reference and so on</td> </tr> <tr> <td></td> <td>0</td> <td>1</td> <td>Cn-1F (SPEED1)</td> </tr> <tr> <td></td> <td>1</td> <td>1</td> <td>Cn-20 (SPEED2)</td> </tr> <tr> <td></td> <td>1</td> <td>0</td> <td>Cn-21 (SPEED3)</td> </tr> </tbody> </table>	/P-CON	/P-CL	/N-CL	Speed Setting	Direction of rotation 0: Forward 1: Reverse	0	0	0 reference and so on		0	1	Cn-1F (SPEED1)		1	1	Cn-20 (SPEED2)		1	0	Cn-21 (SPEED3)
/P-CON	/P-CL	/N-CL	Speed Setting																			
Direction of rotation 0: Forward 1: Reverse	0	0	0 reference and so on																			
	0	1	Cn-1F (SPEED1)																			
	1	1	Cn-20 (SPEED2)																			
	1	0	Cn-21 (SPEED3)																			

3.2 Setting Parameters According to Host Controller

This section describes how to connect a Σ-series Servo to a host controller and how to set parameters.

3.2.1 Inputting Speed Reference

Input a speed reference by using the following input signal "speed reference input." Since this signal can be used in different ways, set the optimum reference input for the system to be created.

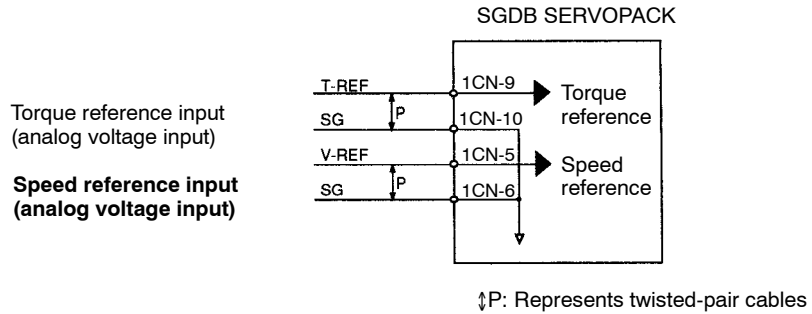

→ Input V-REF	Speed Reference Input	For Speed Control Only
→ Input SG	Signal Ground for Speed Reference Input	For Speed Control Only

Use these signals when speed control (analog reference) mode is selected (Cn-2B is set to 0, 4, 7, 9, or 10).

For ordinary speed control, always wire the V-REF and SG terminals.

Motor speed is controlled in proportion to the input voltage between V-REF and SG.

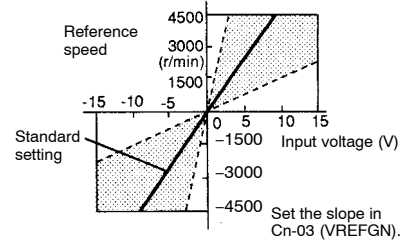

■ Standard Example:

Cn-03 = 500: This setting means that 6 V is 3000 min⁻¹

Examples:

+6 V input → 3000 min⁻¹ in forward direction

+1 V input → 500 min⁻¹ in forward direction

-3 V input → 1500 min⁻¹ in reverse direction

Parameter Cn-03 can be used to change the voltage input range.

■ Example of Input Circuit
(See the figure on the right)

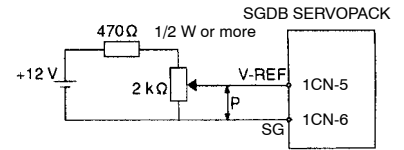

For noise control, always use twisted-pair cables.

Recommended Variable Resistor for Speed Setting:
Type 25HP-10B manufactured by Sakae Tsushin Kogyo Co., Ltd.

When position control is performed by a host controller such as a programmable controller, connect V-REF and SG to speed reference output terminals on the host controller. In this case, adjust Cn-03 according to output voltage specifications.

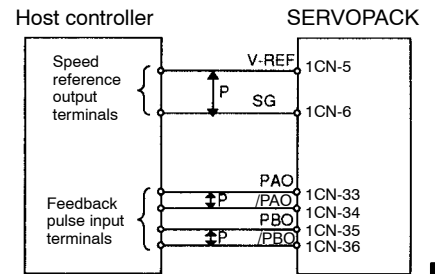

⇕P: Represents twisted-pair cables

The internal ±12 V power supply can be used.

+12V	1CN-23
-12V	1CN-24

Maximum output current: 30mA
Voltage: 12V±2V

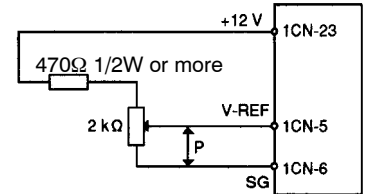

Set parameter Cn-2B to select one of the following control modes.

Cn-2B	Control Mode Selection	Factory Setting: 0	For Speed/Torque Control and Position Control
--------------	------------------------	--------------------	---

Cn-2B Setting	Control Method					
0	<p>Speed Control This is normal speed control.</p> <ul style="list-style-type: none"> Speed reference is input from V-REF (1CN-5). /P-CON (1CN-41) signal is used to switch between P control and PI control. <table border="1"> <tr> <td>1CN-41 is open</td> <td>PI control</td> </tr> <tr> <td>1CN-41 is at 0 V</td> <td>P control</td> </tr> </table>	1CN-41 is open	PI control	1CN-41 is at 0 V	P control	
1CN-41 is open	PI control					
1CN-41 is at 0 V	P control					

3

3

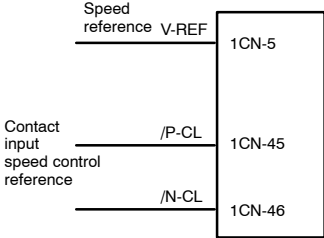
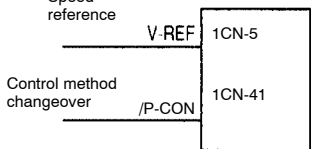
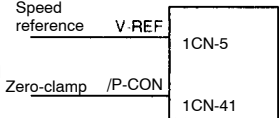
Cn-2B Setting	Control Method														
4	<p>Speed Control (Contact Reference) ↔ Speed Control (Analog Reference)</p> <p>This speed control allows switching between contact and analog references.</p> <ul style="list-style-type: none"> Analog reference is input from V-REF (1CN-5). /P-CL (1CN-45) and /N-CL (1CN-46) are used to switch between contact and analog references. Contact input speed is selected. <table border="1" data-bbox="587 566 1059 774"> <thead> <tr> <th>1CN-45</th> <th>1CN-46</th> <th></th> </tr> </thead> <tbody> <tr> <td>Open</td> <td>Open</td> <td>Analog reference</td> </tr> <tr> <td>Closed</td> <td>Open</td> <td rowspan="3">Contact reference</td> </tr> <tr> <td>Closed</td> <td>Closed</td> </tr> <tr> <td>Open</td> <td>Closed</td> </tr> </tbody> </table>	1CN-45	1CN-46		Open	Open	Analog reference	Closed	Open	Contact reference	Closed	Closed	Open	Closed	<p>SGDB SERVOPACK</p> 
1CN-45	1CN-46														
Open	Open	Analog reference													
Closed	Open	Contact reference													
Closed	Closed														
Open	Closed														
7, 9	<p>Position/Torque Control ↔ Speed Control</p> <p>This control mode can be switched between position/torque control and speed control.</p> <ul style="list-style-type: none"> Speed reference is input from V-REF (1CN-5). /P-CON (1CN-41) is used to switch the control mode between position/torque control and speed control. <table border="1" data-bbox="587 1044 1059 1168"> <tbody> <tr> <td>1CN-41 is open</td> <td>Position/Torque control</td> </tr> <tr> <td>1CN-41 is at 0 V</td> <td>Speed control</td> </tr> </tbody> </table>	1CN-41 is open	Position/Torque control	1CN-41 is at 0 V	Speed control	<p>SGDB SERVOPACK</p> 									
1CN-41 is open	Position/Torque control														
1CN-41 is at 0 V	Speed control														
10	<p>Zero-clamp Speed Control</p> <p>This speed control allows the zero-clamp function to be set when the motor stops.</p> <ul style="list-style-type: none"> Speed reference is input from V-REF (1CN-5). /P-CON (1CN-41) signal is used to turn the zero-clamp function ON or OFF. <table border="1" data-bbox="587 1417 1059 1540"> <tbody> <tr> <td>1CN-41 is open</td> <td>Turns zero-clamp function OFF</td> </tr> <tr> <td>1CN-41 is at 0 V</td> <td>Turns zero-clamp function ON</td> </tr> </tbody> </table>	1CN-41 is open	Turns zero-clamp function OFF	1CN-41 is at 0 V	Turns zero-clamp function ON	<p>SGDB SERVOPACK</p>  <p>Zero-clamp is performed when the following two conditions are met:</p> <p>Condition 1: /P-CON is turned ON.</p> <p>Condition 2: Motor speed drops below the preset value.</p> <p>Preset value: Cn-0F (ZCLVL)</p>									
1CN-41 is open	Turns zero-clamp function OFF														
1CN-41 is at 0 V	Turns zero-clamp function ON														

- Using /P-CON Signal:

→ Input /P-CON 1CN-41	Proportional Control, etc.	For Speed Control and Position Control
------------------------------	----------------------------	--

The function of input signal /P-CON changes with Cn-2B setting.

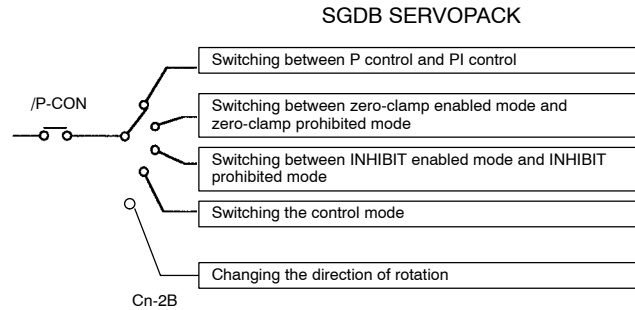

3

Cn-2B Setting	Meaning of /P-CON Signal
0, 1	Switching between proportional (P) control and proportional/integral (PI) control
2	(Not used)
3, 4, 5, 6	Changing the direction of rotation during contact input speed control
7, 8, 9	Switching the control mode
10	Switching between zero-clamp enabled and zero-clamp prohibited modes
11	Switching between INHIBIT enabled and INHIBIT prohibited modes

Email: service@repairtw.com

Adjust the speed reference gain using the following parameter.

Cn-03	VREFGN Speed Reference Gain	Unit: (min ⁻¹)/V	Setting Range: 10 to 2000	For Speed Control Only
--------------	-----------------------------	---------------------------------	------------------------------	------------------------



Zero-clamp function

This function is used for a system in which the host controller does not form a position loop. In this case, the stopping position may shift even if a speed reference is set to 0. If the zero-clamp function is turned ON, a position loop is internally formed so that the stopping position is firmly “clamped.”

3.2.2 Inputting Position Reference

Sets the voltage range for speed reference input V-REF (1CN-5). Sets this parameter according to the output form of the host controller or external circuit.

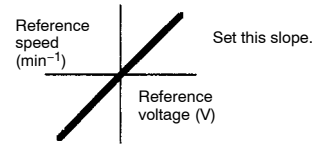

The factory setting is as follows:
Rated speed $\pm 1\%/6V$

Motor Series	Factory Setting
SGMG (1500 min ⁻¹)	250
SGMG (1000 min ⁻¹)	167
SGMD	333
SGMS, SGM, SGMP	500

3

3.2.2 Inputting Position Reference

Input a position reference by using the following input signal “reference pulse input.” Since there are several specifications for input signal, select reference input for the system to be created.

To use position control, set the following constant.

Cn-2B	Control Mode Selection	Factory setting: 0	For Speed / Torque Control and Position Control
--------------	------------------------	--------------------	---

Note Speed / Torque Control is selected at factory setting.

Cn-2B Setting	Control Mode
1	Position Control

■ Move Reference by Pulse Input

Inputs a move reference by pulse input.

Position reference can correspond to the following three types of output form:

- Line driver output
- +12V Open collector output
- +5V Open collector output

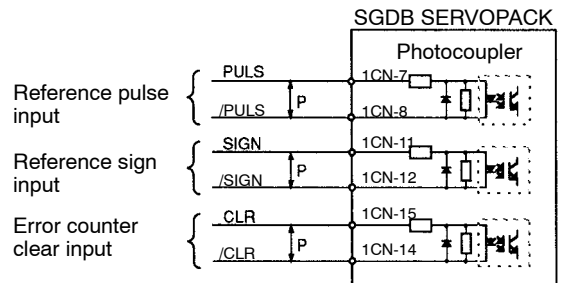

↑P: Represents twisted-pair cables

Connection Example 1: Line Driver Output

Line Driver Used:

SN75174 manufactured by Texas Instruments Inc., or MC3487 or equivalent.

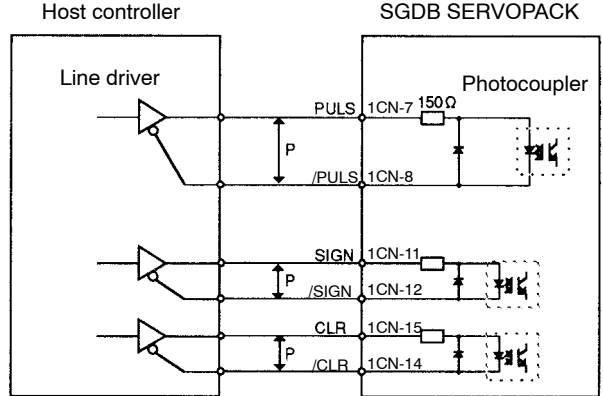

Connection Example 2: Open Collector Output

Sets the value of limiting resistor R1 so that input current i falls within the following range:

Input Current i : 7 to 15 mA

Examples:

- When V_{cc} is 12 V, $R1 = 1\text{ k}\Omega$
- When V_{cc} is 5 V, $R1 = 180\ \Omega$

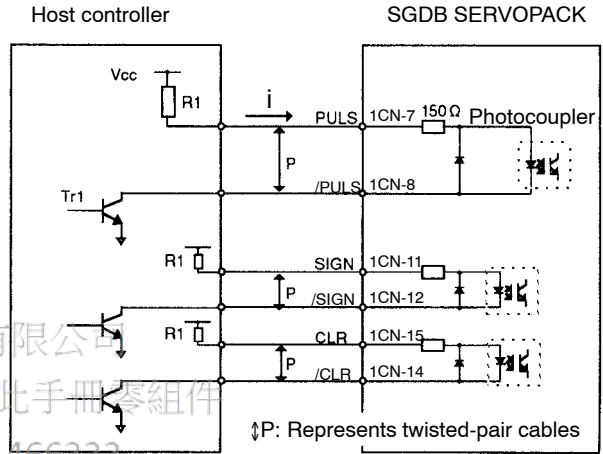

Note The signal logic for open collector output is as follows.

When Tr1 is ON	Equivalent to high level input
When Tr1 is OFF	Equivalent to low level input

The power supply inside the SERVOPACK can be used.

If this power supply is used, it will not be isolated from 0 V in the SERVOPACK.

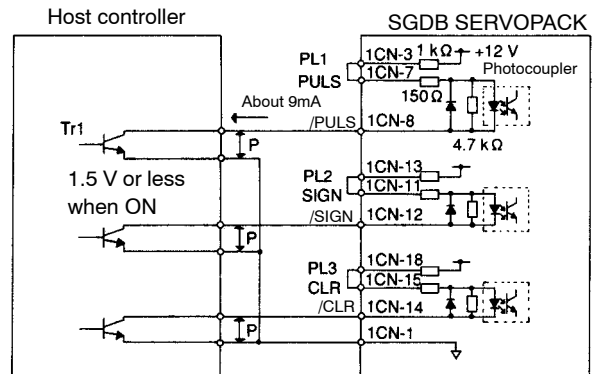

■ Selecting the Reference Pulse Form

Use the following memory switch to select the reference pulse form to be used:

→ Input PULS	1CN-7	Reference Pulse Input	For Position Control Only
→ Input /PULS	1CN-8	Reference Pulse Input	For Position Control Only
→ Input SIGN	1CN-11	Reference Sign Input	For Position Control Only
→ Input /SIGN	1CN-12	Reference Sign Input	For Position Control Only

The motor only rotates at an angle proportional to the input pulse.

Cn-02 Bit 3	Reference Pulse Form Selection	Factory Setting: 0	For Position Control Only
Cn-02 Bit 4	Reference Pulse Form Selection	Factory Setting: 0	For Position Control Only
Cn-02 Bit 5	Reference Pulse Form Selection	Factory Setting: 0	For Position Control Only

Sets the form of a reference pulse that is external-ly output to the SERVOPACK.

Sets the pulse form according to the host controller specifications.

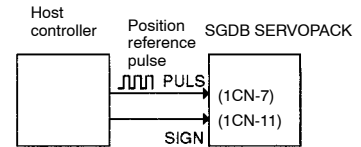

Set also the input pulse logic in bit D of Cn-02.

Bit D	Cn-02			Input Pulse Multiplier	Reference Pulse Form	Motor Forward Run Reference	Motor Reverse Run Reference
	Bit 5	Bit 4	Bit 3				
0 (Positive logic setting)	0	0	0	/	Sign + pulse train	PULS (1CN-7) SIGN (1CN-11)	PULS (1CN-7) SIGN (1CN-11)
	0	1	0	×1	Two-phase pulse train with 90° phase difference	PULS (1CN-7) SIGN (1CN-11)	PULS (1CN-7) SIGN (1CN-11)
	0	1	1	×2			
	1	0	0	×4			
	0	0	1	/	CW pulse + CCW pulse	PULS (1CN-7) SIGN (1CN-11)	PULS (1CN-7) SIGN (1CN-11)

3

上正科技有限公司
購買、維修 此手冊零組件
電話：037-466333

Bit D	Cn-02			Input Pulse Multiplier	Reference Pulse Form	Motor Forward Run Reference	Motor Reverse Run Reference
	Bit 5	Bit 4	Bit 3				
1 (Negative logic setting)	0	0	0	/	Sign + pulse train		
	0	1	0	×1	Two-phase pulse train with 90° phase difference		
	0	1	1	×2			
	1	0	0	×4			
	0	0	1	/	CW pulse + CCW pulse		

Input Pulse Multiply Function:

When the reference form is two-phase pulse train with 90° phase difference, the input pulse multiply function can be used.

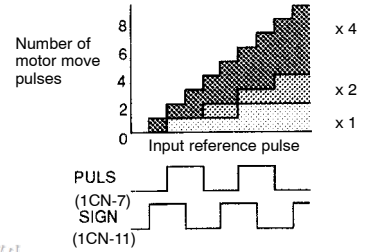

The electronic gear function can also be used to convert input pulses.

上正科技有限公司

購買、維修 此手冊電組件

電話： 037-466333

Email: service@repairtw.com

Line id: @zzzz

Example of I/O Signal Generation Timing

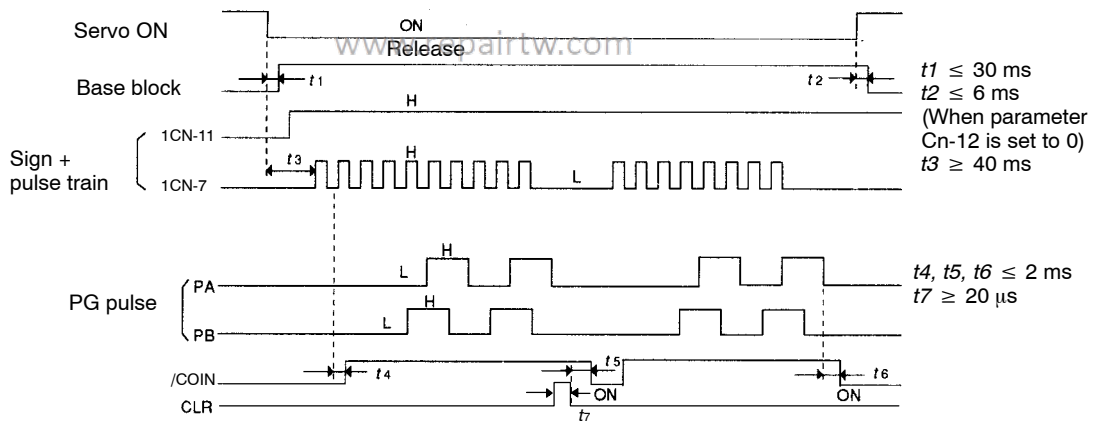

Note The interval from the time the servo ON signal is turned ON until a reference pulse is input must be at least 40 ms. Otherwise, the reference pulse may not be input. The error counter clear (CLR) signal must be ON for at least 20 μs. Otherwise, it becomes invalid.

Allowable Voltage Level and Timing for Reference Pulse Input

Reference Pulse Form	Electrical Specifications	Remarks
Sign + pulse train input (SIGN + PULS signal) Maximum reference frequency: 450 kpps	<p> $t_1, t_2 \leq 0.1 \mu s$ $r \geq 1.1 \mu s$ $t_3, t_7 \leq 0.1 \mu s$ $t_4, t_5, t_6 > 3 \mu s$ </p>	The signs for each reference pulse are as follows: ⊕: High level ⊖: Low level
90° different two-phase pulse train (phase A + phase B) Maximum reference frequency: x 1 multiplier: 450 kpps x 2 multiplier: 400 kpps x 4 multiplier: 200 kpps	<p> $t_1, t_2 \leq 0.1 \mu s$ $r \geq 1.1 \mu s$ $\frac{r}{T} \times 100 \leq 50\%$ </p>	Parameter Cn-02 (bits 3, 4 and 5) is used to switch the input pulse multiplier mode.
CCW pulse + CW pulse Maximum reference frequency: 450 kpps	<p> $t_1, t_2 \leq 0.1 \mu s$ $r \geq 1.1 \mu s$ $t_3 > 3 \mu s$ $\frac{r}{T} \times 100 \leq 50\%$ </p>	

3

上正科技有限公司
購買、維修 此手冊零組件

電話： 037-466333

■ Cleaning the Error Counter

Email: service@repairtw.com

The following describes how to clear the error counter.

Line id: @zzzz

→ Input CLR 1CN-15	Error Counter Clear Input	For Position Control Only
→ Input /CLR 1CN-14	Error Counter Clear Input	For Position Control Only

Setting the CLR signal to high level does the following:

- Sets the error counter inside the SERVOPACK to 0.
- Prohibits position loop control.

Use this signal to clear the error counter from the host controller.

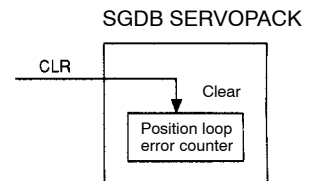

Bit A of memory switch Cn-02 can be set so that the error counter is cleared only once when the leading edge of an input pulse rises.

Cn-02 Bit A	Error Counter Clear Signal Selection	Factory Setting: 0	For Position Control Only
--------------------	--------------------------------------	--------------------	---------------------------

Selects the pulse form of error counter clear signal CLR (1CN-15).

Setting	Meaning	
0	Clears the error counter when the CLR signal is set at high level. Error pulses do not accumulate while the signal remains at high level.	
1	Clears the error counter only once when the rising edge of the CLR signal rises.	

3.2.3 Using Encoder Outputs

Encoder output signals **divided** inside the SERVOPACK can be output externally. These signals can be used to form a position control loop in the host controller.

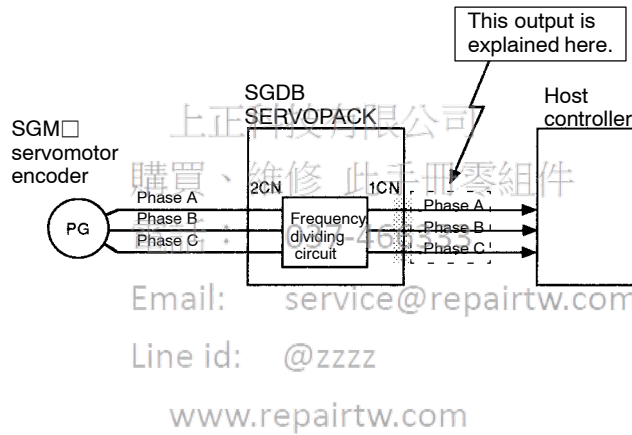

Divided (or dividing)

“Dividing” means converting an input pulse train from the encoder mounted on the motor according to the preset pulse density and outputting the converted pulse. The unit is pulses per revolution.

The output circuit is for line driver output. Connect each signal line according to the following circuit diagram.

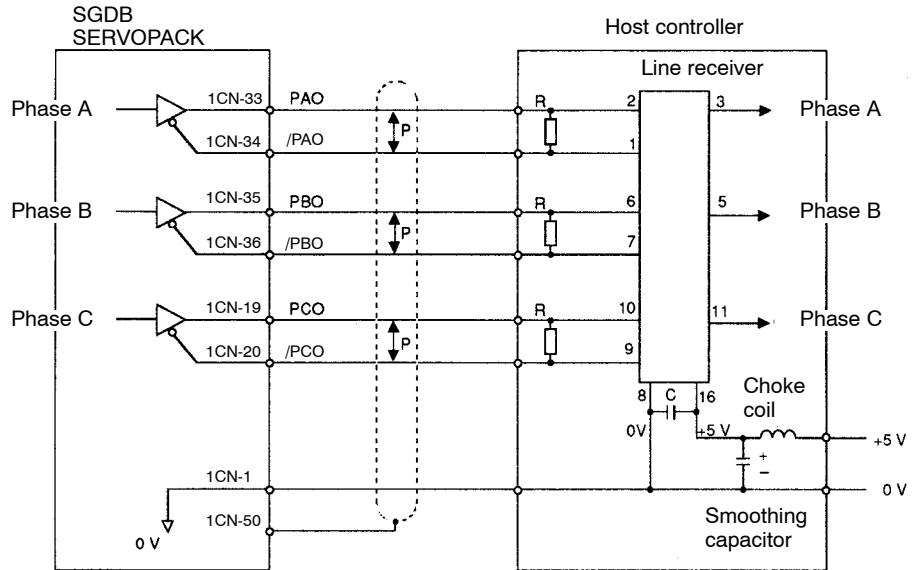

‡P: Represents twisted-pair cables

Line receiver used: SN75175 manufactured by Texas Instruments Inc. or MC3486 (or equivalent)

R (termination resistor): 220 to 470 Ω

C (decoupling capacitor): 0.1 μF

■ I/O Signals

I/O signals are described below.

Output →	PAO 1CN-33	Encoder Output Phase-A	For Speed/Torque Control and Position Control
Output →	/PAO 1CN-34	Encoder Output Phase-/A	For Speed/Torque Control and Position Control
Output →	PBO 1CN-35	Encoder Output Phase-B	For Speed/Torque Control and Position Control
Output →	/PBO 1CN-36	Encoder Output Phase-/B	For Speed/Torque Control and Position Control
Output →	PCO 1CN-19	Encoder Output Phase-C	For Speed/Torque Control and Position Control
Output →	/PCO 1CN-20	Encoder Output Phase-/C	For Speed/Torque Control and Position Control

Divided encoder signals are output.

Always connect these signal terminals when a position loop is formed in the host controller to perform position control.

Set a dividing ratio in the following parameter.

Dividing ratio setting	Cn-0A PGRAT
-------------------------------	-------------

The dividing ratio setting is not relevant to the gear ratio setting (Cn-24, 25) for the electronic gear function of the SERVOPACK when used for position control.

Output Phase Form

Incremental Encoder

Forward rotation

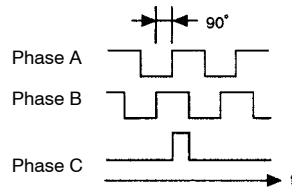

Reverse rotation

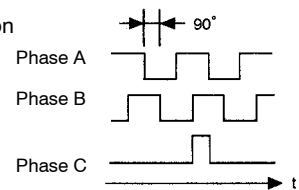

Absolute Encoder

Forward rotation

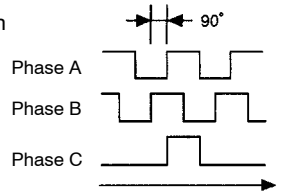

Reverse rotation

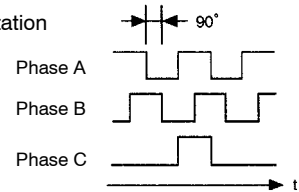

3

→ Input SEN 1CN-4	SEN Signal Input	For Speed/Torque Control Only
→ Input SG 1CN-2	Signal Ground	For Speed/Torque Control Only
Output → PSO 1CN-48	Encoder Output Phase-S	For Speed/Torque Control and Position Control
Output → /PSO 1CN-49	Encoder Output Phase-/S	For Speed/Torque Control and Position Control
→ Input BAT 1CN-21	Battery (+)	For Speed/Torque Control and Position Control
→ Input BAT0 1CN-22	Battery (-)	For Speed/Torque Control and Position Control

Use these signals (SEN to BAT0) for absolute encoders. For details, refer to *Section 3.8.5 Using an Absolute Encoder*.

Line id: @zzzz

Output → SG 1CN-1	Signal Ground	For Speed/Torque Control and Position Control
Output → FG 1CN-50	Frame Ground	For Speed/Torque Control and Position Control

SG: Connect to 0 V on the host controller.

FG: Connect to the cable shielded wire.

■ Selecting the Encoder Type

Use the following memory switch to specify the type of the encoder to be used.

Cn-01 Bit E	Encoder Type Selection	Factory Setting: 0	For Speed/Torque Control and Position Control
--------------------	------------------------	--------------------	---

Sets the encoder type according to the servomotor type as shown in the table.

After changing the memory switch setting, always turn the power OFF, then ON.

Motor Type encoder specifications	Number of Encoder Pulses Per Revolution (P/R)	Setting
2	Incremental encoder: 8192 pulses per revolution	0
3	Incremental encoder: 2048 pulses per revolution	
6	Incremental encoder: 4096 pulses per revolution	
W	Absolute encoder: 1024 pulses per revolution	1
S	Absolute encoder: 8192 pulses per revolution	

■ Setting the Pulse Dividing Ratio

Set the pulse dividing ratio in the following parameter.

Cn-0A	PGRAT Dividing Ratio Setting	Unit: P/R	Setting Range: 16 to 32768	For Speed/Torque Control and Position Control
--------------	------------------------------	-----------	----------------------------	---

Sets the number of output pulses for PG output signals (PAO, /PAO, PBO and /PBO).

Pulses from motor encoder (PG) are divided by the preset number of pulses before being output.

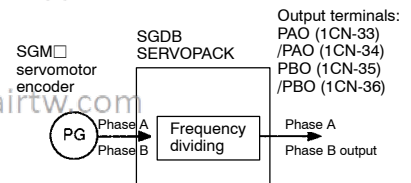

The number of output pulses per revolution is set in this parameter. Set this value according to the reference unit of the machine or controller to be used.

The setting range varies according to the encoder used.

Setting example:

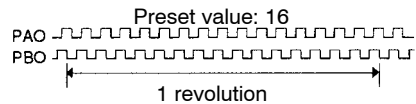

Motor Type encoder specifications	Number of Encoder Pulses Per Revolution	Setting Range
2	Incremental encoder: 8192 pulses per revolution	16 to 8192
3	Incremental encoder: 2048 pulses per revolution	16 to 2048
6	Incremental encoder: 4096 pulses per revolution	16 to 4096
W	Absolute encoder: 1024 pulses per revolution	16 to 1024
S	Absolute encoder: 8192 pulses per revolution	16 to 8192

After changing the parameter setting, always turn the power OFF, then ON.

3.2.4 Using Contact I/O Signals

■ Contact Input Signal Terminal Connections

These signals are used to control SGDB SERVOPACK operation. Connect these signal terminals as necessary.

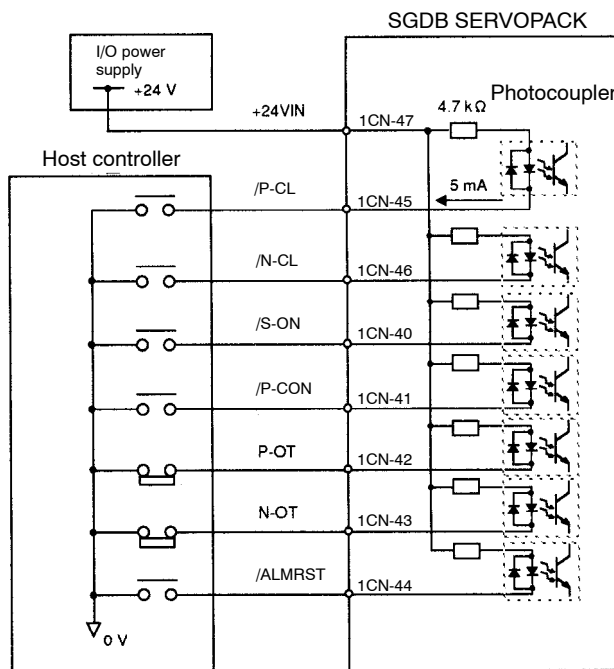

3

Note Provide an external I/O power supply separately. There are no power terminals available from the SGDB SERVOPACK outputs signals externally.

External Power Supply: 24 ± 1 VDC
50 mA or more

Yaskawa recommends that this external power supply be the same type as for the output circuit.

→ Input +24VIN 1CN-47	I/O Power Supply	For Speed/Torque Control and Position Control
-----------------------	------------------	---

This external power supply input terminal is common to the following contact input signals:

- Contact Input Signals:**
- /P-CL (1CN-45)
 - /N-CL (1CN-46)
 - /S-ON (1CN-40)
 - /P-CON (1CN-41)
 - P-OT (1CN-42)
 - N-OT (1CN-43)
 - /ALMRST (1CN-44)

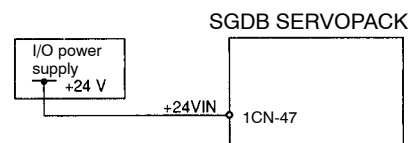

Connect an external I/O power supply.

■ Contact Output Signal Terminal Connections

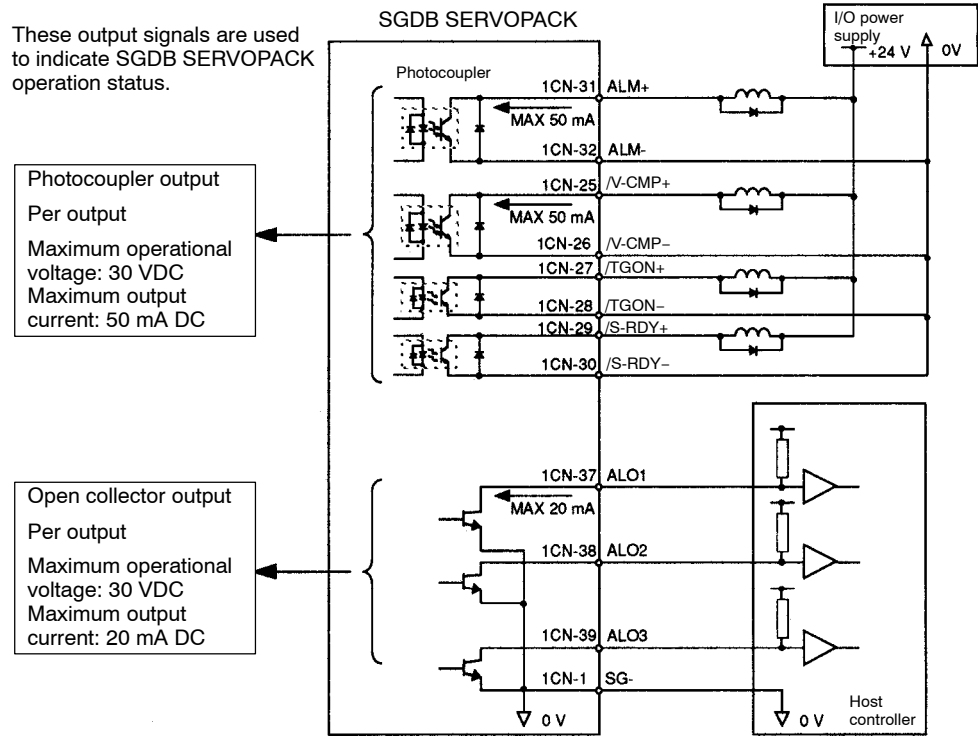

Note Provide an external I/O power supply separately. There are no power terminals to which the SGDB SERVOPACK outputs signals externally. Yaskawa recommends that this external power supply be the same type as for the input circuit.

電話： 037-466333

Email: service@repairtw.com

Line id: @zzzz

www.repairtw.com

3.2.5 Using Electronic Gear

The electronic gear function enables the motor travel distance per input reference pulse to be set to any value. It allows the host controller to perform control without having to consider the machine gear ratio and the number of encoder pulses.

When Electronic Gear Function is Not Used

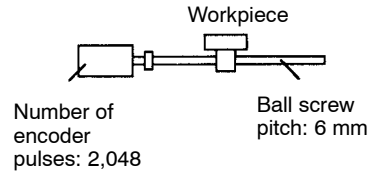

To move a workpiece 10 mm :

One revolution is equivalent to 6 mm, so
 $10 \div 6 = 1.6666$ (revolutions)
 2048 x 4 (pulses) is equivalent to one revolution, so
 $1.6666 \times 2,048 \times 4 = 13,653$ (pulses)
 A total of 13653 pulses must be input as a reference.

The host controller needs to make this calculation.

When Electronic Gear Function is Used

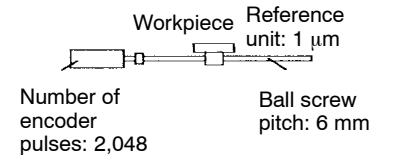

Machine conditions and reference unit must be defined for the electronic gear function beforehand.

To move a workpiece 10 mm:

Reference unit is 1 μm, so
 $10 \text{ mm} \div 1 \mu\text{m} = 10,000$ pulses



■ Setting the Electronic Gear

Calculate the electronic gear ratio (B/A) according to the procedure below and set the value in Cn-24 and Cn-25.

1. Check the machine specifications.

Items related to electronic gear:

- Gear ratio
- Ball screw pitch
- Pulley diameter

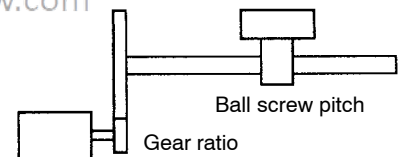

2. Check the number of encoder pulses for the SGM□ servomotor.

Motor Type encoder specifications	Encoder Type	Number of Encoder Pulses Per Revolution (P/R)
2	Incremental encoder	8192
3		2048
6		4096
W	Absolute encoder	1024
S		8192

Same as parameter Cn-11 settings.

- Determine the reference unit to be used.

Reference unit is the minimum unit of position data used for moving the load.
(Minimum unit of reference from host controller)

Examples:
0.01 mm, 0.001 mm, 0.1°, 0.01 inch

Reference input of one pulse moves the load by one reference unit.

Example: When reference unit is 1 μm
If a reference of 50,000 pulses is input, the load moves 50 mm (50,000 × 1 μm).

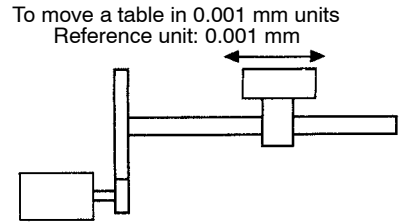

Determine the reference unit according to machine specifications and positioning accuracy.

- Determine the load travel distance per revolution of load shaft in reference units.

Load travel distance per revolution of load shaft (in reference units)

$$= \frac{\text{Load travel distance per revolution of load shaft (in unit of distance)}}{\text{Reference unit}}$$

Example: When ball screw pitch is 5 mm and reference unit is 0.001 mm
5/0.001 = 5,000 (reference units)

Ball Screw	Disc Table	Belt & Pulley
<p>Load shaft P: Pitch 1 revolution = $\frac{P}{\text{Reference unit}}$</p>	<p>Load shaft 1 revolution 360° Reference unit</p>	<p>Load shaft πD D: Pulley diameter 1 revolution πD = $\frac{\pi D}{\text{Reference unit}}$</p>

- Determine the electronic gear ratio $\left(\frac{B}{A}\right)$.

If the load shaft makes “n” revolutions when the motor shaft makes “m” revolutions, the gear ratio of motor shaft and load shaft is $\frac{n}{m}$.

Electronic gear ratio $\left(\frac{B}{A}\right) =$

$$\frac{\text{Number of encoder pulses} \times 4}{\text{Travel distance per revolution of load shaft (in reference units)}} \times \frac{m}{n}$$

NOTE Make sure that the electronic gear ratio meets the following condition:

$$0.01 \leq \text{Electronic gear ratio} \left(\frac{B}{A}\right) \leq 100$$

If the electronic gear ratio is outside this range, the SERVOPACK does not work properly. In this case, modify the load configuration or reference unit.

6. Set the electronic gear ratio in the parameters below.

Reduce the electronic gear ratio $\left(\frac{B}{A}\right)$ to their lowest terms so that both A and B are an integer smaller than 65535, then set A and B in the following parameters.

$\left(\frac{B}{A}\right)$	Cn-24	RATB	Electronic gear ratio (numerator)
	Cn-25	RATA	Electronic gear ratio (denominator)

This is all that is required to set the electronic gear.

Cn-24	RATB Electronic Gear Ratio (Numerator)	Unit: None	Setting Range: 1 to 65535	Factory Setting: 4	For Position Control Only
Cn-25	RATA Electronic Gear Ratio (Denominator)	Unit: None	Setting Range: 1 to 65535	Factory Setting: 1	For Position Control Only

3

Set the electronic gear ratio according to machine specifications.

$$\text{Electronic gear ratio } \left(\frac{B}{A}\right) = \frac{\text{Cn-24}}{\text{Cn-25}}$$

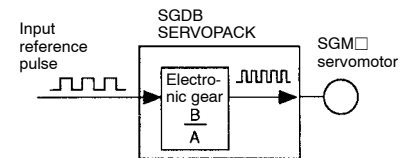

$$B = [(\text{Number of encoder pulses}) \times 4] \times [\text{Motor shaft rotating speed}]$$

$$A = [\text{Reference unit (load travel distance per revolution of load shaft)}] \times [\text{Load shaft rotating speed}]$$

Note that the parameter settings must meet the following condition:

$$0.01 \leq \left(\frac{B}{A}\right) \leq 100$$

www.repairtw.com

■ Examples of Setting an Electronic Gear Ratio for Different Load Mechanisms

Ball Screw

Reference unit: 0.001 mm

$$\text{Travel distance per revolution of load shaft} = \frac{6\text{mm}}{0.001\text{mm}} = 6000$$

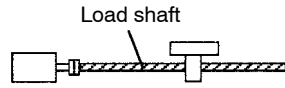

Incremental encoder:
2048 pulses per revolution

Ball screw pitch: 6 mm

$$\text{Electronic gear ratio } \left(\frac{B}{A}\right) = \frac{2048 \times 4 \times 1}{6000 \times 1} = \frac{Cn-24}{Cn-25}$$

Preset values	Cn-24	8192
	Cn-25	6000

Disc Table

Reference unit:
0.1°

Gear ratio:
3 : 1

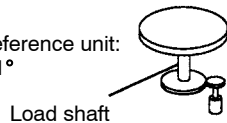

Incremental encoder:
2048 pulses per revolution

$$\text{Travel distance per revolution of load shaft} = \frac{360^\circ}{0.1^\circ} = 3600$$

$$\text{Electronic gear ratio } \left(\frac{B}{A}\right) = \frac{2048 \times 4 \times 3}{3600 \times 1} = \frac{Cn-24}{Cn-25}$$

Preset values	Cn-24	24576
	Cn-25	3600

Belt & Pulley

Reference unit: 0.0254 mm
Load shaft

$$\text{Travel distance per revolution of load shaft} = \frac{3.14 \times 100\text{mm}}{0.0254\text{mm}} = 12362$$

Gear ratio:
2.4 : 1

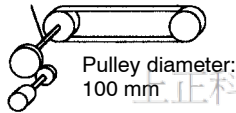

Pulley diameter:
100 mm

$$\text{Electronic gear ratio } \left(\frac{B}{A}\right) = \frac{1024 \times 4 \times 2.4}{12362 \times 1} = \frac{Cn-24}{Cn-25}$$

$$\text{Absolute encoder} = \frac{9830.4}{12362} = \frac{49152}{61810}$$

1024 pulses per revolution

Preset values	Cn-24	49152
	Cn-25	61810

■ Control Block Diagram for Position Control

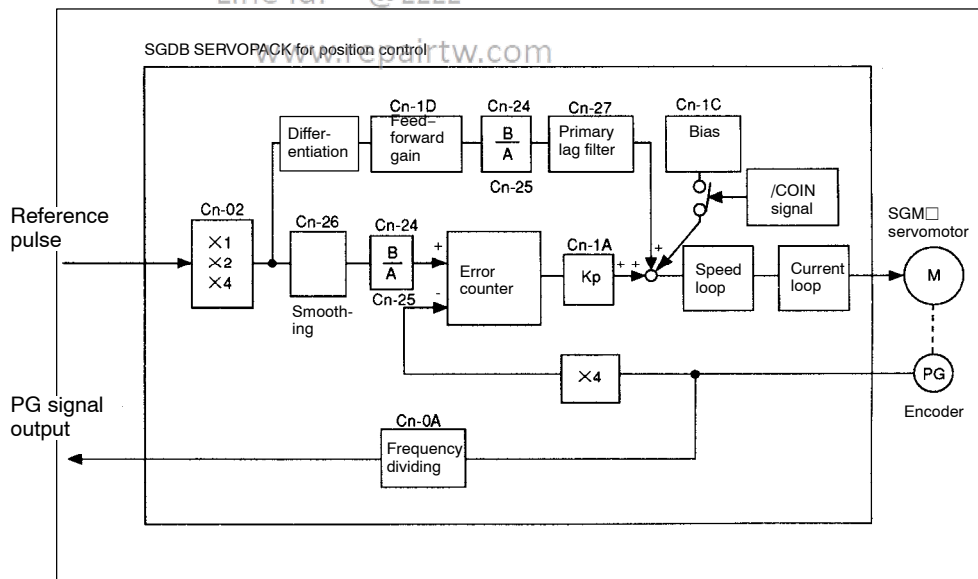

3.2.6 Using Contact Input Speed Control

The contact input speed control function provides easy-to-use speed control. It allows the user to initially set three different motor speeds in parameters, select one of the speeds externally by contact input and run the motor.

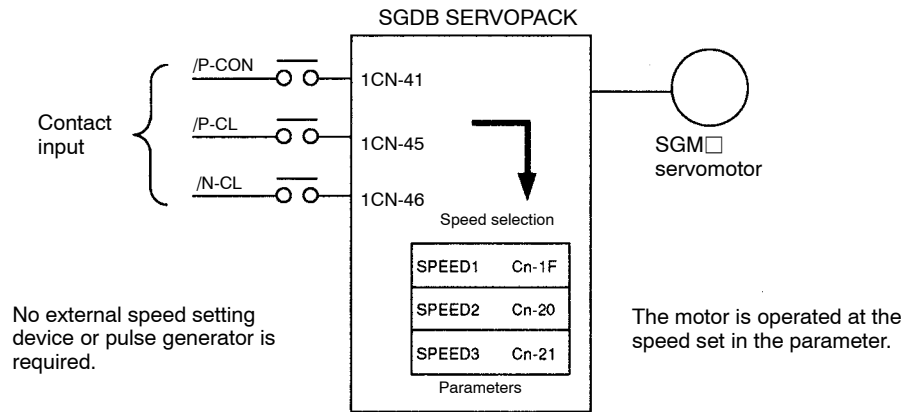

3

■ Using the Contact Input Speed Control Function

To use the contact input speed control function, perform Steps a) to c).

1. Set memory switch Cn-02 as follows.

Cn-2B	Control Mode Selection	Factory Setting: 0	For Speed/Torque Control and Position Control
--------------	------------------------	--------------------	---

Enables the contact input speed control function.

If the contact input speed control function is used, the contents of the input signals shown below will change.

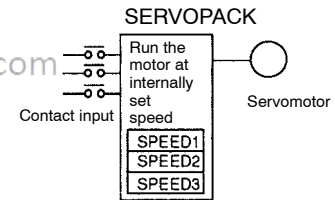

When this memory switch is reset, the meanings of the following signals will also change:

Monitor mode (Un-05) bit 7 and bit 8

Setting	Meaning	Input Signal																			
0, 1, 2, 7, 8, 9, 10, 11	Does not use the contact input speed control function.	/P-CON (1CN-41)	Used to switch between P control and PI control and to perform other functions.																		
		/P-CL (1CN-45)	Used for forward external current limit input																		
		/N-CL (1CN-46)	Used for reverse external current limit input																		
3, 4, 5, 6	<p>Uses the contact input speed control function.</p> <p>Note In the case of the position control type, the reference pulse inhibit function (INHIBIT) cannot be used.</p>	0: OFF, 1: ON																			
		<table border="1"> <thead> <tr> <th>/P-CON</th> <th>/P-CL</th> <th>/N-CL</th> <th>Speed Setting</th> </tr> </thead> <tbody> <tr> <td>Direction of rotation</td> <td>0</td> <td>0</td> <td>0 reference and so on</td> </tr> <tr> <td rowspan="3">0: Forward 1: Reverse</td> <td>0</td> <td>1</td> <td>Cn-1F, SPEED1</td> </tr> <tr> <td>1</td> <td>1</td> <td>Cn-20, SPEED2</td> </tr> <tr> <td>1</td> <td>0</td> <td>Cn-21, SPEED3</td> </tr> </tbody> </table>		/P-CON	/P-CL	/N-CL	Speed Setting	Direction of rotation	0	0	0 reference and so on	0: Forward 1: Reverse	0	1	Cn-1F, SPEED1	1	1	Cn-20, SPEED2	1	0	Cn-21, SPEED3
/P-CON	/P-CL	/N-CL	Speed Setting																		
Direction of rotation	0	0	0 reference and so on																		
0: Forward 1: Reverse	0	1	Cn-1F, SPEED1																		
	1	1	Cn-20, SPEED2																		
	1	0	Cn-21, SPEED3																		

2. Set three motor speeds in the following parameters.

Parameter	Description	Unit	Setting Range	Factory Setting	Notes
Cn-1F	SPEED1 1st Speed (Contact Input Speed Control)	min ⁻¹	0 to 10000	100	For Speed Control only
Cn-20	SPEED2 2nd Speed (Contact Input Speed Control)	min ⁻¹	0 to 10000	200	For Speed Control only
Cn-21	SPEED3 3rd Speed (Contact Input Speed Control)	min ⁻¹	0 to 10000	300	For Speed Control only

Use these parameters to set motor speeds when the contact input speed control function is used.

If a value higher than the maximum speed is set, the maximum speed value is used.

Speed selection input signals /P-CL (1CN-45) and /N-CL (1CN-46), and rotation direction selection signal /P-CON (1CN-41) enable the motor to run at the preset speeds.

Contact input speed control

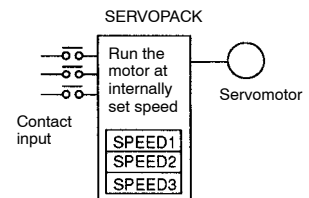

3. Set the soft start time.

Parameter	Description	Unit	Setting Range	Factory Setting	Notes
Cn-07	SFSACC Soft Start Time (Acceleration)	ms	0 to 10000	0	For Speed Control only
Cn-23	SFSDEC Soft Start Time (Deceleration)	ms	0 to 10000	0	For Speed Control only

In the SERVOPACK, a speed reference is multiplied by the preset acceleration or deceleration value to provide speed control.

When a progressive speed reference is input or contact input speed control is used, smooth speed control can be performed. (For normal speed control, set "0" in each parameter.)

Set the following value in each parameter.

- Cn-07: Time interval from the time the motor starts until it reaches the maximum speed
- Cn-23: Time interval from the time the motor is running at the maximum speed until it stops

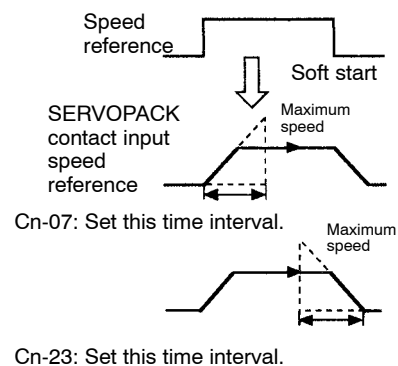

■ Operating by Contact Input Speed Control Function

Contact input speed control performs the following operation.

The following input signals are used to start and stop the motor.

→ Input /P-CL 1CN-45	Speed Selection 1 (Forward External Torque Limit Input)	For Speed/Torque Control and Position Control
→ Input /N-CL 1CN-46	Speed Selection 2 (Reverse External Torque Limit Input)	For Speed/Torque Control and Position Control

When Contact Input Speed Control is used:

Contact Signal			Parameter	Selected Speed
/P-CON	/P-CL	/N-CL	Cn-2B	
----	0	0	3	Stopped by internal speed reference 0
			4	Analog speed reference input (V-REF)
			5	Pulse reference input (position control)
			6	Analog torque reference input (torque control)
Direction of rotation 0: Forward rotation 1: Reverse rotation	0	1	Common to 3, 4, 5 and 6	SPEED 1 (Cn-1F)
	1	1		SPEED 2 (Cn-20)
	1	0		SPEED 3 (Cn-21)

----: Not used

Modes Other Than Contact Input Speed Control

Input signals are used as external torque limit input.

Input signal /P-CON is used to specify the direction of motor rotation.

→ Input /P-CON 1CN-41	Proportional Control, etc.	For Speed/Torque Control and Position Control
-----------------------	----------------------------	---

When Contact Input Speed Control is used:

Use input signal /P-CON to specify the direction of motor rotation.

/P-CON	Meaning
1	Reverse rotation
0	Forward rotation

0: OFF (high level), 1: ON (low level)

Modes Other Than Contact Input Speed Control

/P-CON signal is used for proportional control, zero-clamp and torque/speed control changeover.

The figure below illustrates an example of operation in contact input speed control mode. Using the soft start function reduces physical shock at speed changeover.

When Contact Input Speed Control is Used

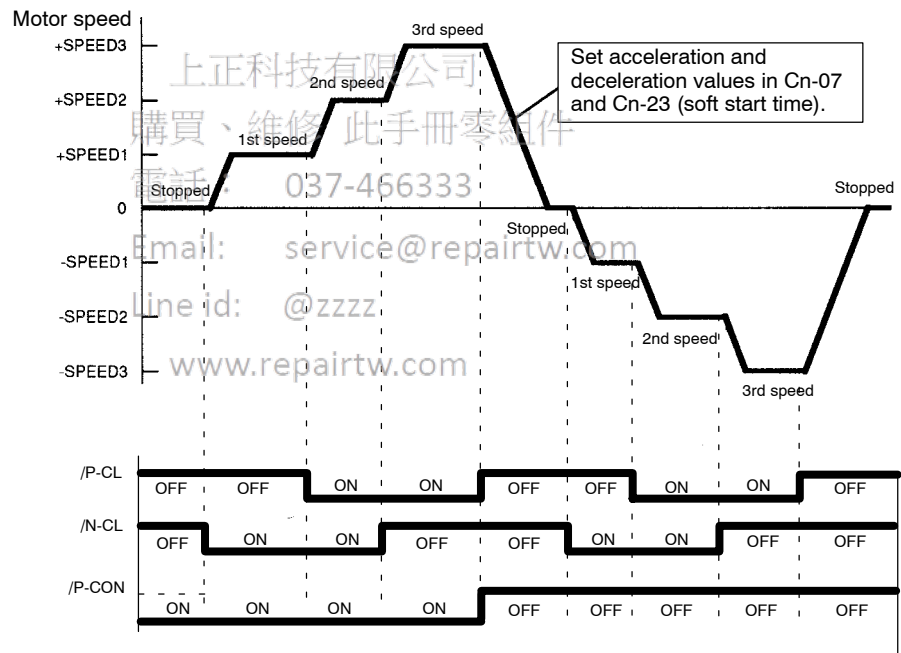

Note When the parameter Cn-2B is set to 5, the soft start function works only in contact input speed control mode. The soft start function is not available when pulse reference input is used.

If contact input speed control mode is switched to pulse reference input mode when the motor is running at the 1st, 2nd or 3rd speed, the SERVOPACK does not receive a pulse reference until positioning complete signal /COIN is output.

Always start outputting a pulse reference from the host controller after a positioning complete signal is output from the SERVOPACK.

Signal Generation Timing for Position Control Type

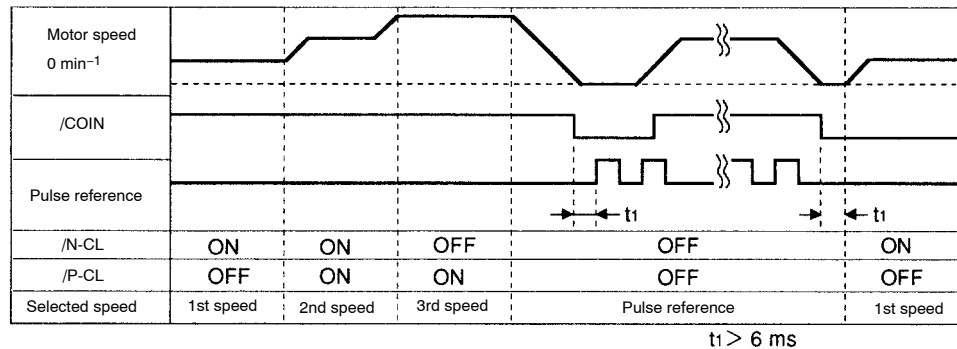

The above figure illustrates signal generation timing when the soft start function is used.

The value of t_1 is not influenced by use of the soft start function.

A maximum of 6 ms delay occurs when /P-CL or /N-CL signal is read.

士正科技有限公司

購買、維修 此手冊零組件

電話： 037-466333

Email: service@repairtw.com

Line id: @zzzz

3.2.7 Using Torque Control

The SERVOPACK can provide the following torque control:

- Torque restriction
 - Level 1: To restrict the maximum output torque to protect the machine or workpiece
 - Level 2: To restrict torque after the motor moves the machine to a specified position
- Torque control
 - Level 3: To always control output torque, not speed
 - Level 4: To switch between torque control and other control

This section describes how to use levels 3 and 4 of the torque control function.

■ Selecting Torque Control

Use the following parameter to select level 3 or level 4 torque control.

Cn-2B	Control Mode Selection	Factory Setting: 0	For Speed/Torque Control and position Control
--------------	------------------------	--------------------	---

This is dedicated torque control.

A motor torque reference value is externally input into the SERVOPACK to control torque.

Examples of Use: Tension control
Pressure control

3

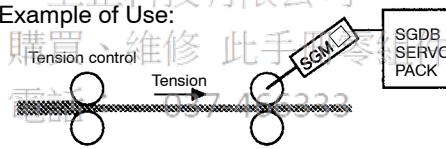
Cn-2B	Control Mode				
2	<p>Torque Control</p> <p>This is a dedicated torque control mode.</p> <ul style="list-style-type: none"> A torque reference is input from T-REF (1CN-9). /P-CON is not used. Speed reference input V-REF (1CN-5) can be used as speed limit when bit 2 of Cn-02 is set to 1. Parameter Cn-14 can be used for maximum speed control. <p>Example of Use:</p> 				
9	<p>Torque Control ↔ Speed Control (Analog Reference)</p> <p>Torque control and speed control can be switched.</p> <ul style="list-style-type: none"> A speed reference or speed limit value is input from V-REF (1CN-5). T-REF (1CN-9) inputs a torque reference, torque feed-forward reference or torque limit value depending on the control mode used. /P-CON (1CN-41) is used to switch between torque control and speed control. <table border="1" data-bbox="619 1815 976 1938"> <tr> <td>When 1CN-41 is open</td> <td>Torque control</td> </tr> <tr> <td>When 1CN-41 is at 0 V</td> <td>Speed control</td> </tr> </table>	When 1CN-41 is open	Torque control	When 1CN-41 is at 0 V	Speed control
When 1CN-41 is open	Torque control				
When 1CN-41 is at 0 V	Speed control				

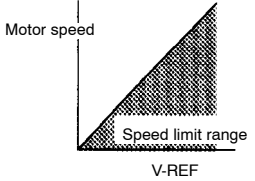
Cn-2B	Control Mode															
9	<p>In the Torque Control mode (/P-CON is OFF):</p> <ul style="list-style-type: none"> • T-REF reference controls torque. • V-REF can be used to limit motor speed. (when bit 2 of Cn-02 is 1) V-REF voltage (+) limits motor speed during forward or reverse rotation. • Parameter Cn-14 can be used to limit the maximum motor speed. <p>Principle of Speed Restriction:</p> <p>When the speed exceeds the speed limit, negative feedback of torque proportional to the difference between the current speed and the limit speed is performed to return the speed to within the normal speed range. Therefore, the actual motor speed limit value has a certain range depending on the load conditions.</p> <div style="text-align: right;">  </div>															
	<p>In the Speed Control mode (/P-CON is ON): Values set in bit 9 of parameter Cn-02 and bit 8 of Cn-02 determine the following:</p>															
<table border="1"> <thead> <tr> <th colspan="2">Parameter</th> <th rowspan="2">Speed Reference Input (V-REF) (1CN-5, 6)</th> <th rowspan="2">Torque Input (T-REF) (1CN-9, 10)</th> <th rowspan="2">Remarks</th> </tr> <tr> <th>Cn-02</th> <th>Cn-02</th> </tr> </thead> <tbody> <tr> <td>Bit 9</td> <td>Bit 8</td> <td></td> <td></td> <td></td> </tr> </tbody> </table>		Parameter		Speed Reference Input (V-REF) (1CN-5, 6)	Torque Input (T-REF) (1CN-9, 10)	Remarks	Cn-02	Cn-02	Bit 9	Bit 8						
Parameter		Speed Reference Input (V-REF) (1CN-5, 6)	Torque Input (T-REF) (1CN-9, 10)				Remarks									
Cn-02	Cn-02															
Bit 9	Bit 8															
0	0	Speed control		Any value can be set in bit 8 of Cn-02 (0 and 1 have the same effect). For details of speed control with torque feed-forward, refer to <i>Section 3.2.8 Using Torque Feed-forward Function</i> .												
1	---	Speed reference	Torque feed-forward													
0	1	Speed control with torque limit by analog voltage reference		For details of speed control with torque limit by analog voltage reference, refer to <i>Section 3.2.9 Using Torque Restriction by Analog Voltage Reference</i> .												
		Speed reference	Torque limit value													

3

Cn-2B	Control Mode															
8	<p><u>Position Control ↔ Torque Control</u></p> <p>This mode allows switching between position control and torque control.</p> <ul style="list-style-type: none"> /P-CON (1CN-41) is used to switch the control mode between position control and torque control. <table border="1"> <tr> <td>When 1CN-41 is open</td> <td>Position control</td> </tr> <tr> <td>When 1CN-41 is at 0 V</td> <td>Torque control</td> </tr> </table>	When 1CN-41 is open	Position control	When 1CN-41 is at 0 V	Torque control											
When 1CN-41 is open	Position control															
When 1CN-41 is at 0 V	Torque control															
6	<p><u>Speed Control (Contact Reference) ↔ Torque Control</u></p> <p>This mode allows switching between speed control (contact reference) and torque control.</p> <ul style="list-style-type: none"> /P-CL (1CN-45) and /N-CL (1CN-46) are used to switch the control mode between speed control (contact reference) and torque control. <table border="1"> <tr> <th>1CN-45</th> <th>1CN-46</th> <th></th> </tr> <tr> <td>Open</td> <td>Open</td> <td>Torque control</td> </tr> <tr> <td>Open</td> <td>Closed</td> <td>Speed control</td> </tr> <tr> <td>Closed</td> <td>Closed</td> <td>Speed control (contact reference)</td> </tr> <tr> <td>Closed</td> <td>Open</td> <td></td> </tr> </table>	1CN-45	1CN-46		Open	Open	Torque control	Open	Closed	Speed control	Closed	Closed	Speed control (contact reference)	Closed	Open	
1CN-45	1CN-46															
Open	Open	Torque control														
Open	Closed	Speed control														
Closed	Closed	Speed control (contact reference)														
Closed	Open															

■ Input Signals

The following input signals perform torque control.

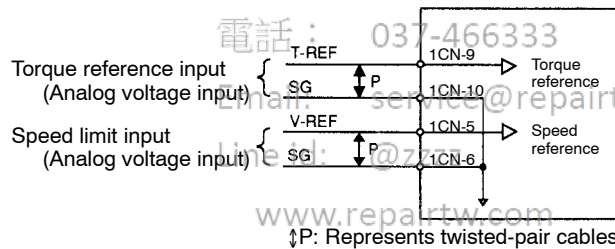

→ Input T-REF 1CN-9	Torque Reference Input	For Speed/Torque Control Only
→ Input SG 1CN-10	Signal Ground for Torque Reference Input	For Speed/Torque Control Only

These signals are used when torque control is selected.

Motor torque is controlled so that it is proportional to the input voltage between T-REF and SG.

Standard Setting

Cn-13 = 30: This setting means that 3V is equivalent to rated torque.

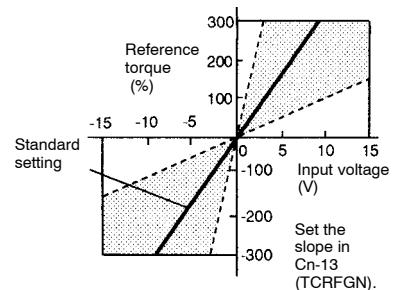

- Examples: +3 V input → Rated torque in forward direction
 +9 V input → 300% of rated torque in forward direction
 -0.3 V input → 10% of rated torque in reverse direction

Parameter Cn-13 can be used to change the voltage input range.

Example of Input Circuit:
 See the figure on the right.

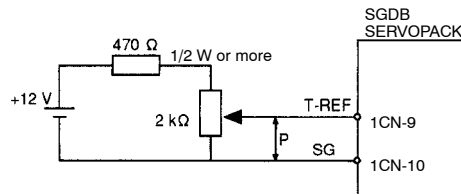

- For noise control, always use twisted-pair cables.

- Example of Variable Resistor for Speed Setting:
 Type 25HP-10B manufactured by Sakae Tsushin Kogyo Co., Ltd.

→ Input V-REF	1CN-5	Speed Reference Input (or Speed Limit Input)	For Speed/Torque Control Only
→ Input SG	1CN-6	Signal Ground for Speed Reference Input	For Speed/Torque Control Only

3

These signals are used when speed control is selected.

For normal speed control, always connect these signal terminals.

Motor speed is controlled so that it is proportional to the input voltage between V-REF and SG.

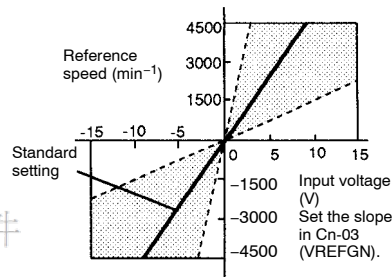

Standard Example
 Cn-03 = 500: This setting means that 6 V is equivalent to 3000 min⁻¹.

- Examples: +6 V input → 3000 min⁻¹ in forward direction
 +1 V input → 500 min⁻¹ in forward direction
 -3 V input → 1500 min⁻¹ in reverse direction

Parameter Cn-03 can be used to change the voltage input range. (This is also applicable to speed restriction.)

Example of Input Circuit:
 See the figure on the right.

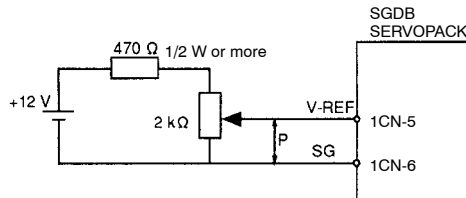

- For noise control, always use twisted-pair cables.

- Example of Variable Resistor for Speed Setting:
 Type 25HP-10B manufactured by Sakae Tsushin Kogyo Co., Ltd.

- Using /P-CON Signal

→ Input /P-CON 1CN-41	Proportional Control, etc.	For Speed/Torque Control and Position Control
-----------------------	----------------------------	---

- The function of this input signal varies according to the Cn-2B setting.

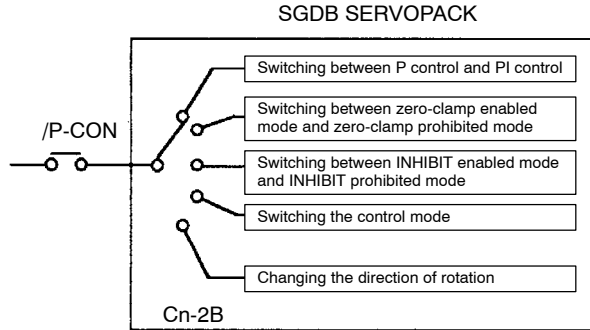

Cn-2B Setting	Meaning of /P-CON Signal
0, 1	Switching between P control and PI control.
2	(Not used)
3, 4, 5, 6	Switching the direction of rotation when contact input speed control mode is selected.
7, 8, 9	Switching the control mode.
10	Switching between zero-clamp enabled and zero-clamp prohibited modes.
11	Switching between INHIBIT enabled and INHIBIT prohibited modes.

■ Parameters

Set the following parameters for torque control according to the servo system used.

Cn-13	TCRFGN Torque Reference Gain	Unit: 0.1 V/Rated Torque	Setting Range: 10 to 100	Factory Setting: 30	For Speed/Torque Control Only
--------------	---------------------------------	-----------------------------	-----------------------------	------------------------	-------------------------------

Sets the voltage range of torque reference input T-REF (1CN-9) according to the output form of the host controller or external circuit.

The factory setting is 30, so the rated torque is 3 V (30 x 0.1).

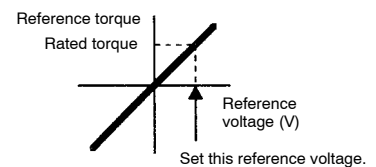

Cn-14	TCRLMT Speed Limit for Torque Control	Unit: min ⁻¹	Setting Range: 0 to 10000	Factory Setting: 10000	For Speed/Torque Control Only
--------------	--	----------------------------	---------------------------	------------------------	-------------------------------

Sets a motor speed limit value in torque control mode.

This parameter is used to prevent machine over-speed during torque control.

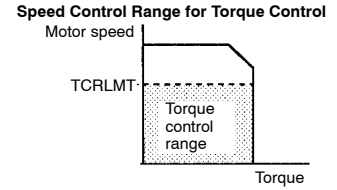

Cn-03	VREFGN Speed Reference Gain	Unit: (min ⁻¹)/V	Setting Range: 0 to 2000		For Speed/Torque Control Only
--------------	--------------------------------	---------------------------------	--------------------------	--	-------------------------------

Sets the voltage range of speed reference input V-REF (1CN-5) according to the output form of the⁻¹ host controller or external circuit.

The factory setting is rated speed $\pm 1\%/6V$.

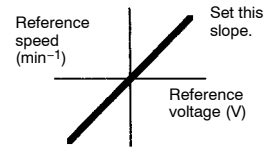

Motor Series	Factory Setting
SGMG (1500 min ⁻¹)	250
SGMG (1000 min ⁻¹)	167
SGMD	333
SGMS, SGM, SGMP	500

購買、維修 此手冊零組件

電話： 037-466333

Email: service@repairtw.com

Line id: @zzzz

www.repairtw.com

3.2.8 Using Torque Feed-forward Function

For speed control (analog reference) only.

The torque feed-forward function reduces positioning time. It differentiates a speed reference at the host controller (prepared by the customer) to generate a torque feed-forward reference, then sends this torque feed-forward reference and the speed reference to the SERVOPACK.

Too high a torque feed-forward value will result in overshoot or undershoot. To prevent this, set the optimum value while observing system response.

Connect a speed reference signal line and torque feed-forward reference signal line from the host controller to V-REF (1CN-5, 1CN-6) and T-REF (1CN-9, 1CN-10), respectively.

3

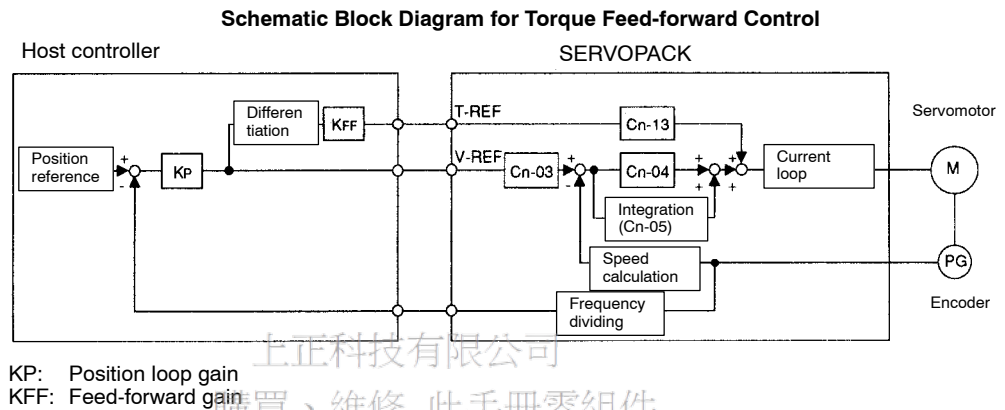

How to Use Torque Feed-forward Function

To use the torque feed-forward function, set the following memory switch to 1.

Cn-02 Bit 9	Selection of Torque Feed-forward Function	Factory Setting: 0	For Speed/Torque Control Only
--------------------	---	--------------------	-------------------------------

Enables the torque feed-forward function.

To use the torque feed-forward function, input a speed reference to the V-REF terminal and a torque feed-forward reference to the T-REF terminal.

The host controller must generate a torque feed-forward reference.

Setting	Meaning
0	Does not use the torque feed-forward function.
1	Uses the torque feed-forward function.

- This function cannot be used with the function for torque restriction by analog voltage reference, described in *Section 3.2.9 Using Torque Restriction by Analog Voltage Reference*.
- For parameters and control modes, refer to *Appendix C List of Parameters*.

■ Setting a Torque Feed-forward Value in Parameter Cn-13

The factory setting is $Cn-13 = 30$. If, for example, the torque feed-forward value is ± 3 V, torque is restricted to $\pm 100\%$ (rated torque).

Cn-13	TCRFGN Torque Reference Gain	Unit: 0.1 V/Rated Torque	Setting Range: 10 to 100	Factory Setting: 30	For Speed/Torque Control Only
--------------	------------------------------------	--------------------------------	--------------------------------	---------------------------	----------------------------------

3.2.9 Using Torque Restriction by Analog Voltage Reference

For speed control (analog reference) only.

This function restricts torque by assigning the T-REF terminal (1CN-9, 1CN-10) a torque limit value in terms of analog voltage. Since torque reference input terminal T-REF is used as an input terminal, this function cannot be used for torque control.

Schematic Block Diagram for Torque Restriction by Analog Voltage Reference

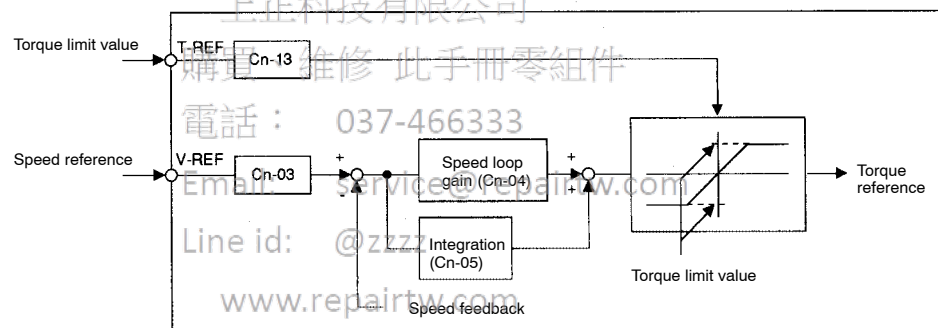

■ How to Use Torque Restriction by Analog Voltage Reference

To use this torque restriction function, set the following memory switch to 1.

Cn-02 Bit 8	Torque Restriction by Analog Voltage Reference	Factory Setting: 0	For Speed/Torque Control Only
--------------------	---	-----------------------	----------------------------------

Enables this torque restriction function.

To use this function, input a speed reference to the V-REF terminal and a torque limit value to the T-REF terminal.

This function cannot be used for torque control.

Torque restriction cannot be set separately for forward and reverse rotation. (The same setting applies to both forward and reverse rotation.)

Setting	Meaning
0	Does not use the T-REF terminal as a torque limit value input terminal.
1	Uses the T-REF terminal as a torque limit value input terminal.

- This function cannot be used with the torque feed-forward function described in Section 3.2.8 Using Torque Feed-forward Function.
- For parameters and control modes, refer to Appendix C List of Parameters.

■ Setting a Torque Limit Value in Parameter Cn-13

The factory setting is Cn-13 = 30. If, for example, the torque limit value is 3 V, torque is restricted to 100% (rated torque).

Cn-13	TCRFGN Torque Reference Gain	Unit: 0.1 V/ Rated Torque	Setting Range: 10 to 100	Factory Setting: 30	For Speed/Torque Control Only
--------------	------------------------------------	---------------------------------	--------------------------------	---------------------------	----------------------------------

上正科技有限公司

購買、維修 此手冊零組件

電話： 037-466333

Email: service@repairtw.com

Line id: @zzzz

www.repairtw.com

3.2.10 Using the Reference Pulse Inhibit Function (INHIBIT)

This function causes the SERVOPACK to stop counting input reference pulses in position control mode.

While this function is being used, the motor remains in servo locked (clamped) status. The /P-CON signal is used to enable or prohibit this function.

When this function is used, therefore, the /P-CON signal cannot be used to switch between proportion (P) control and proportional/integral (PI) control for speed loop. (PI control is always used.)

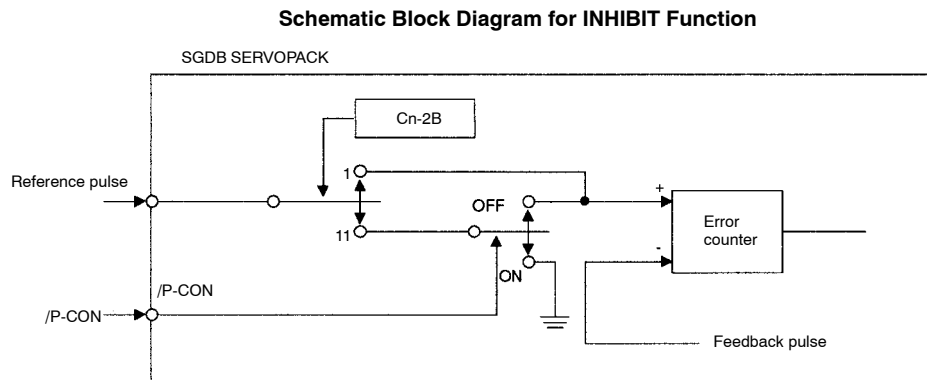

3

■ How to Use Reference Pulse Inhibit Function: INHIBIT

To use the INHIBIT function, set the Cn-2B constant as follows.

Cn-2B	Control Mode Selection	Factory Setting: 0	For Position Control Only
--------------	------------------------	--------------------	---------------------------

Enables the INHIBIT function.

Setting	Meaning						
0	Does not use the INHIBIT function. Reference pulses are always counted.						
1	<p>Uses the INHIBIT function. /P-CON signal is used to enable or prohibit the INHIBIT function.</p> <table border="1" style="width: 100%; border-collapse: collapse;"> <thead> <tr> <th style="width: 15%;">/P-CON</th> <th style="width: 85%;">Meaning</th> </tr> </thead> <tbody> <tr> <td style="text-align: center;">OFF</td> <td>Counts reference pulses.</td> </tr> <tr> <td style="text-align: center;">ON</td> <td>Prohibits the SERVOPACK from counting reference pulses. The motor remains in servo locked (clamped) status.</td> </tr> </tbody> </table>	/P-CON	Meaning	OFF	Counts reference pulses.	ON	Prohibits the SERVOPACK from counting reference pulses. The motor remains in servo locked (clamped) status.
/P-CON	Meaning						
OFF	Counts reference pulses.						
ON	Prohibits the SERVOPACK from counting reference pulses. The motor remains in servo locked (clamped) status.						

■ Relationship between INHIBIT Signal and Reference Pulse

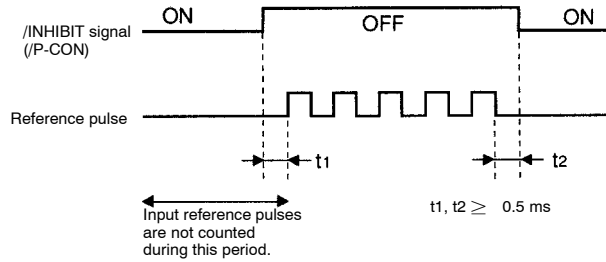

3.2.11 Using the Reference Pulse Input Filter Selection Function

This function selects a reference pulse input filter inside the SERVOPACK according to the output form of reference pulses from the host controller.

■ How to Use Reference Pulse Input Filter

Set the following memory switch according to the output form of reference pulses from the host controller:

Cn-02 Bit F	Reference Pulse Input Filter Selection Function	Factory Setting: 0	For Position Control Only
--------------------	---	--------------------	---------------------------

購買、維修 此手冊零組件

Sets the memory switch according to the output form (line driver or open collector) of reference pulses from the host controller.

電話: 057-460933
Email: service@repairtw.com

Setting	Meaning
0	Output form of reference pulses from host controller: Line driver output (maximum frequency of reference pulse: 450 kpps)
1	Output form of reference pulses from host controller: Open collector output (maximum frequency of reference pulse: 200 kpps)

For open collector output, the wire length must be as short as possible (maximum 3 m).

3.2.12 Using the Analog Monitor

The following two analog voltage monitor signals are output.

Output → TRQ-M 1CN-16	Torque Monitor	For Speed/Torque Control and Position Control
Output → VTG-M 1CN-17	Speed Monitor	For Speed/Torque Control and Position Control

The following memory switch is used to modify the signal specifications.

Cn-02	Bit 6	TRQ-M Specifications	Factory Setting: 0	
	Bit 7	VTG-M Specifications	Factory Setting: 0	
	Bit E	Error Pulse Monitor Level Changeover	Factory Setting: 0	

TRQ-M

Cn-02 Bit 6	Control Mode	Specifications
0	----	Torque monitor ($\mp 2V/\pm 100\%$ torque)
1	Torque control	(Undefined)
	Speed control	Speed reference monitor*
	Position control	Reference pulse speed monitor*

VTG-M

Cn-02 Bit 7	Control Mode	Specifications
0	----	Speed monitor*
1	Speed/torque control	(Undefined)
	Position control	Error pulse monitor Cn-02 bit E = 0: $\mp 0.05 V/\pm 1$ reference unit Cn-02 bit E = 1: $\mp 0.05 V/\pm 100$ reference units

- * For the SGMG and SGMD series, the unit is $\mp 2V/\pm 1000 \text{ min}^{-1}$.
For the SGMS, SGM and SGMP series, the unit is $\mp 1V/\pm 1000 \text{ min}^{-1}$.

Analog monitor can also be available with exclusive-use cable (type: DE9404559) from 5CN connector.

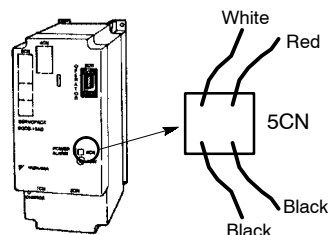

Cable Color	Signal Name	Contents
Red	VTG-M	Speed/error pulse monitor
White	TRQ-M	Torque/speed reference monitor
Black (x2)	GND	Grounding

3.3 Setting Up the Σ SERVOPACK

This section describes how to set parameters to operate the SGDB SERVOPACK.

3.3.1 Setting Parameters

Σ -series SERVOPACKs provide many functions, and have parameters to allow the user to specify each function and perform fine adjustment.

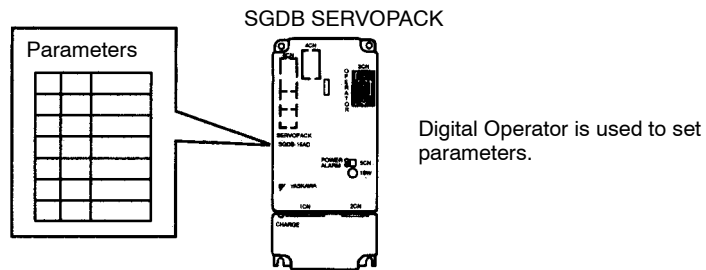

Parameters are divided into the following two types.

Memory switch Cn-01, Cn-02	Each bit of this switch is turned ON or OFF to specify a function.
Parameter setting Cn-03 and later	A numerical value such as a torque limit value or speed loop gain is set in this parameter.

Parameter	Name and Code		Remarks
Cn-01	Memory switch		Each bit number has a switch (ON/OFF).
Cn-02	Memory switch		
Cn-03	VREFGN	Speed reference gain	Parameter setting
Cn-..	
Cn-..	
Cn-2D	OUTSEL	Output signal selection	

For a list of parameters, refer to *Appendix C List of Parameters*.

For details of how to set parameters, refer to *Section 4.1.6 Operation in Parameter Setting Mode*

3.3.2 Setting the Jog Speed

Use the following parameter to set or modify a motor speed when operating the Σ -series Servo from a Digital Operator:

Cn-10	JOGSPD Jog Speed	Unit: min ⁻¹	Setting Range: 0 to 10000	Factory Setting: 500	For Speed/Torque Control and Position Control
--------------	---------------------	----------------------------	---------------------------------	----------------------------	---

This parameter is used to set a motor speed when the motor is operated using a Digital Operator.

If a value higher than the maximum speed is set, the maximum speed value is used.

Operation Using Digital Operator

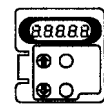

上正科技有限公司
 購買、維修 此手冊零組件
 電話： 037-466333
 Email: service@repairtw.com
 Line id: @zzzz
 www.repairtw.com

3.3.3 Setting the Number of Encoder Pulses

To ensure that the Σ -series Servo System operates properly, set the type of the encoder to be used and the number of encoder pulses per revolution in the following parameters:

Cn-01 Bit E	Encoder Type Selection	Factory Setting: 0	For Speed/Torque Control and Position Control
--------------------	------------------------	--------------------	---

Set the encoder type according to the servomotor type to be used.

After changing the memory switch setting, turn the power OFF, then ON.

Motor Type encoder specifications	Number of Encoder Pulses Per Revolution	Preset Value
2	Incremental encoder: 8192 pulses per revolution	0
3	Incremental encoder: 2048 pulses per revolution	
6	Incremental encoder: 4096 pulses per revolution	
W	Absolute encoder: 1024 pulses per revolution	1
S	Absolute encoder: 8192 pulses per revolution	

Cn-11	PULSNO Number of Encoder Pulses	Unit: Pulses Per Revolution	Setting Range: Number of Encoder Pulses		For Speed/Torque Control and Position Control
--------------	------------------------------------	-----------------------------	--	--	---

Set the number of encoder pulses according to the servomotor type to be used. If this parameter is set incorrectly, system operation cannot be guaranteed.

After changing the memory switch setting, turn the power OFF, then ON.

Motor Type encoder specifications	Number of Encoder Pulses Per Revolution	Preset Value
2	Incremental encoder: 8192 pulses per revolution	8192
3	Incremental encoder: 2048 pulses per revolution	2048
6	Incremental encoder: 4096 pulses per revolution	4096
W	Absolute encoder: 1024 pulses per revolution	1024
S	Absolute encoder: 8192 pulses per revolution	8192

3.3.4 Setting the Motor Type

To ensure that the Σ -series Servo System operates properly, set the type of the servomotor to be used in the following parameter.

Cn-2A	Motor Selection	For Speed/Torque Control and Position Control
--------------	-----------------	---

Set this memory switch according to the servomotor type to be used. After changing the parameter setting, turn the power OFF, then ON.

Group	SERVOPACK Type	Motor Type	Cn-2A Setting
05	SGDB-03ADM	SGMG-03A□B	171
	SGDB-05AD	SGM-04A	106
	SGDB-05ADP	SGMP-04A	126
	SGDB-05ADG	SGMG-05A□A	142
10	SGDB-07ADM	SGMG-06A□B	172
	SGDB-10AD	SGM-08A	107
	SGDB-10ADP	SGMP-08A	127
	SGDB-10ADG	SGMG-09A□A	143
	SGDB-10ADM	SGMG-09A□B	173
	SGDB-10ADS	SGMS-10A□A	163
15	SGDB-15ADM	SGMG-12A□B	174
	SGDB-15ADG	SGMG-13A□A	144
	SGDB-15ADP	SGMP-15A	128
	SGDB-15ADS	SGMS-15A□A	164
20	SGDB-20ADG	SGMG-20A□A	145
	SGDB-20ADM	SGMG-20A□B	175
	SGDB-20ADS	SGMS-20A□A	165
30	SGDB-30ADD	SGMD-22A□A	155
	SGDB-30ADG	SGMG-30A□A	146
	SGDB-30ADM	SGMG-30A□B	176
	SGDB-30ADS	SGMS-30A□A	166
44	SGDB-44ADD	SGMD-32A□A	156
	SGDB-44ADG	SGMG-44A□A	147
	SGDB-44ADM	SGMG-44A□B	177
	SGDB-44ADS	SGMS-40A□A	167
	SGDB-50ADD	SGMD-40A□A	157
	SGDB-50ADS	SGMS-50A□A	168
60	SGDB-60ADG	SGMG-55A□A	148
	SGDB-60ADM	SGMG-60A□B	178
75	SGDB-75ADG	SGMG-75A□A	149
1A	SGDB-1AADG	SGMG-1AA□A	140
1E	SGDB-1EADG	SGMG-1EA□A	150

The motor type used can be changed within the same group by altering the Cn-2A setting.

3.3.5 Adjusting the Encoder Supply Voltage

The encoder power voltage at the encoder input part must be between 4.75 and 5.25 V. If the encoder cable is long, adjust the encoder supply voltage by setting the following parameter.

Cn-2C	Encoder Power Voltage Adjustment	Unit: 0.1 mV	Factory Setting: 52500	For Speed/Torque Control and Position Control
--------------	----------------------------------	--------------	------------------------	---

The following values apply to standard cables:

Encoder \ Length of cables	3 m	5 m	10 m	15 m	20 m
15-bit absolute encoder	52500			55000	57000
12-bit absolute encoder Incremental encoder				54000	55500

Note that the system may fail to operate normally or break down if the setting is too high or too low.

上正科技有限公司

購買、維修 此手冊零組件

電話： 037-466333

Email: service@repairtw.com

Line id: @zzzz

www.repairtw.com

3.4 Setting Stop Mode

This section describes how to stop the motor properly.

3.4.1 Adjusting Offset

■ “Why Does not the Motor Stop?”

When 0 V is specified as reference voltage for speed/torque control (analog reference), the motor may rotate at a very slow speed and fail to stop. This happens when reference voltage from the host controller or external circuit has a slight reference offset (in mV units). If this offset is adjusted to 0 V, the motor will stop.

When reference voltage from the host controller or external circuit has an offset

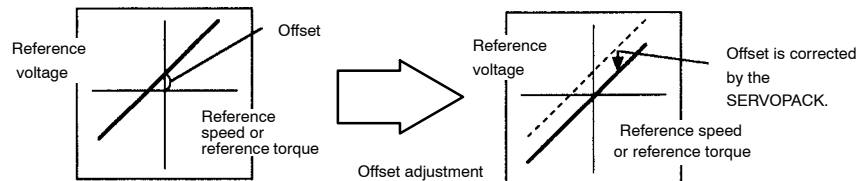

■ Adjusting the Reference Offset

The following two methods can be used to adjust the reference offset to 0 V.

Automatic adjustment of reference offset	Reference offset is automatically adjusted to 0 V.
Manual adjustment of reference offset	Reference offset can be intentionally set to a specified value.

NOTE If a position control loop is formed in the host controller, do not use automatic adjustment in 1. Always use manual adjustment in 2.

上正科技有限公司

購買、維修 此手冊零組件

電話：037-466333

Email: service@repairtw.com

line id: @zzz4

www.repairtw.com

For detailed adjustment procedures, refer to the following sections.

	Adjustment Method
Automatic adjustment of reference offset	Section 4.2.4 Reference Offset Automatic Adjustment
Manual adjustment of reference offset	Section 4.2.5 Reference Offset Manual Adjustment Mode

3.4.2 Using Dynamic Brake

To stop the servomotor by applying **dynamic brake (DB)**, set desired values in the following memory switch. If dynamic brake is not used, the servomotor will stop naturally due to machine friction.

Cn-01 Bit 6	How to Stop Motor When Servo is Turned OFF	Factory Setting: 0	For Speed/Torque Control and Position Control
Cn-01 Bit 7	Operation to Be Performed When Motor Stops After Servo is Turned OFF		For Speed/Torque Control and Position Control

The SERVOPACK enters servo OFF status when:

- Servo ON input signal (/S-ON, 1CN-40) is turned OFF
- Servo alarm arises
- Power is turned OFF

Specify how to stop the motor when one of the above events occurs during operation.

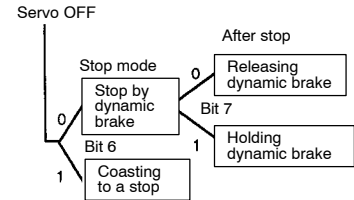

	Setting	Meaning
Cn-01 bit 6	0	Stops the motor by dynamic brake.
	1	Causes the motor to coast to a stop. The motor power is OFF and stops due to machine friction.

If dynamic brake stop mode is selected, specify the operation to be performed when the motor stops.

	Setting	Meaning
Cn-01 bit 7	0	Releases dynamic brake after the motor stops.
	1	Does not release dynamic brake even after the motor stop.

For 2.0 kW type, bit 7 of Cn-01 can be set to 0 only.



Dynamic brake (DB)

One of the general methods to cause a motor sudden stop. "Dynamic brake" suddenly stops a servomotor by shorting its electrical circuit. This dynamic brake circuit is incorporated in the SERVOPACK.

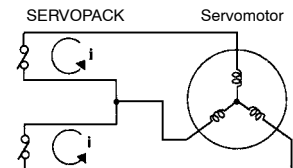

3.4.3 Using Zero-Clamp

The zero-clamp function is used for a system in which the host controller does not form a position loop by speed reference input.

In other words, this function is used to cause the motor to stop and enter a servo locked status when the input voltage of speed reference V-REF is not 0 V. When the zero-clamp function is turned ON, an internal position loop is temporarily formed, causing the motor to be clamped within one pulse. Even if the motor is forcibly rotated by external force, it returns to the zero-clamp position.

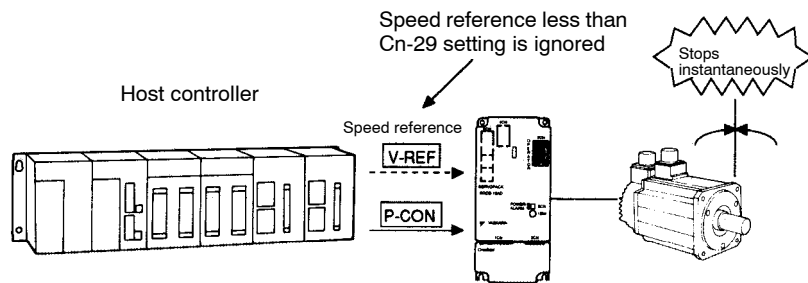

■ Setting Memory Switch

Set the following memory switch so that input signal $\overline{P-CON}$ can be used to enable or disable the zero-clamp function.

Cn-2B	Control Mode Selection	Factory Setting:0	For Speed Control Only
-------	------------------------	-------------------	------------------------

→ Input $\overline{P-CON}$ 1CN-41	Proportional Control, etc.	For Speed/Torque Control and Position Control
-----------------------------------	----------------------------	---

Cn-2B	Control Mode					
10	<p>Zero-clamp Speed Control</p> <p>This speed control allows the zero-clamp function to be set when the motor stops.</p> <ul style="list-style-type: none"> A speed reference is input from V-REF (1CN-5). $\overline{P-CON}$ (1CN-41) is used to turn the zero-clamp function ON or OFF. <table border="1"> <tr> <td>$\overline{P-CON}$ (1CN-41) is open (OFF)</td> <td>Turns zero-clamp function OFF</td> </tr> <tr> <td>$\overline{P-CON}$ (1CN-41) is closed (0V)</td> <td>Turns zero-clamp function ON</td> </tr> </table>	$\overline{P-CON}$ (1CN-41) is open (OFF)	Turns zero-clamp function OFF	$\overline{P-CON}$ (1CN-41) is closed (0V)	Turns zero-clamp function ON	<p>SGDB SERVOPACK</p> <p>Zero-clamp is performed when the following two conditions are met: $\overline{P-CON}$ signal is closed. Motor speed is below the value set in Cn-29 (ZCLVL).</p>
$\overline{P-CON}$ (1CN-41) is open (OFF)	Turns zero-clamp function OFF					
$\overline{P-CON}$ (1CN-41) is closed (0V)	Turns zero-clamp function ON					

■ Settings

Set in the following parameter the motor speed level at which zero-clamp is to be performed:

Cn-29	ZCLVL Zero-Clamp Level	Unit: min ⁻¹	Setting Range: 0 to 10000	Factory Setting: 10	For Speed Control Only
--------------	---------------------------	----------------------------	------------------------------	---------------------------	---------------------------

If zero-clamp speed control is selected, set the motor speed level at which zero-clamp is to be performed. If a value higher than the maximum motor speed is set, the maximum speed value is used.

Conditions for Zero-clamp

Zero-clamp is performed when all the following conditions are met:

- Zero-clamp speed control is selected (Parameter Cn-2B=10).
- /P-CON (1CN-41) is turned ON (0 V).
- Motor speed drops below the preset value.

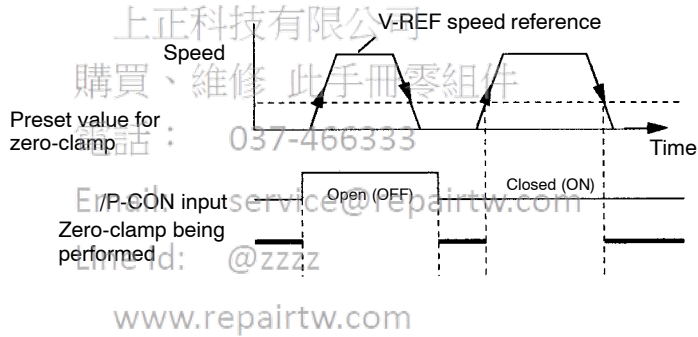

3.4.4 Using Holding Brake

Holding brake is useful when a servo drive is used to control a vertical axis. A servomotor with brake prevents the movable part from dropping due to gravitation when the system power is turned OFF.

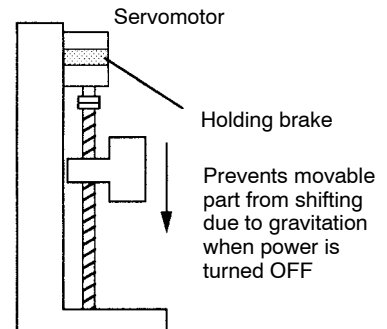

When using the holding brake, turn ON and OFF the brake with the following timing because a delay occurs. The brake interlock is useful for adjusting the timing.

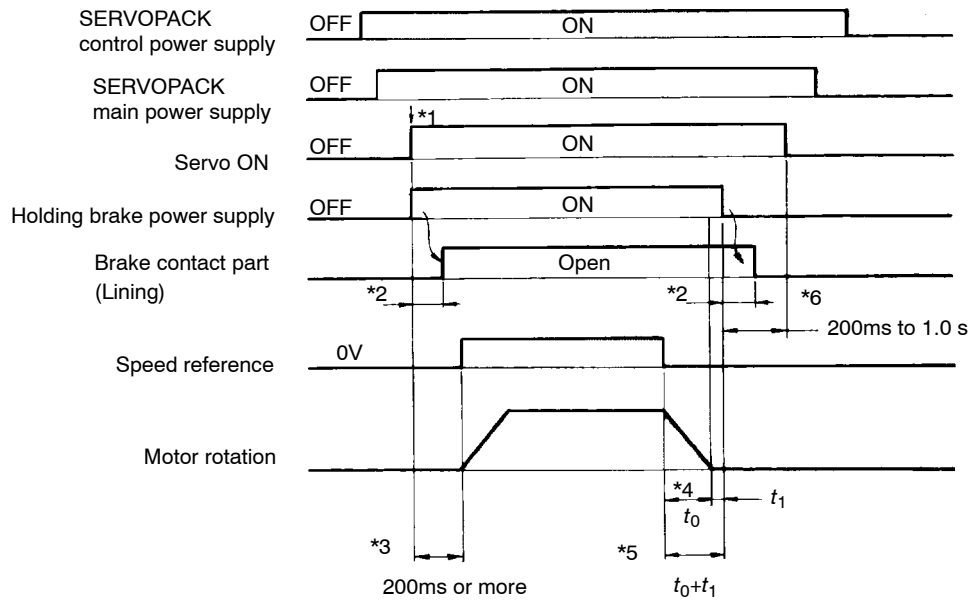

- * 1 Apply the holding brake at the same time as the Servo ON.
- * 2 The mechanical contact takes 180 ms max. to be opened when the brake is turned ON and 100 ms max. to be closed when turned OFF.
- * 3 Allow 200 ms or more between the moment when the brake is turned ON and when the speed reference is input.
- * 4 t_0 indicates the motor stopping time. The table below shows the formula.
- * 5 Do not turn OFF the brake power supply before the motor stops. Normally, $t_0 + t_1$ is approx. 1 to 2 seconds.
- * 6 In 0.2 to 1.0 seconds after turning OFF the brake power supply, turn OFF the servo ON.

Using SI Units	Using Gravitational Units
$t_o = \frac{(J_M + J_L) \times N_M}{(T_p + T_L)} \text{ (s)}$	$t_o = \frac{(GD_M^2 + GD_L^2) \times N_M}{375 \times (T_p + T_L)} \text{ (s)}$
J_M : Rotor moment of inertia (kg·m ²)	GD_M^2 : Motor GD ² (kg·m ²)
J_L : Load moment of inertia (kg·m ²)	GD_L^2 : Load GD ² (kg·m ²)
N_M : Motor speed (min ⁻¹)	N_M : Motor speed (min ⁻¹)
T_p : Motor deceleration torque (N·m)	T_p : Motor deceleration torque (kg·m)
T_L : Load torque (N·m)	T_L : Load torque (kg·m)

NOTE The built-in brake in servomotor with brake is a de-energization operation type, which is used for holding purposes only and cannot be used for braking purposes. Use the holding brake only to retain a stopped motor. Brake torque is more than about 120% of the rated motor torque.

■ Connection Example

Use SERVOPACK contact output-signal /BK and brake power supply to form a brake ON/OFF circuit.

An example of standard wiring is shown below.

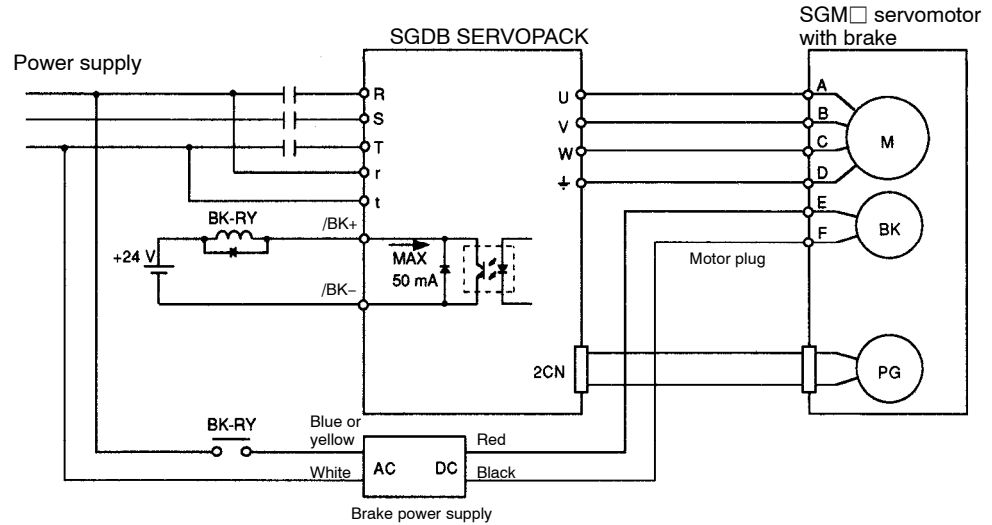

BK-RY: Brake control relay

Brake power supply has two types (200 V, 100 V).

Output → /BK	Brake Interlock Output	For Speed/Torque Control and Position Control
---------------------	------------------------	---

This output signal controls the brake when a motor with brake is used. This signal terminal need not be connected when a motor without brake is used.

Related Parameters

Cn-12	Time delay from brake signal until servo OFF
Cn-15	Speed level for brake signal output during operation
Cn-16	Output timing of brake signal during motor operation

ON Status: Circuit is closed or signal is at low level.	Releases the brake.
OFF Status: Circuit is open or signal is at high level.	Applies the brake.

Set the following parameter to specify the 1CN pin to which the BK signal is output.

Cn-2D	OUTSEL Output Signal Selection	Setting Range: 110 to 666	Factory Setting: 210	For Speed/Torque Control and Position Control
--------------	--------------------------------	------------------------------	-------------------------	---

This parameter is used to select a function signal as the 1CN output signal.

1s place	Select the 1CN-25 and 1CN-26 (/COIN, /V-CMP) functions.
10s place	Select the 1CN-27 and 1CN-28 (TGON) functions.
100s place	Select the 1CN-29 and 1CN-30 (/S-RDY) functions.

Example: /BK is output to 1CN-27 and 1CN-28.

Cn-2D=□4□

Preset value	Function
0	/COIN, /V-CMP (Can be allocated to 1CN-25 and 1CN-26 only.)
1	/TGON
2	/S-RDY
3	/CLT
4	/BK
5	Overload warning
6	Overload alarm

■ Brake ON Timing

If the machine moves slightly due to gravity when the brake is applied, set the following parameter to adjust brake ON timing:

Cn-12	BRKTIM	Time delay from the time a brake signal is output until servo OFF status occurs	Unit: 10 ms	Setting Range: 0 to 50	Factory Setting: 0	For Speed/Torque Control and Position Control

This parameter is used to set output timing of brake control signal /BK and servo OFF operation (motor output stop) when SGM□ servomotor with brake is used.

Brake Timing when Motor is in Stopped Status

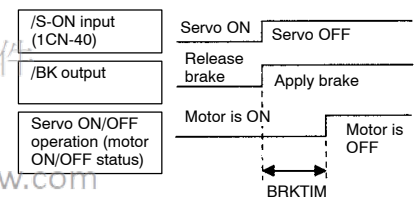

With the standard setting, the servo is turned OFF when /BK signal (brake operation) is output. The machine may move slightly due to gravitation. This movement depends on machine configuration and brake characteristics. If this happens, use this parameter to delay servo OFF timing to prevent the machine from moving.

For brake ON timing during motor operation, use Cn-15 and Cn-16.

■ Settings

Set the following parameters to adjust brake ON timing so that holding brake is applied when the motor stops.

Cn-15	BRKSPD	Speed Level at which Brake Signal Is Output during Motor Operation	Unit: min ⁻¹	Setting Range: 0 to 10000	Factory Setting: 100	For Speed/Torque Control and Position Control
Cn-16	BRKWAI	Output Timing of Brake Signal during Motor Operation	Unit: 10 ms	Setting Range: 10 to 100	Factory Setting: 50	For Speed/Torque Control and Position Control

Cn-15 and Cn-16 are used for SGM servomotors with brake. Use these parameters to set brake timing used when the servo is turned OFF by input signal /S-ON (1CN-40) or alarm occurrence during motor rotation.

Brakes for SGM servomotors are designed as holding brakes. Therefore, brake ON timing when the motor stops must be appropriate. Adjust the parameter settings while observing machine operation.

Brake Timing when Motor is in Stopped Status

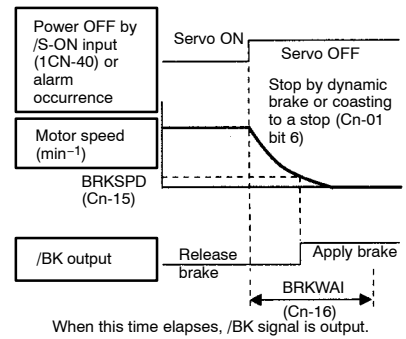

- Conditions for /BK signal output during motor operation. The circuit is opened in either of the following situations.

1	Motor speed drops below the value set in Cn-15 (BRKSPD) after servo OFF occurs.
2	The time set in Cn-16 (BRKWAI) has elapsed since servo OFF occurred.

If a value higher than the maximum speed is set, the maximum speed value is used.

上正科技有限公司

購買、維修、此手冊零組件

電話：037-466333

Email: service@repairtw.com

www.repairtw.com

3.5 Running the Motor Smoothly

This section explains how to run the servomotor smoothly.

3.5.1 Using the Soft Start Function

The soft start function adjusts progressive speed reference input inside the SERVOPACK so that acceleration and deceleration can be as constant as possible. To use this function, set the following parameters.

Cn-07	SFSACC Soft Start Time (Acceleration)	Unit: ms	Setting Range: 0 to 10000	Factory Setting: 0	For Speed Control Only
Cn-23	SFSDEC Soft Start Time (Deceleration)	Unit: ms	Setting Range: 0 to 10000	Factory Setting: 0	For Speed Control Only

In the SERVOPACK, a speed reference is multiplied by the acceleration or deceleration value set in Cn-07 or Cn-23 to provide speed control.

Smooth speed control can be achieved when progressive speed references are input or when contact input speed control is used. Normally, set these to "0".

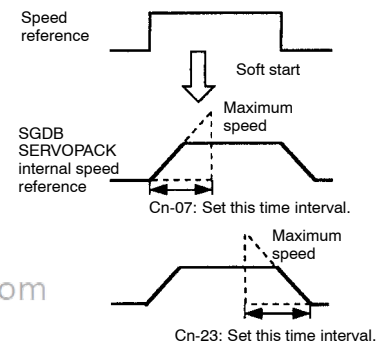

Set these parameters as follows:

Cn-07: Time interval from the time the motor starts until the maximum speed is reached

Cn-23: Time interval from the time the motor is running at the maximum speed until it stops

3.5.2 Using the Smoothing Function

The smoothing function adjusts constant-frequency reference input inside the SERVOPACK so that acceleration and deceleration can be as constant as possible. To use this function, set the following parameter.

Cn-26	ACCTME	Position Reference Acceleration/Deceleration Time Constant (Smoothing)	Unit: 0.1 ms	Setting Range: 0 to 640	Factory Setting: 0	For Position Control Only
--------------	--------	--	--------------	-------------------------	--------------------	---------------------------

This function performs acceleration/deceleration processing for input reference pulses (primary lag characteristics).

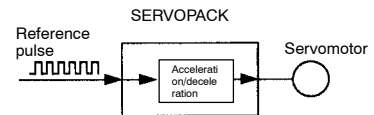

This function prevents the motor from running at progressive speeds in the following cases:

- When the host controller which outputs references cannot perform acceleration/deceleration processing
- When reference pulse frequency is too low
- When reference electronic gear ratio is too high (more than 10 times)

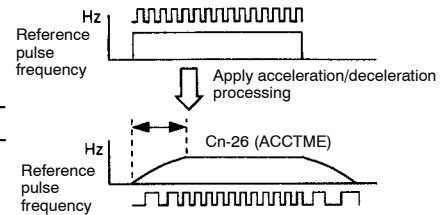

This function does not change the travel distance (number of pulses).

3.5.3 Adjusting Gain

If speed loop gain or position loop gain exceeds the allowable limit for the servo system including the machine to be controlled, the system will vibrate or become too susceptible. Under such conditions, smooth operation cannot be expected. Reduce each loop gain value to an appropriate value.

For servo gain adjustment, refer to the following section:

Section 3.6.2 Setting Servo Gain

上正科技有限公司

購買、維修 此手冊零組件

電話： 037-466333

www.repairtw.com

3.5.4 Adjusting Offset

If reference voltage from the host controller or external circuit has an offset in the vicinity of 0 V, smooth operation cannot be expected. Adjust the reference offset to 0 V.

When Reference Voltage from Host Controller or External Circuit has an Offset

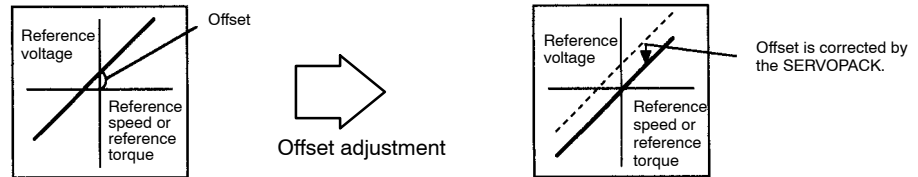

The following two methods are available to adjust the reference offset to 0 V.

Automatic adjustment of reference offset	Reference offset is automatically adjusted.
Manual adjustment of reference offset	Reference offset can be intentionally set to a specified value.

NOTE If a position control loop is formed in the host controller, do not use automatic adjustment. Always use manual adjustment.

For detailed adjustment procedures, refer to the following sections:

	Adjustment Method
Automatic adjustment of reference offset	Section 4.2.4 Reference Offset Automatic Adjustment
Manual adjustment of reference offset	Section 4.2.5 Reference Offset Manual Adjustment Mode

3.5.5 Setting the Torque Reference Filter Time Constant

If the machine causes vibration, possibly resulting from the servo drive, adjust the following filter time constant. Vibration may stop.

Cn-17	TRQFIL Torque Reference Filter Time Constant	Unit: 100 μ s	Setting Range: 0 to 250	For Speed/Torque Control and Position Control
--------------	--	----------------------	----------------------------	---

Cn-17 is a torque reference filter time constant for the SGDB SERVOPACK. The smaller the value, the higher the torque control response. There is, however, a certain limit depending on machine conditions.

With the standard setting, the machine may cause vibration resulting from the servo drive. In this case, increase the constant setting. Vibration may stop. Vibration can be caused by incorrect gain adjustment, machine problems and so on.

■ Switching Torque Reference Filter

The following memory switch can be used to switch between the primary and secondary torque reference filters. The filter to be used depends on machine characteristics. If vibration occurs, select the appropriate filter by changing the memory switch setting.

Cn-02 Bit C	Torque Reference Filter Selection	Factory Setting: 0		For Speed/Torque Control and Position Control
--------------------	-----------------------------------	-----------------------	--	---

- 0: Primary filter
- 1: Secondary filter

上正科技有限公司

購買、維修 此手冊零組件

電話： 037-466333

Email: service@repairtw.com

Line id: @zzzz

www.repairtw.com

3.6 Minimizing Positioning Time

This section describes how to minimize positioning time.

3.6.1 Using Autotuning Function

If speed loop gain and position loop gain for the servo system are not set properly, positioning may become slow. Techniques and experience are required to set these servo gain values according to machine configuration and machine rigidity.

Σ -series SERVOPACKs have an autotuning function that automatically measures machine characteristics and sets the necessary servo gain values. With this function, even first-time servo users can easily perform tuning for servo gain. Servo gain values are set in parameters.

The following parameters can be automatically set by the autotuning function.

Parameter	Meaning
Cn-04	Speed loop gain
Cn-05	Speed loop integration time constant
Cn-1A	Position loop gain

For details of how to perform autotuning, refer to *Section 4.2.3 Autotuning*

3.6.2 Setting Servo Gain

Check and reset the servo gain when:

- Automatically set servo gain values need to be checked after autotuning.
- Each servo gain value checked as described above is to be directly set for another SERVOPACK.
- Response performance needs to be further enhanced after autotuning, or servo gain values need to be reset for a system with lower response performance.

■ Setting Speed Loop

Set the following parameters related to speed loop as necessary.

Cn-04	LOOPHZ Speed Loop Gain (Kv)	Unit: Hz	Setting Range: 1 to 2000	Factory Setting: 80	For Speed/Torque Control and Position Control
Cn-05	PITIME Speed Loop Integration Time Constant (Ti)	Unit: 0.01 ms	Setting Range: 200 to 51200	Factory Setting: 2000	For Speed/Torque Control and Position Control

Cn-04 and Cn-05 are a speed loop gain and an integration time constant for the SERVOPACK, respectively.

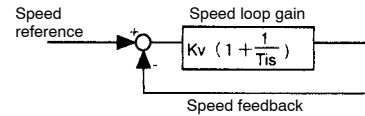

The higher the speed loop gain value or the smaller the speed loop integration time constant value, the higher the speed control response. There is, however, a certain limit depending on machine characteristics.

Note If the Cn-28 constant is set, the maximum allowable Cn-04 setting may become smaller than 2000.

The unit of speed loop gain (Kv) is Hz, but this value is obtained when J_M equals J_L . Therefore, the value must be converted using load $J (= J_L)$ as follows:

$$Kv \text{ value} = \frac{\text{setting} \times 2}{1 + (J_L/J_L)}$$

These parameters are automatically set by the autotuning function.

The unit of speed loop integration time constant Cn-05 (Ti) can be changed to 0.01 ms.

■ Setting Position Loop

Set the following parameters related to position loop as necessary.

Cn-1A	POSGN Position Loop Gain (Kp)	Unit: 1/s	Setting Range: 1 to 200	Factory Setting: 40	For Position Control Only
--------------	----------------------------------	--------------	-------------------------------	---------------------------	------------------------------

This parameter is a position loop gain for the SERVOPACK.

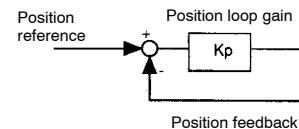

Increasing the position loop gain value provides position control with higher response and less error. However, there is a certain limit depending on machine characteristics. This gain is also valid for zero clamp operation.

This parameter is automatically set by the autotuning function.

Cn-1E	OVERLV Overflow	Unit: 256 References	Setting Range: 1 to 32767	Factory Setting: 1024	For Position Control Only
--------------	--------------------	-------------------------	---------------------------------	-----------------------------	------------------------------

Set in this parameter the error pulse level at which a position error pulse overflow alarm (alarm A.31) is detected.

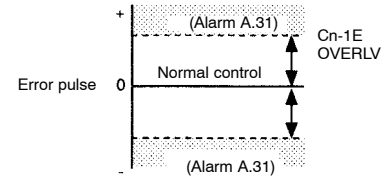

If the machine permits only a small position loop gain value to be set in Cn-1A, an overflow alarm may arise during high-speed operation. In this case, increase the value set in this parameter to suppress alarm detection.

3.6.3 Using Feed-forward Control

Feed-forward control shortens positioning time. To use **feed-forward control**, set the following parameter.

Cn-1D	FFGN Feed-forward Gain	Unit: %	Setting Range: 0 to 100	Factory Setting: 0	For Position Control Only
--------------	---------------------------	------------	-------------------------------	-----------------------	------------------------------

This parameter is set to apply feed-forward frequency compensation to position control inside the SERVOPACK.

Use this parameter to shorten positioning time.

Too high a value may cause the machine to vibrate. For ordinary machines, set 80% or less in this constant.

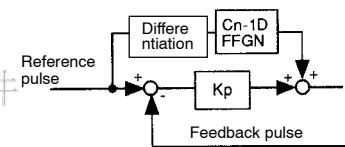

Line id: @zzzz

www.repairtw.com

3.6.4 Using Proportional Control

If parameter Cn-2B is set to 0 or 1 as shown below, input signal /P-CON serves as a PI/P control changeover switch.

- PI Control: Proportional/Integral control



Feed-forward control

Control for making necessary corrections beforehand to prevent the control system from receiving the effects of disturbance.

Using feed-forward control increases effective servo gain, enhancing response performance.

3.6.5 Setting Speed Bias

- P Control: Proportional control

Cn-2B	Control Mode Selection	Factory Setting: 0	For Speed Control and Position Control
--------------	------------------------	--------------------	--

Cn-2B	Control Mode					
0, 1	<p>Speed Control, Position Control This is normal speed control or position control.</p> <ul style="list-style-type: none"> • Signal P-CON (1CN-41) is used to switch between P control and PI control. <table border="1"> <tr> <td>P-CON (1CN-41) is open (OFF)</td> <td>PI control</td> </tr> <tr> <td>P-CON (1CN-41) is closed (0V)</td> <td>P control</td> </tr> </table>	P-CON (1CN-41) is open (OFF)	PI control	P-CON (1CN-41) is closed (0V)	P control	<p>The diagram shows a box labeled 'SGDB SERVOPACK' with a terminal '1CN-41'. A line labeled 'P/PI changeover P-CON' points to this terminal.</p>
P-CON (1CN-41) is open (OFF)	PI control					
P-CON (1CN-41) is closed (0V)	P control					

3

■ How To Use Proportional Control

Proportional control can be used in the following two ways.

- When operation is performed by sending speed references from the host controller to the SERVOPACK, the host controller can selectively use P control mode for particular conditions only. This method can prevent the occurrence of overshoot and also shorten settling time. For particular conditions, refer to *Section 3.6.6 Using Mode Switch*.
- If PI control mode is used when the speed reference has a reference offset, the motor may rotate at a very slow speed and fail to stop even if 0 is specified as a speed reference. In this case, use P control mode to stop the motor.

www.repairtw.com
 購買、維修、此手冊零組件
 電話: 03-486333
 Email: service@repairtw.com
 line id: @zzzz

3.6.5 Setting Speed Bias

The settling time for positioning can be reduced by assigning bias to the speed reference output part in the SERVOPACK. To assign bias, use the following constant.

Cn-1C	BIASLV Bias	Unit: min ⁻¹	Setting Range: 0 to 450	Factory Setting: 0	For Position Control Only
--------------	----------------	----------------------------	-------------------------	--------------------	---------------------------

This parameter is set to assign an offset to a speed reference in the SGDB SERVOPACK. (In position control mode)

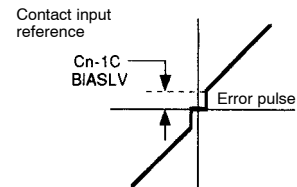

Use this constant to reduce the settling time.

Set this parameter according to machine conditions.

3.6.6 Using Mode Switch

Use the mode switch for the following purposes:

- To prevent overshoot during acceleration or deceleration (for speed control).
- To prevent undershoot during positioning in order to reduce settling time (for position control).

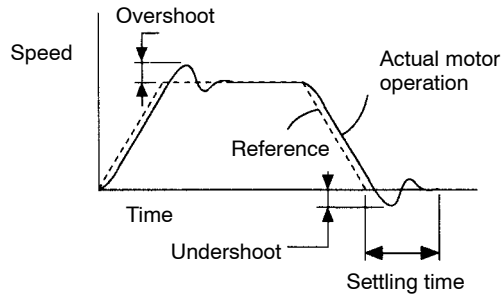

In other words, the mode switch is a function that automatically switches the speed control mode inside the SERVOPACK **from PI control to P control** while certain conditions are being established.

NOTE The mode switch is used to fully utilize performance of a servo drive to achieve very high-speed positioning. The speed response waveform must be observed to adjust the mode switch.

For normal use, the speed loop gain and position loop gain set by autotuning provide sufficient speed/position control.

Even if overshoot or undershoot occurs, they can be suppressed by setting the acceleration/deceleration time constant for the host controller, the soft start time constants (Cn-07, Cn-23), or smoothing time constant (Cn-26) for the SERVOPACK.

Line id: @zzzz

www.repairtw.com



From PI control to P control

PI control means proportional/integral control and P control means proportional control. In short, switching “from PI control to P control” reduces effective servo gain, making the servo system more stable.

■ Selecting a Mode Switch

SERVOPACKs can use four types of mode switches. To select a mode switch, use the following memory switch.

Memory Switch Cn-01			Mode Switch Setting	Parameter	Unit
Bit D	Bit C	Bit B			
-	-	1	Does not use mode switch.		
0	0	0	Uses torque reference as a detection point. (Standard setting)	Cn-0C	Percentage of rated torque: %
0	1	0	Uses speed reference as a detection point.	Cn-0D	Motor speed: min ⁻¹
1	0	0	Uses acceleration reference as a detection point.	Cn-0E	Motor acceleration: 10 (min ⁻¹)/s
1	1	0	Uses error pulse as a detection point.	Cn-0F	Reference unit

When Torque Reference Is Used as a Detection Point of Mode Switch (Standard Setting)

If a torque reference exceeds the torque value set in parameter Cn-0C, the speed loop switches to P control.

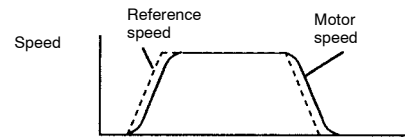

The SGDB SERVOPACK is factory set to this standard mode (Cn-0C = 200).

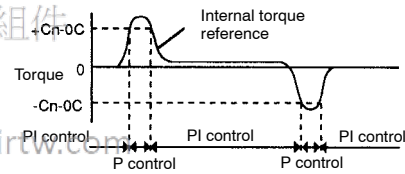

Example of Use: Email: service@repairtw.com

Line id: @zzzz

If a mode switch is not used and PI control is always performed, torque may enter a saturation state during acceleration or deceleration, causing the motor speed to have overshoot or undershoot.

Using the mode switch suppresses torque saturation and prevents the motor speed from having overshoot and undershoot.

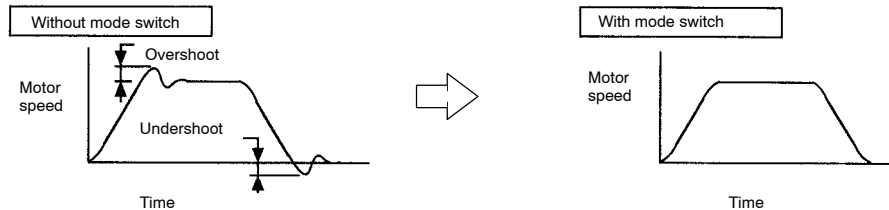

When Speed Reference Is Used as a Detection Point of Mode Switch

If a speed reference exceeds the value set in parameter Cn-0D, the speed loop switches to P control.

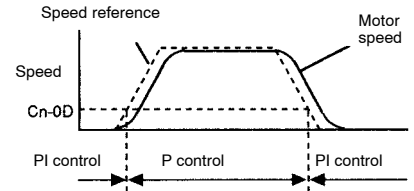

Example of Use:

The mode switch is used to reduce settling time.

Generally, speed loop gain must be increased to reduce settling time. Using the mode switch suppresses the occurrence of overshoot and undershoot when speed loop gain is increased.

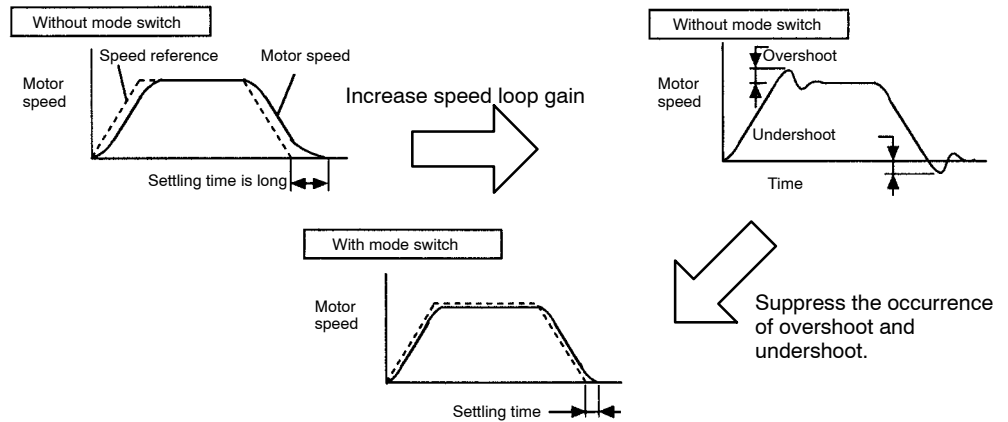

3

When Acceleration Is Used as a Detection Point of Mode Switch

If motor acceleration exceeds the value set in parameter Cn-0E, the speed loop switches to P control.

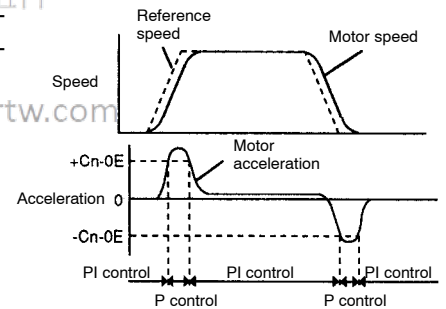

Example of Use:

If a mode switch is not used and PI control is always performed, torque may enter a saturation state during acceleration or deceleration, causing the motor speed to have overshoot or undershoot.

Using the mode switch suppresses torque saturation and prevents the motor speed from having overshoot and undershoot.

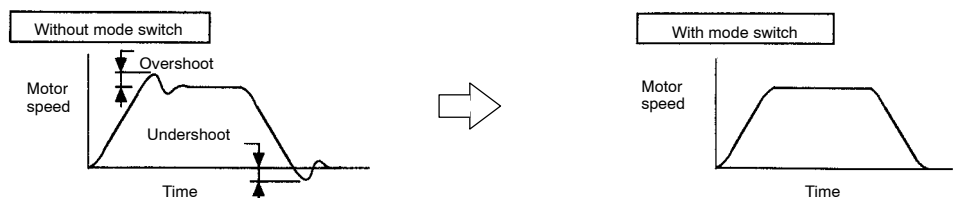

When Error Pulse Is Used as a Detection Point of Mode Switch

This is for position control only.

If an error pulse exceeds the value set in parameter Cn-0F, the speed loop switches to P control.

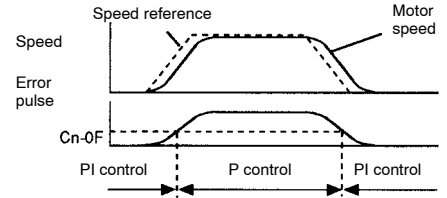

Example of Use:

The mode switch is used to reduce settling time.

Generally, speed loop gain must be increased to reduce settling time. Using the mode switch suppresses the occurrence of overshoot and undershoot when speed loop gain is increased.

3

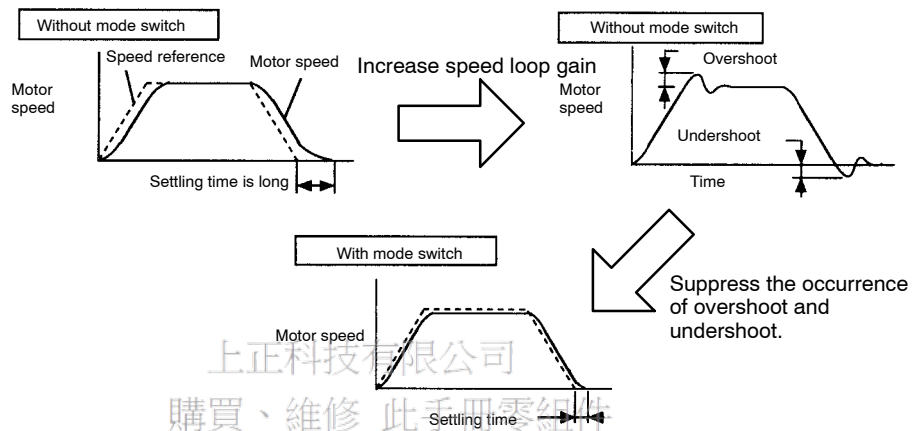

■ Parameters

Email: service@repairtw.com

The parameters required to set each mode switch are summarized as follows.

www.repairtw.com

Cn-01Bit B	Mode Switch ON/OFF	Factory Setting: 0	For Speed Control and Position Control
-------------------	--------------------	--------------------	--

This parameter is used to enable or disable the mode switch function.

Setting	Meaning
0	Uses the mode switch function
1	Does not use the mode switch function

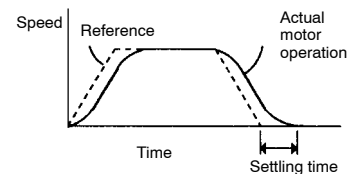

Mode switch is used to reduce settling time and suppress undershoot when the motor stops. It switches PI control to P control when certain conditions are met.

The SERVOPACK allows use of four different types of mode switch. To select a mode switch, set bits C and D of memory switch Cn-01.

Cn-01 Bit C	Mode Switch Selection	Factory Setting: 0	For Speed Control and Position Control
Cn-01 Bit D	Mode Switch Selection	Factory Setting: 0	For Speed Control and Position Control

Use the following parameters to set the mode switch to be used.

Memory Switch Cn-01		Mode Switch Type	Parameter for Setting Detection Point
Bit D	Bit C		
0	0	Uses torque reference as a detection point.	Cn-0C
0	1	Uses speed reference as a detection point.	Cn-0D
1	0	Uses acceleration reference as a detection point.	Cn-0E
1	1	Uses error pulse as a detection point.	Cn-0F

Mode switch is used to reduce settling time and suppress undershoot when the motor stops. It switches PI control to P control when certain conditions are met.

3

Cn-0C	TRQMSW	Mode Switch (Torque Reference)	Unit: %	Setting Range: 0 to 800	Factory Setting: 200	For Speed Control and Position Control
Cn-0D	REFMSW	Mode Switch (Speed Reference)	Unit: min^{-1}	Setting Range: 0 to 10000	Factory Setting: 0	For Speed Control and Position Control
Cn-0E	ACCMSW	Mode Switch (Acceleration Reference)	Unit: $10 (\text{min}^{-1})/\text{s}$	Setting Range: 0 to 3000	Factory Setting: 0	For Speed Control and Position Control
Cn-0F	ERPMSW	Mode Switch (Error Pulse)	Unit: Reference Unit	Setting Range: 0 to 10000	Factory Setting: 10000	For Position Control Only

Mode switch is used to reduce settling time and suppress undershoot when the motor stops. It switches PI control to P control when certain conditions are met.

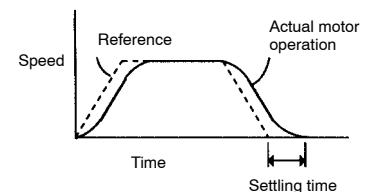

The SERVOPACK allows use of four different types of mode switch. To select a mode switch, set bits B, C and D of memory switch Cn-01.

3.6.6 Using Mode Switch cont.

Memory Switch Cn-01			Mode Switch Setting	Parameter	Unit
Bit D	Bit C	Bit B			
-	-	1	Does not use mode switch.		
0	0	0	Uses torque reference as a detection point.	Cn-0C	Percentage of rated torque: %
0	1	0	Uses speed reference as a detection point.	Cn-0D	Motor speed: min ⁻¹
1	0	0	Uses acceleration reference as a detection point.	Cn-0E	Motor acceleration: 10 (min ⁻¹)/s
1	1	0	Uses error pulse as a detection point.	Cn-0F	Reference unit

上正科技有限公司

購買、維修 此手冊零組件

電話： 037-466333

Email: service@repairtw.com

Line id: @zzzz

www.repairtw.com

3.7 Forming a Protective Sequence

This section describes how to use I/O signals from the SERVOPACK to form a protective sequence for safety purposes.

3.7.1 Using Servo Alarm Output and Alarm Code Output

Basic Wiring for Alarm Output Signals

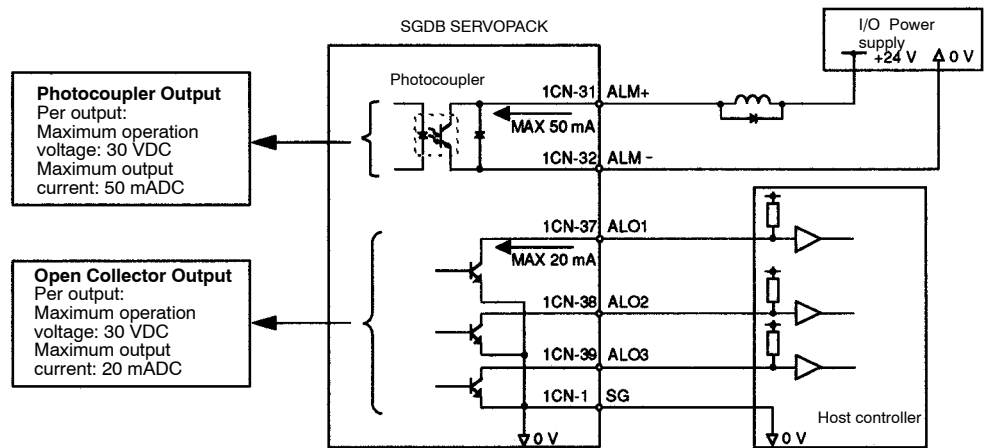

Provide an external I/O power supply separately. There is no DC power available from SERVOPACK for output signals.

Contact Output Signal ALM 037-466333

Output → ALM+ 1CN-31	Servo Alarm Output	For Speed/Torque Control and Position Control
Output → ALM- 1CN-32	Signal Ground for Servo Alarm Output	For Speed/Torque Control and Position Control

Signal ALM is output when the SERVOPACK detects an alarm.

Design the external circuit so that the main circuit power to the SGDB SERVOPACK is turned OFF by this alarm output signal.

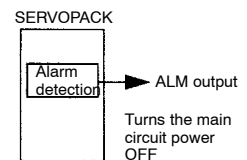

ON status:	Circuit between 1CN-31 and 1CN-32 is closed. 1CN-31 is at low level.	Normal state
OFF status:	Circuit between 1CN-31 and 1CN-32 is open. 1CN-31 is at high level.	Alarm state

Alarm codes ALO1, ALO2, and ALO3 are output to indicate each alarm type.

■ Open Collector Output Signals ALO1, ALO2, and ALO3

Output → ALO1 1CN-37	Alarm Code Output	For Speed/Torque Control and Position Control
Output → ALO2 1CN-38	Alarm Code Output	For Speed/Torque Control and Position Control
Output → ALO3 1CN-39	Alarm Code Output	For Speed/Torque Control and Position Control
Output → SG 1CN-1	Signal Ground for Alarm Code Output	For Speed/Torque Control and Position Control

These signals output an alarm code to indicate the type of an alarm detected by the SERVOPACK.

Use these signals to display alarm codes at the host controller.

3

上正科技有限公司

購買、維修 此手冊零組件

電話： 037-466333

Email: service@repairtw.com

Line id: @zzzz

www.repairtw.com

Relationship between Alarm Display and Alarm Code Output

Alarm Display and Alarm Code Output:

Alarm Display	Alarm Code Output			Servo Alarm (ALM) Output	Alarm Type	Alarm Description
	ALO1	ALO2	ALO3			
R0*	×	×	×	×	User constant error	An absolute encoder error occurred or parameter is faulty.
R10	○	×	×	×	Overcurrent	Overcurrent flowed through the main circuit. SERVOPACK overheated.
R3*	○	○	×	×	Regenerative error. Position error pulse overflow	Regenerative circuit is faulty. The number of pulses in error counter has exceeded the preset value.
R40	×	×	○	×	Main power voltage error	Main circuit DC voltage has exceeded approximately 420 V.
R51	○	×	○	×	Overspeed	Motor speed has exceeded the maximum allowable speed.
R7*	○	○	○	×	Overload	Motor and SERVOPACK are overloaded.
RC*	○	○	○	×	Overrun Disconnection of PG signal line	Overrun occurred due to motor or encoder signal wiring faults. Encoder signal line is disconnected.
R8*	×	×	×	×	Absolute encoder error	Absolute encoder is faulty.
RA1	○	○	○	×	Heatsink overheat	SERVOPACK heat sink overheated.
RA61	×	×	×	×	Reference input read error	Reference input failed to be detected.
RAF*	×	○	×	×	Power line open phase	One phase is missing from main circuit power supply.
CPF00	Undefined				Digital Operator transmission error	Communication error occurred between Digital Operator and SERVOPACK.
CPF01						
R99	×	×	×	○	No error	

○ : Output transistor is ON

×

* : Displays an alarm category number.

For details, refer to *Appendix D List of Alarm Displays*.

When the servo alarm (ALM) is output, eliminate the cause of the alarm and the turn ON the following /ALMRST input signal to reset the alarm state.

→ Input /ALMRST 1CN-44	Alarm Reset	For Speed/Torque Control and Position Control
------------------------	-------------	---

This signal is used to reset the servo alarm state.

Form an external circuit so that the main circuit power supply is turned OFF when servo alarm is output. Alarm state is automatically reset when control power supply is turned OFF.

Alarm state can be reset using the Digital Operator.

When an alarm occurs, always eliminate the cause before resetting the alarm state. 6.2.1 Troubleshooting Problems with Alarm Display describes how to troubleshoot the system when an alarm arises.

3.7.2 Using Servo ON Input Signal

This section describes how to wire and use contact input signal “servo ON (/S-ON).” Use this signal to forcibly turn the servomotor OFF from the host controller.

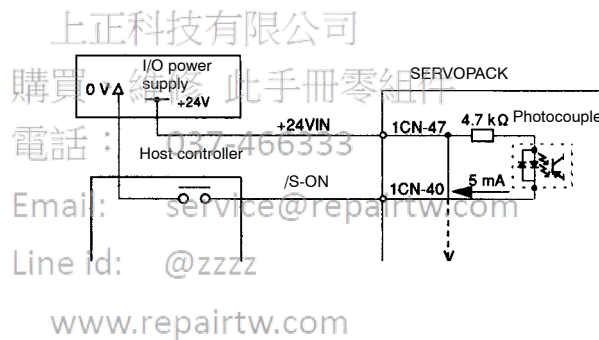

→ Input /S-ON 1CN-40	Servo ON	For Speed/Torque Control and Position Control
----------------------	----------	---

This signal is used to turn the motor ON or OFF.

ON: 1CN-40 is at low level	Turns the motor ON. This is normal operation state (called “servo ON state”).
OFF: 1CN-40 is at high level	Turns the motor OFF. This is inoperable state (called “servo OFF state”). The servo can be turned OFF during motor operation only when an emergency stop is required.

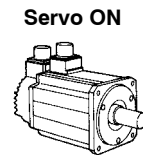

Servo ON
Motor is ON
Motor is operated according to input signals.

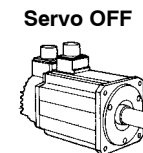

Servo OFF
Motor is OFF
Motor cannot run.

NOTE Do not use the /S-ON signal to start or stop the motor. Always use an input reference to start and stop the motor.

If the /S-ON signal is not to be used, set the following memory switch to 1:

Cn-01 Bit 0	Use of Servo ON Input Signal	Factory Setting: 0	For Speed/Torque Control and Position Control
--------------------	------------------------------	--------------------	---

This memory switch is used to enable or disable the servo ON input signal /S-ON (1CN-40).

When external short-circuit wiring is omitted, set the memory switch to "1."

SGDB SERVOPACK

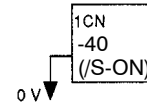

When /S-ON is not used, this short-circuit wiring can be omitted.

Setting	Meaning
0	Uses servo ON signal /S-ON. (When 1CN-40 is open, servo is OFF. When 1CN-40 is at 0 V, servo is ON.)
1	Does not use servo ON signal /S-ON. (Servo is always ON. Equivalent to short-circuiting 1CN-40 to 0 V.)

3

3.7.3 Using Positioning Complete Signal

This section describes how to wire and use contact output-signal "positioning complete output (/COIN)." This signal is output to indicate that servomotor operation is complete.

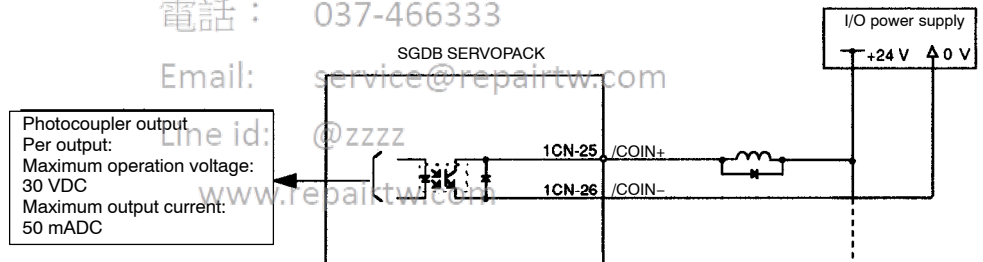

Output → /COIN 1CN-25	Positioning Complete Output	For Position Control Only
------------------------------	-----------------------------	---------------------------

This output signal indicates that motor operation is complete during position control. The host controller uses this signal as an interlock to confirm that positioning is complete.

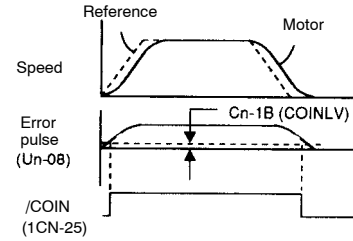

ON status:	Circuit between 1CN-25 and 1CN-26 is closed. 1CN-25 is at low level.	Positioning is complete (position error is below the preset value).
OFF status:	Circuit between 1CN-25 and 1CN-26 is open. 1CN-25 is at high level.	Preset value: Cn-1B (positioning complete range)

Preset Value: Cn-1B (positioning complete range)

Use the following parameter to output the /COIN signal.

Cn-2D	OUTSEL	Output signal selection	Setting Range: 110 to 666	Factory Setting: 210	
--------------	--------	-------------------------	---------------------------	----------------------	--

This parameter is used to specify a function signal as the 1CN output signal.

1s place	Select the 1CN-25 and 1CN-26 (/COIN, /V-CMP) functions.
10s place	Select the 1CN-27 and 1CN-28 (/TGON) functions.
100s place	Select the 1CN-29 and 1CN-30 (/S-RDY) functions.

Example: Outputting a /COIN signal
 Cn-2D=□□0
 (/COIN is output to 1CN-25 and 1CN-26 only.)

Preset Value	Function
0	/COIN, /V-CMP (Can be allocated to 1CN-25 and 1CN-26 only.)
1	/TGON
2	/S-RDY
3	/CLT
4	/BK
5	Overload warning
6	Overload alarm

Set the number of error pulses in the following parameter to adjust output timing of COIN (positioning complete output).

Cn-1B	COINLV	Positioning Complete Range	Unit: Reference Unit	Setting Range: 0 to 250	Factory Setting: 1	For Position Control Only
--------------	--------	----------------------------	----------------------	-------------------------	--------------------	---------------------------

This parameter is used to set output timing of positioning complete signal (/COIN, 1CN-25) to be output when motor operation is complete after a position reference pulse has been input.

Set the number of error pulses in terms of reference unit (the number of input pulses that is defined using the electronic gear function).

If too large a value is set in this parameter, error may become too small when the motor runs at a low speed, causing COIN to be output continuously.

COINLV does not affect the final positioning accuracy.

NOTE /COIN is a signal for position control. For speed control, /V-CMP (speed coincidence output) is used instead. For torque control, /COIN is always ON.

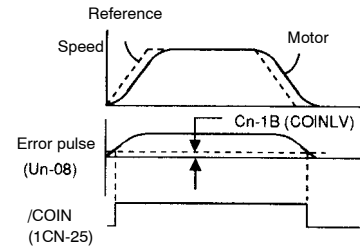

上正科技有限公司

購買、維修 此手冊零組件

電話： 037-466333

Email: service@repairtw.com

Line id: @zzzz

www.repairtw.com

3.7.4 Using Speed Coincidence Output Signal

This section describes how to wire and use contact output signal “speed coincidence output (/V-CMP).” This signal is output to indicate that actual motor speed matches a reference speed. The host controller uses this signal as an interlock.

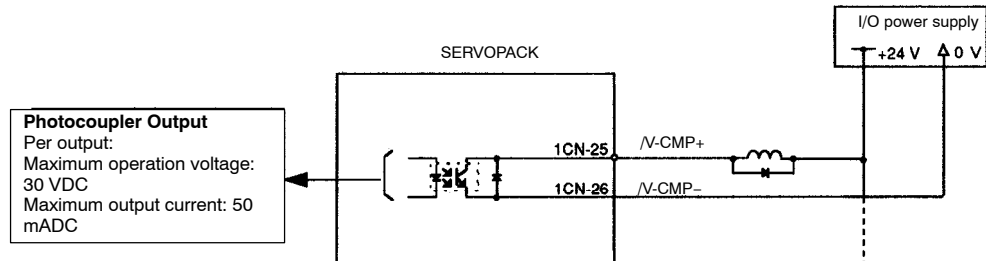

3

Output → /V-CMP 1CN-25	Speed Coincidence Output	For Speed Control Only
-------------------------------	--------------------------	------------------------

This output signal indicates that actual motor speed matches the input speed reference during speed control.

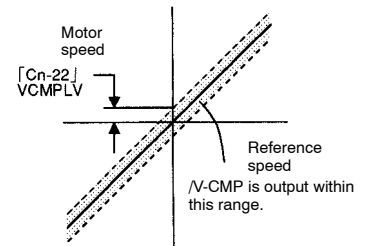

上正科技有限公司
購買、維修 此手冊零組件

ON status:	Circuit between 1CN-25 and 1CN-26 is closed. 1CN-25 is at low level.	Actual motor speed matches the speed reference (speed difference is below the preset value).
OFF status:	Circuit between 1CN-25 and 1CN-26 is open. 1CN-25 is at high level.	Actual motor speed does not match the speed reference (speed difference is greater than the preset value).

Preset value: Cn-22 (speed coincidence signal output width)

Use the following parameter to output the /V-CMP signal.

Cn-2D	OUTSEL	Output signal selection	Setting Range: 110 to 666	Factory Setting: 210
--------------	--------	-------------------------	---------------------------	----------------------

This parameter is used to specify a function signal as the 1CN output signal.

1s place	Select the 1CN-25 and 1CN-26 (/COIN, /V-CMP) functions.
10s place	Select the 1CN-27 and 1CN-28 (TGON) functions.
100s place	Select the 1CN-29 and 1CN-30 (/S-RDY) functions.

Example: Outputting a /V-CMP signal

Cn-2D=□□0

(/V-CMP is output to 1CN-25 and 1CN-26 only.)

Preset Value	Function
0	/COIN, /V-CMP (Can be allocated to 1CN-25 and 1CN-26 only.)
1	/TGON
2	/S-RDY
3	/CLT
4	/BK
5	Overload warning
6	Overload alarm

Set the following parameter to specify the output conditions for speed coincidence signal /V-CMP.

Cn-22	VCMPPLV	Speed Coincidence Signal Output Width	Unit: min ⁻¹	Setting Range: 0 to 100	Factory Setting: 10	For Speed Control Only

Set the output conditions for speed coincidence signal /V-CMP (1CN-25).

/V-CMP signal is output when the difference between the reference speed and actual motor speed is not greater than the preset value.

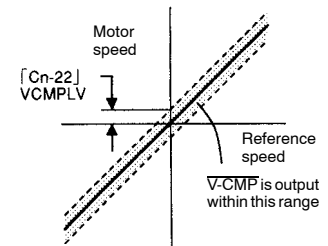

Email: service@repairtw.com

Example: When preset value is 100 and reference speed is 2000 min⁻¹.

/V-CMP is ON (circuit between 1CN-25 and 1CN-26 is closed) when the speed is between 1900 and 2100 min⁻¹.

NOTE /V-CMP is a signal for speed control.
For position control, /COIN (position complete output) is used instead. For torque control, /V-CMP is always ON.

3.7.5 Using Running Output Signal

This section describes how to wire and use photocoupler output: a running output signal /TGON. This signal indicates that a servomotor is currently running.

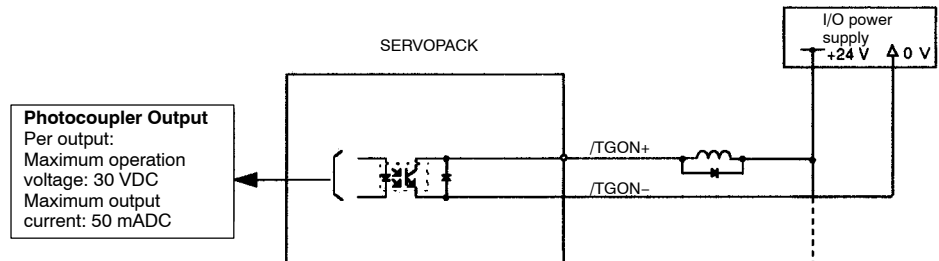

3

Output → /TGON	Running Output	For Speed/Torque Control and Position Control
-----------------------	----------------	---

This output signal indicates that the motor is currently running.

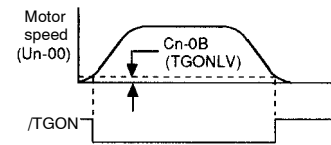

It is used as an external interlock.

ON status:	Circuit is closed or signal is at low level.	Motor is running. (Motor speed is greater than the preset value.)
OFF status:	Circuit is open or signal is at high level.	Motor is stopped. (Motor speed is below the preset value.)

Preset value: Cn-0B (zero-speed level)

Use the following parameter to specify the pin to which the /TGON signal is to be output.

Cn-2D	OUTSEL	Output signal selection	Setting Range: 110 to 666	Factory Setting: 210	
--------------	--------	-------------------------	---------------------------	----------------------	--

This parameter is used to specify a function signal as the 1CN output signal.

1s place	Select the 1CN-25 and 1CN-26 (/COIN, /V-CMP) functions.
10s place	Select the 1CN-27 and 1CN-28 (/TGON) functions.
100s place	Select the 1CN-29 and 1CN-30 (/S-RDY) functions.

Example: /TGON is output to 1CN-27 and 1CN-28.

Cn-2D=1

Preset value	Function
0	/COIN, /V-CMP (Can be allocated to 1CN-25 and 1CN-26 only.)
1	/TGON
2	/S-RDY
3	/CLT
4	/BK
5	Overload warning
6	Overload alarm

Use the following parameter to specify the output conditions for /TGON (running output signal).

Cn-0B	TGONLV	Zero-Speed Level	Unit: min ⁻¹	Setting Range: 1 to 10000	Factory Setting: 20	For Speed/Torque Control and Position Control

3

This parameter is used to set the speed level at which the SERVOPACK determines that the motor is running and then outputs a signal.

The following signals are output when motor speed exceeds the preset value. (The circuit is closed when motor speed exceeds the preset value.)

- /TGON
- Status indication mode bit data
- Monitor mode Un-05 bit 4

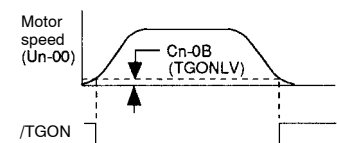

上正科技有限公司
 購買、維修 此手冊零組件
 電話： 037-466333
 Email: service@repairtw.com
 Line id: @zzzz
 www.repairtw.com

3.7.6 Using OL Warning and Alarm Output Signals

This section describes how to wire and use photocoupler output signals OLWRN (overload warning) and OL (overload alarm).

These two output signals are output when operation under the rated current or more continues for a certain period of time. The overload warning signal is output in 20% of the time required to output the overload alarm signal.

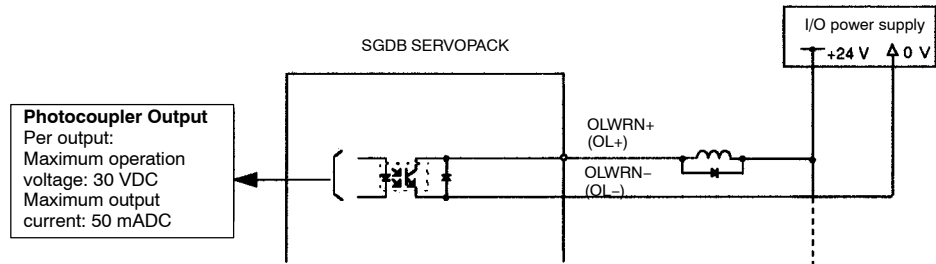
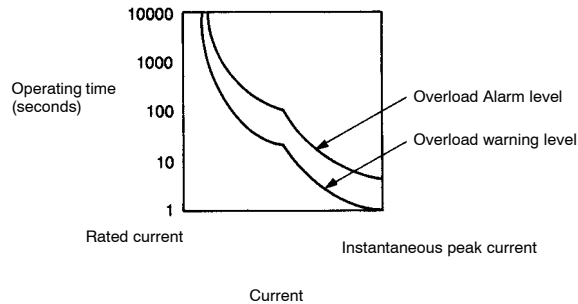

上正科技有限公司

Output → /OLWRN	Overload Warning Output	For Speed/Torque Control and Position Control
Output → OL	Overload Alarm Output	For Speed/Torque Control and Position Control

Line id: @zzzz

OLWRN is an overload warning output signal, and OL is an overload alarm output signal.

ON status:	Circuit is closed or signal is at low level.	Normal state
OFF status:	Circuit is open or signal is at high level.	Warning or alarm state

Use the following parameter to specify the pin to which the signal is to be output.

Cn-2D	OUTSEL	Output signal selection	Setting Range: 110 to 666	Factory Setting: 210	For Speed/Torque Control and Position Control
--------------	--------	-------------------------	---------------------------	----------------------	---

This parameter is used to specify a function signal as the 1CN output signal.

1s place	Select the 1CN-25 and 1CN-26 (/COIN, /V-CMP) functions.
10s place	Select the 1CN-27 and 1CN-28 (/TGON) functions.
100s place	Select the 1CN-29 and 1CN-30 (/S-RDY) functions.

Example: Overload warning is output to 1CN-27 and 1CN-28.

Cn-2D=□5□

Preset Value	Function
0	/COIN, /V-CMP (Can be allocated to 1CN-25 and 1CN-26 only.)
1	/TGON
2	/S-RDY
3	/CLT
4	/BK
5	Overload warning
6	Overload alarm

3

上正科技有限公司

購買、維修 此手冊零組件

電話： 037-466333

Email: service@repairtw.com

Line id: @zzzz

www.repairtw.com

3.7.7 Using Servo Ready Output Signal

This section describes how to wire and use photocoupler output signal /S-RDY (servo ready).

“Servo ready” means that the SERVOPACK is not in servo alarm state when the main circuit is turned ON. For absolute encoder specifications, “servo ready” means that, in addition to the above, the SEN signal is at high level and the absolute encoder is also in ready state.

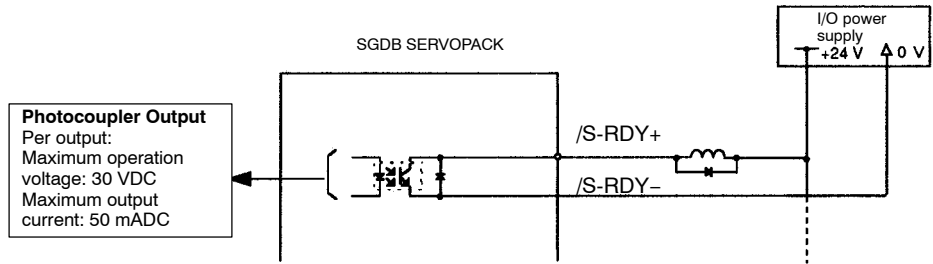

3

Output → /S-RDY	Servo Ready Output	For Speed/Torque Control and Position Control
------------------------	--------------------	---

This signal indicates that the SERVOPACK is ready to receive servo ON signals.

ON status:	Circuit is closed or signal is at low level.	Servo ready state
OFF status:	Circuit is open or signal is at high level.	Not in servo ready state

Use the following parameter to specify the pin to which the /S-RDY signal is to be output.

Cn-2D	OUTSEL Output signal selection	Setting Range: 110 to 666	Factory Setting: 210	For Speed/Torque Control and Position Control
--------------	--------------------------------	---------------------------	----------------------	---

This parameter is used to specify a function signal as the 1CN output signal.

1s place	Select the 1CN-25 and 1CN-26 (/COIN, /V-CMP) functions.
10s place	Select the 1CN-27 and 1CN-28 (/TGON) functions.
100s place	Select the 1CN-29 and 1CN-30 (/S-RDY) functions.

Example: /S-RDY is output to 1CN-29 and 1CN-30.

Cn-2D=2□□

Preset Value	Function
0	/COIN, /V-CMP (Can be allocated to 1CN-25 and 1CN-26 only.)
1	/TGON
2	/S-RDY
3	/CLT
4	/BK
5	Overload warning
6	Overload alarm

3.7.8 Handling of Power Loss

Use the following memory switch to specify whether to output a servo alarm when power loss occurs.

Cn-01 Bit 5	Operation to Be Performed at Recovery from Power Loss	Factory Setting: 0	For Speed/Torque Control and Position Control
-------------	---	--------------------	---

If the SGDB SERVOPACK detects instantaneous voltage drop in power supply, it can output servo alarm A.F3 to prevent a hazardous situation. This memory switch is used to specify whether to output this alarm.

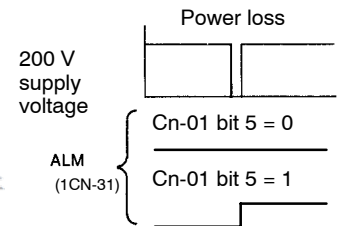

Setting	Meaning
0	Does not output a servo alarm after recovery from power loss.
1	Outputs a servo alarm after recovery from power loss.

Normally, set this memory switch to 0. If the /S-RDY signal is not to be used, set the memory switch to 1. The /S-RDY signal remains OFF while the main power supply is OFF, regardless of the memory switch setting.

3.8 Special Wiring

This section describes special wiring methods including the one for noise control. Always refer to *Section 3.8.1 Wiring Instructions* and *3.8.2 Wiring for Noise Control*, and refer to other sections as necessary.

3.8.1 Wiring Instructions

To ensure safe and stable operation, always refer to the following wiring instructions.

NOTE Always use the following cables for reference input and encoder wiring.

	Cable Type	Yaskawa Drawing No.	Maximum Allowable Length
For reference input	Twisted-pair cables	DE9406969	3 m (9.8 ft.)
For encoder	Multiconductor shielded twisted-pair cable	B9400064 (for incremental encoder) DP8409123 (for absolute encoder)	20 m (65.6 ft.)

NOTE For a ground wire, use as thick a cable as possible.



- Trim off the excess portion of the cable to minimize the cable length.
- At least class 3 grounding (ground to 100 Ω or less) is recommended.
- Always use one-line grounding.
- If the motor is insulated from the machine, ground the motor directly.
- Select grounding phase and grounding point in accordance with the national code and consistent with sound local practices.

NOTE Do not bend or apply tension to cables.

- Since the conductor of a signal cable is very thin (0.2 to 0.3 mm), handle it with adequate care.

NOTE Use a noise filter to prevent noise interference.
(For details, refer to the following *Caution*.)

- If the servo is to be used near private houses or may receive noise interference, install a noise filter on the input side of the power supply line. Since this SERVOPACK is designed as an industrial device, it provides no mechanism to prevent noise interference.

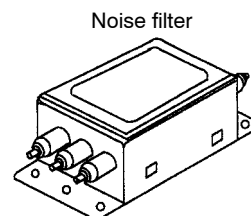

NOTE To prevent malfunction due to noise, take the following actions:

- Position the input reference device and noise filter as close to the SERVOPACK as possible.
- Always install a surge absorber circuit in the relay, solenoid and magnetic contactor coils.
- The distance between a power line (such as a power supply line or motor cable) and a signal line must be at least 30 cm (12 in). Do not put the power and signal lines in the same duct or bundle them together.
- Do not share the power supply with an electric welder or electrical discharge machine. When the SERVOPACK is placed near a high-frequency oscillator, install a noise filter on the input side of the power supply line.

Note a) Since SERVOPACK uses high-speed switching elements, signal lines may receive noise. To prevent this, always take the above actions.

b) For details of grounding and noise filters, refer to *Section 3.8.2 Wiring for Noise Control*.

NOTE Use a molded-case circuit breaker (MCCB) or fuse to protect the power supply line from high voltage.

- This SERVOPACK is directly connected to commercial power supply without a transformer. Always use an MCCB or fuse to protect the servo system from accidental high voltage.
- Select an appropriate MCCB or fuse according to the SERVOPACK capacity and the number of SERVOPACKs to be used as shown below.

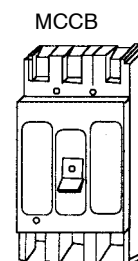

MCCB or Fuse for Each Power Capacity

SERVOPACK Type	Power Capacity Per SERVOPACK (kVA) (see note 1)	Current Capacity Per MCCB or Fuse (A) (see note 2)
SGDB-03AD□	0.65	5
SGDB-05AD□	1.1	
SGDB-07AD□	1.5	
SGDB-10AD□	2.0	8
SGDB-15AD□	2.5	
SGDB-20AD□	4.0	10
SGDB-30AD□	5.0	12
SGDB-44AD□	7.0	18
SGDB-50AD□	7.5	24
SGDB-60AD□	12.5	28
SGDB-75AD□	15.0	32
SGDB-1AAD□	19.0	41
SGDB-1EAD□	30.0	60
		80

- Note**
- 1) Power capacity at rated load
 - 2) Operating characteristics (25°C): 2 seconds or more for 200%, 0.01 second or more for 700%
 - 3) A fast-operating fuse cannot be used because the SERVOPACK power supply is a capacitor input type. A fast-operating fuse may blow out when the power is turned ON.

上正科技有限公司

購買、維修 此手冊零組件

電話： 037-466333

Email: service@repairtw.com

Line id: @zzzz

3.8.2 Wiring for Noise Control

■ Example of Wiring for Noise Control

This SERVOPACK uses high-speed switching elements in the main circuit. It may receive “switching noise” from these high-speed switching elements if wiring or grounding around the SERVOPACK is not appropriate. To prevent this, always wire and ground the SERVOPACK correctly.

This SERVOPACK has a built-in microprocessor (CPU). To protect the microprocessor from external noise, install a noise filter in place.

The following is an example of wiring for noise control.

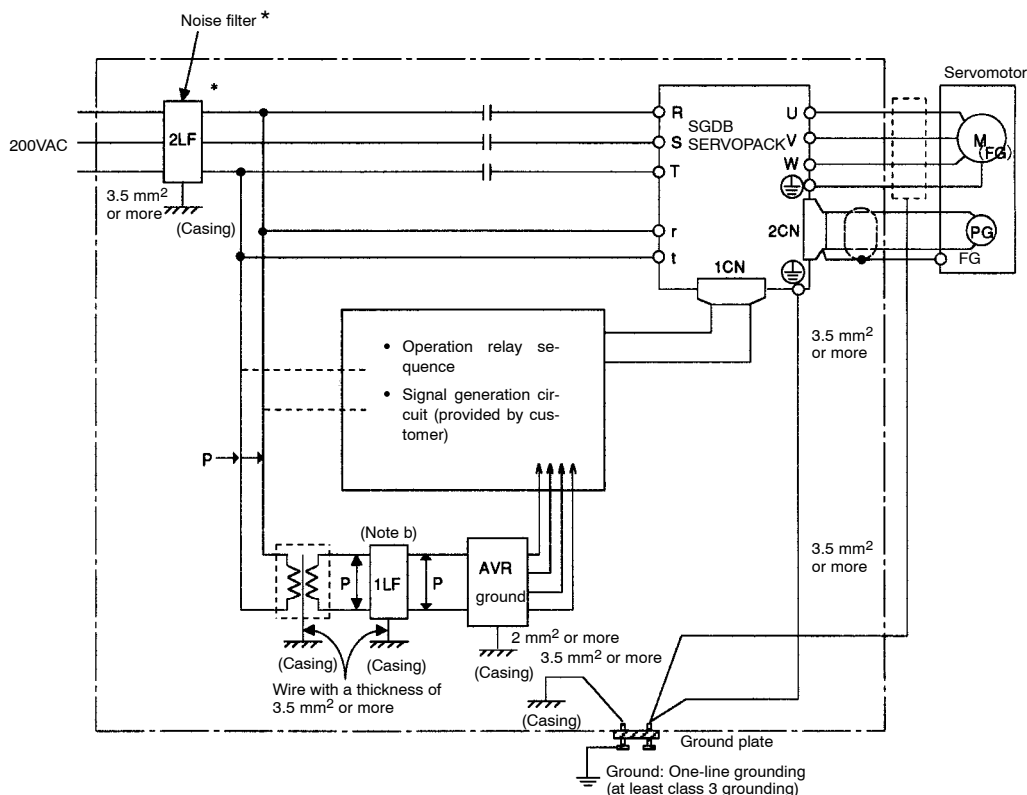

* When using a noise filter, always observe the following wiring instructions:

- Note**
- a) For a ground wire to be connected to the casing, use a thick wire with a thickness of at least 3.5 mm² (preferably, plain stitch cooper wire).
 - b) For wires indicated by P↑, use twisted-pair cables whenever possible.

■ Correct Grounding

- Always ground the motor frame.

Always connect servomotor frame terminal FG to the SERVOPACK ground terminal (⊕).
Be sure to ground the ground terminal (⊕).

- If the servomotor is grounded via the machine, a switching noise current will flow from the SERVOPACK power unit through motor stray capacitance. The above grounding is required to prevent the adverse effects of switching noise.
- If the reference input line receives noise, do the following.

Ground the 0 V line (SG) of the reference input line. If the main circuit wiring for the motor is accommodated in a metal conduit, ground the conduit and its junction box. For all grounding, always use one-line grounding.

■ Noise Filter Installation

Use an inhibit type noise filter to prevent noise from the power supply line.

Install a noise filter on the power supply line for peripheral equipment as necessary.

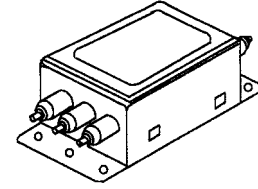

The following table lists recommended noise filters for each SERVOPACK type.

Noise Filter Types

SERVOPACK Type		Noise Filter Connection	Recommended Noise Filter	
			Type	Specifications
0.3 kW	SGDB-03AD□	<p>(Correct)</p> <p>(Incorrect)</p>	LF-310	Three-phase 200 VAC, 10 A
0.5 kW	SGDB-05AD□		LF-315	Three-phase 200 VAC, 15 A
0.7 kW	SGDB-07AD□		LF-320	Three-phase 200 VAC, 20 A
1.0 kW	SGDB-10AD□		LF-330	Three-phase 200 VAC, 30 A
1.5 kW	SGDB-15AD□		LF-340	Three-phase 200 VAC, 40 A
2.0 kW	SGDB-20AD□		LF-350	Three-phase 200 VAC, 50 A
3.0 kW	SGDB-30AD□		LF-360	Three-phase 200 VAC, 60 A
4.4 kW	SGDB-44AD□		LF-380K	Three-phase 200 VAC, 80 A
5.0 kW	SGDB-50AD□		FN-258-100 (Manufactured by Shaffner)	Three-phase 200 VAC, 100 A
6.0 kW	SGDB-60AD□			
7.5 kW	SGDB-75AD□			
11.0 kW	SGDB-1AAD□			
15.0 kW	SGDB-1EAD□			

Note These noise filters are manufactured by Tokin Corp. and available from Yaskawa. For noise filters, contact your nearest Yaskawa sales representatives.

Always observe the following installation and wiring instructions. Incorrect use of a noise filter halves its benefits.

- Separate input lines from output lines.

Do not put the input and output lines in the same duct or bundle them together.

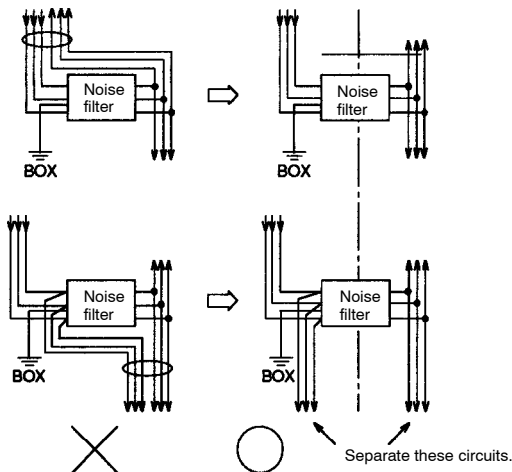
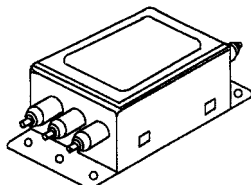

- Separate the noise filter ground wire from the output lines.

Do not accommodate the noise filter ground wire, output lines and other signal lines in the same duct or bundle them together.

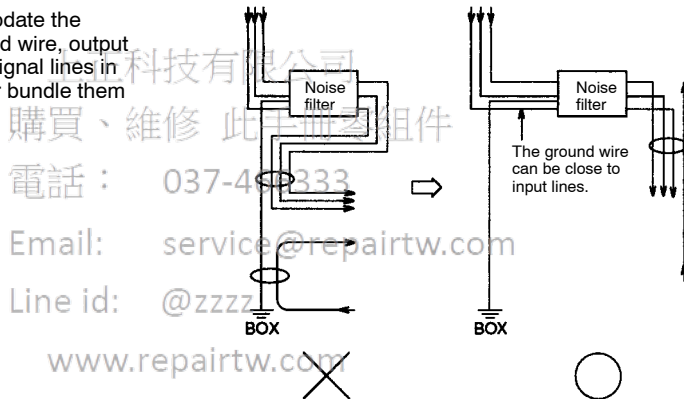

科技有限公司
 購買、維修 此手冊之組件
 電話： 037-400333
 Email: service@repairtw.com
 Line id: @zzzz
 www.repairtw.com

- Connect the noise filter ground wire directly to the ground plate.

Do not connect the noise filter ground wire to other ground wires.

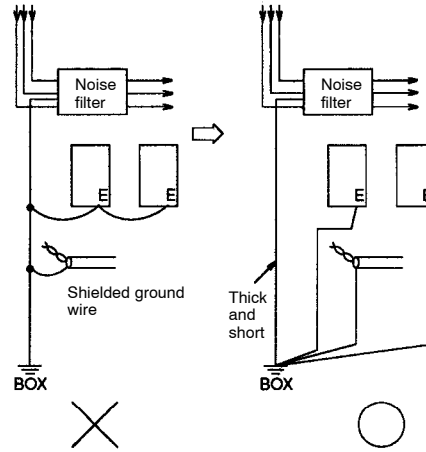

3

- When grounding a noise filter inside a Unit.

If a noise filter is located inside a Unit, connect the noise filter ground wire and the ground wires from other devices inside the Unit to the ground plate for the Unit first, then ground these wires.

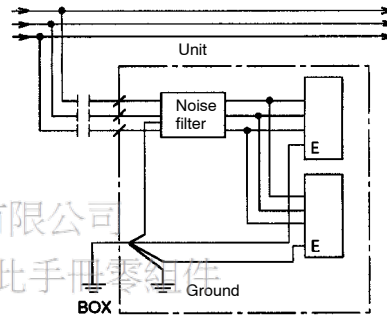

上正科技有限公司

購買、維修 此手冊零組件

電話： 037-466333

Email: service@repairtw.com

Line id: @zzzz

www.repairtw.com

3.8.3 Using More Than One Servo Drive

■ Example of Wiring More than One Servo Drive

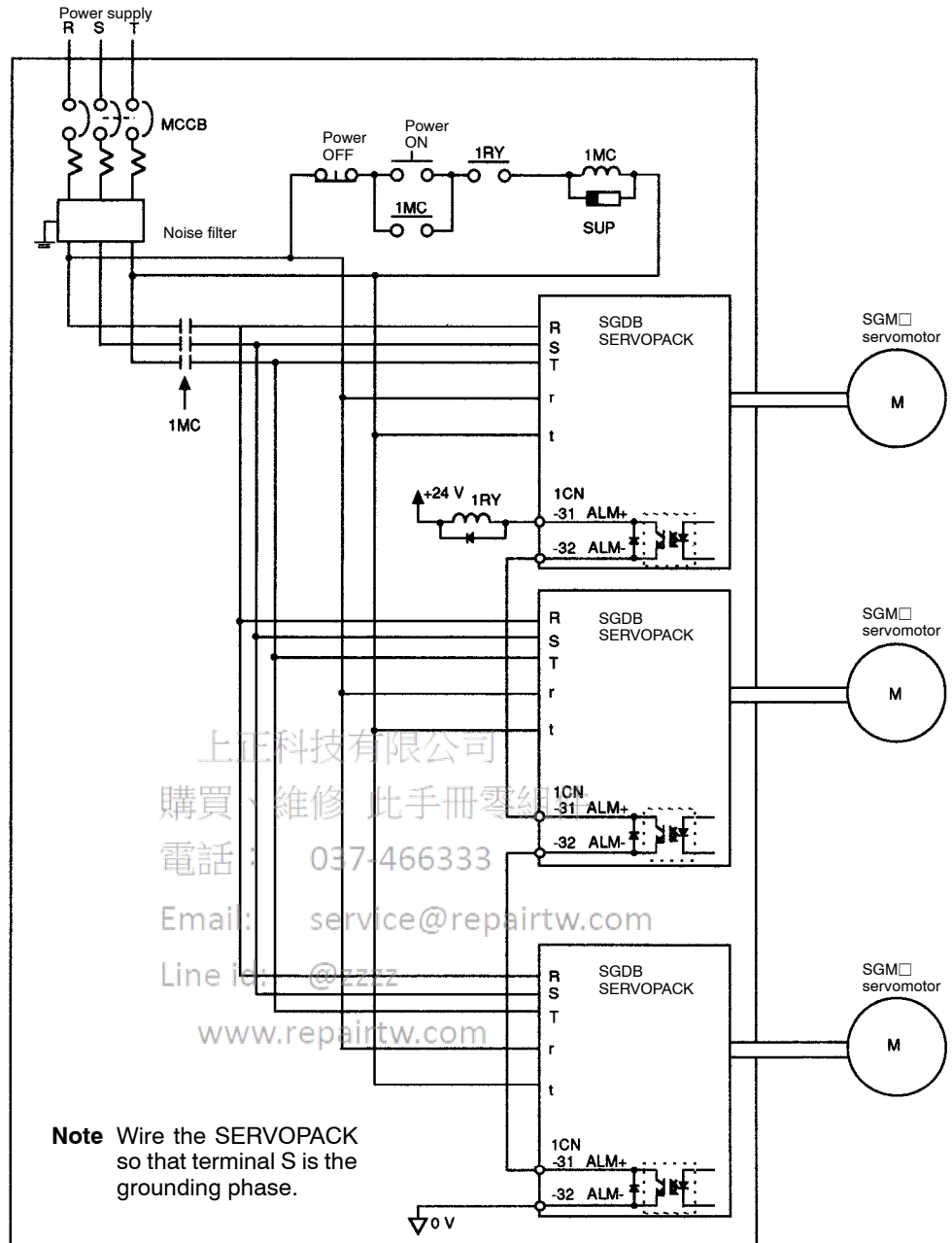

3

Connect the alarm output (ALM) terminals for the three SERVOPACKs in series to enable alarm detection relay 1RY to operate. This is because ALM is a logical complement output signal, so the output transistor is turned OFF when the system enters an alarm state.

The output transistor is turned OFF when the ALM output signal invokes alarm state.

APPLICATIONS OF Σ -SERIES PRODUCTS

3.8.3 Using More Than One Servo Drive cont.

Multiple servos can share a single MCCB or noise filter. Always select a MCCB or noise filter that has enough capacity for the total power capacity (load conditions) of those servos. For details, refer to page 144.

MCCB

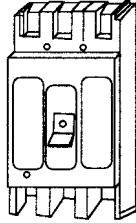

Noise filter

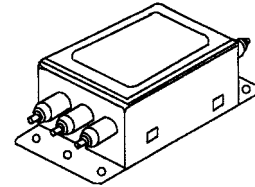

Noise Filter Types

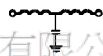
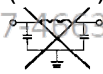
SERVOPACK Type		Noise Filter Connection	Recommended Noise Filter	
			Type	Specifications
0.3 kW	SGDB-03AD□	<p>(Correct)</p>  <p>(Incorrect)</p> 	LF-310	Three-phase 200 VAC, 10 A
0.5 kW	SGDB-05AD□		LF-315	Three-phase 200 VAC, 15 A
0.7 kW	SGDB-07AD□		LF-320	Three-phase 200 VAC, 20 A
1.0 kW	SGDB-10AD□		LF-330	Three-phase 200 VAC, 30 A
1.5 kW	SGDB-15AD□		LF-340	Three-phase 200 VAC, 40 A
2.0 kW	SGDB-20AD□		LF-350	Three-phase 200 VAC, 50 A
3.0 kW	SGDB-30AD□		LF-360	Three-phase 200 VAC, 60 A
4.4 kW	SGDB-44AD□		LF-380K	Three-phase 200 VAC, 80 A
5.0 kW	SGDB-50AD□		FN-258-100 (Manufactured by Shaffner)	Three-phase 200 VAC, 100 A
6.0 kW	SGDB-60AD□			
7.5 kW	SGDB-75AD□			
11.0 kW	SGDB-1AAD□			
15.0 kW	SGDB-1EAD□			

Note These noise filters are manufactured by Tokin Corp. and available from Yaskawa. For noise filters, contact your nearest Yaskawa sales representatives.

3.8.4 Using Regenerative Resistor Units

SERVOPACKs of 6.0 kW or higher have no built-in regenerative resistor. For such SERVOPACKs, connect an external regenerative resistor unit.

■ Connecting a Regenerative Resistor Unit

The standard connection diagram for a regenerative resistor unit is shown below.

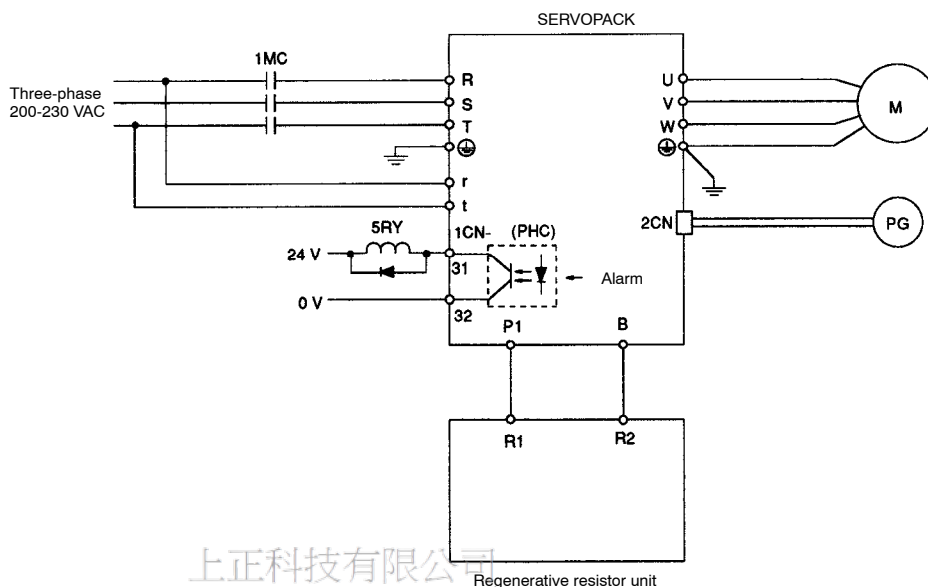

上正科技有限公司
購買、維修 此手冊零組件
電話： 037-466333

Email: service@repairtw.com
Line id: @zzzz

■ Regenerative Resistor Units

SERVOPACK Type	Regenerative Resistor Unit Type	Regenerative Resistance (Ω)
SGDB-60AD□	JUSP-RA04	6.25
SGDB-75AD□	JUSP-RA05	3.13
SGDB-1AAD□		
SGDB-1EAD□		

NOTE A regenerative resistor unit becomes very hot under some regenerative operation conditions of the servo system. Therefore, provide a cooling mechanism for the regenerative resistor unit, use heat resistant and incombustible cables, and route the cables so that they are not in contact with the unit.

The resistor specifications of each regenerative resistor unit are as follows:

JUSP-RA04 Type: 25Ω (220 W) x 4 (connected in parallel)

JUSP-RA05 Type: 25Ω (220 W) x 8 (connected in parallel)

A regenerative resistor reaches approximately 90°C when it is used at 20% of the rated allowable dissipation value of the resistor. The allowable motor regenerative power (average) is 180 W for the JUSP-RA04 Type, and 350 W for the JUSP-RA05 Type. If the regenerative power (average) exceeds the allowable limit value when the servo system is operating in regenerative operation mode, select an additional regenerative resistor that has a greater rated allowable dissipation value (W). Therefore, always take the servo system operation conditions into consideration when determining which regenerative resistor unit to use.

Example of allowable motor duty conditions

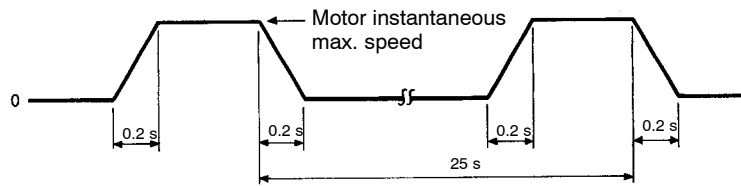

- Motor deceleration torque: Maximum torque
 - Load inertia: Five times the motor rotor inertia
- Assuming that there is no mechanical loss.

3.8.5 Using an Absolute Encoder

■ Outline

An absolute value detection system detects an absolute position of the machine even when the servo system is OFF. If such a system is to be formed in the host controller, use an SGM□ servomotor with absolute encoder. Consequently, automatic operation can be performed without zero return operation immediately after the power is turned ON.

SGM□-□□□W□ 12-bit absolute encoder
 SGM□-□□□S□ 15-bit absolute encoder

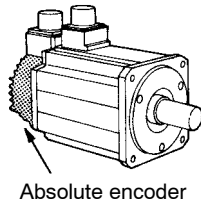

Always detects absolute position



~~Zero return operation~~

■ Standard Connection Diagram for an Absolute Encoder Mounted on a Servomotor

• Interface Circuit

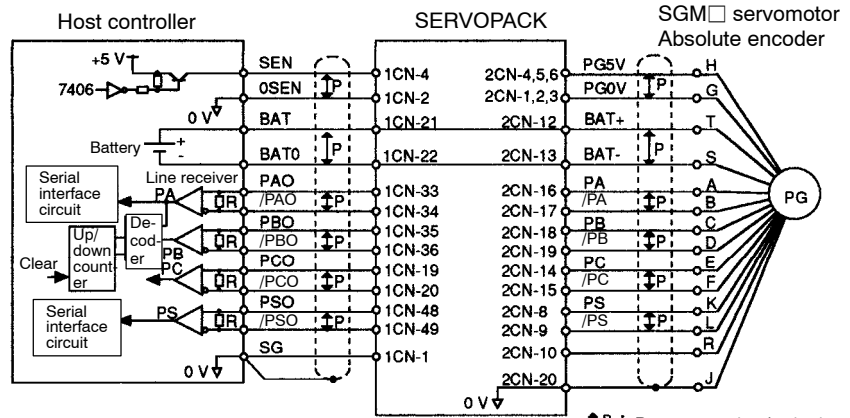

Line Receiver Used: SN75175 or MC3486 manufactured by Texas Instruments Inc.
 Termination Resistor R: 220 to 470 Ω

⚡ P : Represents twisted pair wires

PS, /PS, PSO and /PSO are for 12-bit absolute encoders only.

SEN signal

- If turning ON the power of the control circuit for the SERVOPACK, set the level of the SEN signal to low.
- The SEN signal must be set at high level after at least three seconds after the power is turned ON.
- When the SEN signal is changed from low level to high level, +5 V is applied to the absolute encoder, and serial data and initial incremental pulses are transmitted.
- The motor is not turned ON until these operations are complete, regardless of the servo ON signal (/S-ON).

Electrical Specifications

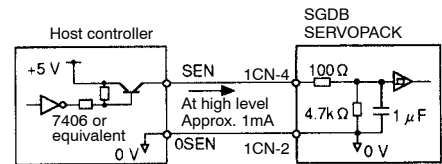

- A PNP transistor is recommended.
- Signal level High level: Min. 2.5 V
Low level: Max. 0.8 V

■ Memory Switch to Determine Whether to Use Input Signal SEN

Cn-01 Bit 1	Use of SEN Input Signal	Factory Setting: 0	For Speed/Torque Control and Position Control
--------------------	-------------------------	--------------------	---

This memory switch is used to determine whether to use input signal SEN (1CN-4). This memory switch is available for absolute encoders only (not for incremental encoders).

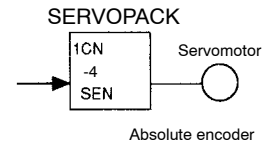

Setting	Meaning
0	Uses SEN signal.
1	Does not use SEN signal. (The SGDB SERVOPACK always assumes that the SEN signal is at high level, regardless of the actual signal level.)

NOTE If the SEN signal is to be turned OFF, then ON again, it must remain at high level for at least 1.3 seconds before being turned OFF.

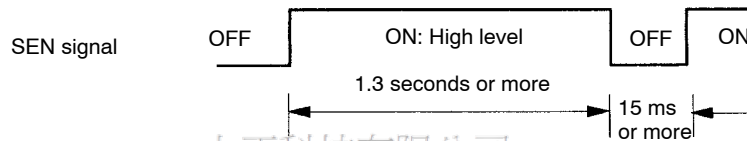

■ Memory Switch to Select Absolute Encoder

Cn-01 Bit E	Encoder Type Selection	Factory Setting: 0	For Speed/Torque Control and Position Control
--------------------	------------------------	--------------------	---

Sets the encoder type according to the servomotor type to be used.

After changing the memory switch setting, turn the power OFF, then ON.

Motor Type encoder specifications	Number of Encoder Pulses Per Revolution	Preset Value
2	Incremental encoder: 8192 pulses per revolution	0
3	Incremental encoder: 2048 pulses per revolution	
6	Incremental encoder: 4096 pulses per revolution	
W	Absolute encoder: 1024 pulses per revolution	1
S	Absolute encoder: 8192 pulses per revolution	

Use the following parameter to set the number of pulses for the absolute encoder to be used:

Cn-11	PULSNO Number of Encoder Pulses	Unit: P/R	Setting Range: Number of Encoder Pulses	For Speed/Torque Control and Position Control
--------------	------------------------------------	--------------	--	---

Sets the number of encoder pulses according to the servomotor type to be used.

After changing the memory switch setting, turn the power OFF, then ON.

Motor Type encoder specifications	Number of Encoder Pulses Per Revolution	Preset Value
2	Incremental encoder: 8192 pulses per revolution	8192
3	Incremental encoder: 2048 pulses per revolution	2048
6	Incremental encoder: 4096 pulses per revolution	4096
W	Absolute encoder: 1024 pulses per revolution	1024
S	Absolute encoder: 8192 pulses per revolution	8192

3

NOTE Incorrect settings of the above parameters may result in abnormal motor operation. To prevent this, always set the parameter correctly.

■ Using a Battery

Use the following battery to enable the absolute encoder to store position information even when the power is turned OFF. Load the battery in the host controller and connect it to SERVOPACK input terminals BAT and BAT0.

Recommended battery:	<ul style="list-style-type: none"> Connect the battery securely to prevent contact faults resulting from environmental changes or aging. Battery voltage is not monitored inside the SERVOPACK. Provide a battery voltage monitor circuit as necessary.
Lithium battery	
Toshiba Battery ER6V C3 Type 3.6 V, 2000 mAH	Minimum voltage: 2.8 V

■ Setting up Absolute Encoder

Set up the absolute encoder in the following cases:

- When starting the machine for the first time
- When the absolute encoder is not connected to power supply or backup power supply (battery) for more than two days

The setup procedure is as follows:

15-bit absolute encoder (Motor type encoder specifications=S)

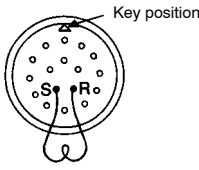
1	Discharging Electricity from the Encoder
<ul style="list-style-type: none"> • Turn the SGDB SERVOPACK OFF, then disconnect the encoder connector. • Short-circuit encoder connector terminals R and S for at least two minutes. 	
	

2	Turning Power ON
<ul style="list-style-type: none"> • Return the wiring to the normal state. • Connect the battery, turn the SGDB SERVOPACK ON, and set the SEN signal at high level. • If alarm "A.00" arises, repeat the same procedure from the beginning. • If no problem has occurred, the setup procedure is complete. 	

3

12-bit absolute encoder (Motor type encoder specifications=W)

1	Turning SGDB SERVOPACK ON
<ul style="list-style-type: none"> • Wire the SGDB SERVOPACK, motor and encoder in the normal way. • Connect the battery and turn the SGDB SERVOPACK ON. 	

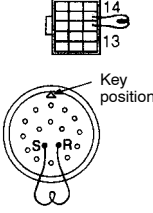
3	Resetting Data
<ul style="list-style-type: none"> • Turn the SGDB SERVOPACK OFF, then disconnect the encoder connector. • Short-circuit encoder connector terminals 13 and 14 for two seconds or more. (For SGM and SGMP servomotors) • Short-circuit encoder connector terminals R and S for at least two seconds. (For SGMG, SGMD, and SGMS servomotors) 	
	

2	Turning the Encoder ON
<ul style="list-style-type: none"> • Set the SEN signal at high level. • Keep the encoder turned ON for at least three minutes. • It does not matter even if alarm status arises. 	

4	Turning the Power ON
<ul style="list-style-type: none"> • Return the wiring to the original state. • Turn the SGDB SERVOPACK ON and set the SEN signal at high level. • If alarm "A.00" arises, repeat the same procedure from the beginning. • If no problem has occurred, the setup procedure is complete. 	

NOTE Setting up the encoder sets the revolution count inside the encoder to 0. After setting up the encoder, always reset the machine home position. Operating the machine without the home position being reset does not only damage the machine but may also cause an accident resulting in injury or death.

■ Absolute Data Exchange Sequence

The SERVOPACK sends absolute data to the host controller when receiving output from an absolute encoder. This data exchange sequence is described below.

Use the following detailed information when designing a host controller.

Outline of Absolute Signal

The absolute encoder outputs PAO, PBO, PCO and PSO as shown on the right.

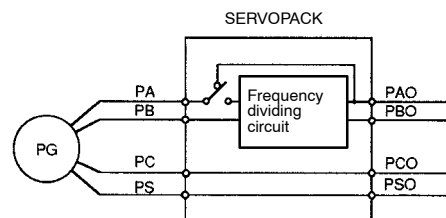

Signal Name	Status	Contents
PAO	Initial state	Serial data Initial incremental pulse
	Normal state	Incremental pulse
PBO	Initial state	Initial incremental pulse
	Normal state	Incremental pulse
PCO	Normal state	Home position pulse
PSO	Normal state	Rotation count serial data (12-bit absolute encoder only)

3

Contents of Absolute Data

Serial Data: Indicates how many turns the motor shaft has made from the reference position (position specified at setup).

Initial Incremental Pulse: Outputs pulses at the same pulse rate as when the motor shaft rotates from the home position to the current position at the maximum speed of 4,900 min⁻¹.

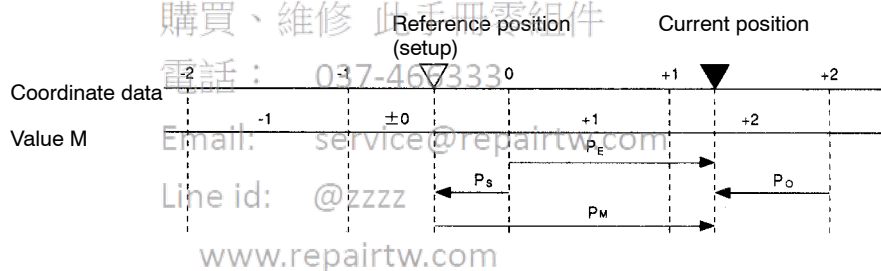

Absolute data P_M can be determined using the following formula.

$$P_E = M \times R + P_o$$

$$P_M = P_E - P_s$$

P_E	Current value read by encoder
M	Serial data (rotation count data)
P_o	Number of initial incremental pulses (Normally, this is a negative value)
P_s	Number of initial incremental pulses read at setup (Normally, this is a negative value stored and controlled by a host controller.)
P_M	Current value required for the customer system
R	Number of pulses per encoder revolution (pulse count after dividing, value of Cn-0A)

Absolute Data Transmitting Sequence

1. Set the SEN signal at high level.
2. After 100 ms, set the system to serial data reception-waiting-state. Clear the incremental pulse up/down counter to zero.
3. Receive eight bytes of serial data.
4. The system enters a normal incremental operation state approximately 50 ms after the last serial data is received.

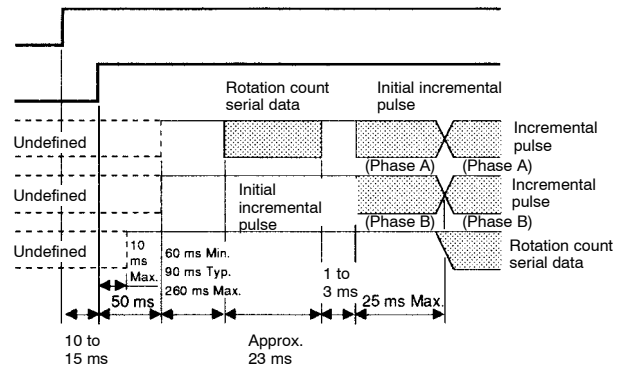

Detailed Specifications of Each Signal

• Specifications of PAO Serial Data:

The number of revolutions is output in five digits.

Data transmission method	Start-stop synchronization (ASYNC)
Baud rate	9600
Start bit	1 bit
Stop bit	1 bit
Parity	Even number
Character code	ASCII 7-bit code
Data format	8 characters. As shown on the right.

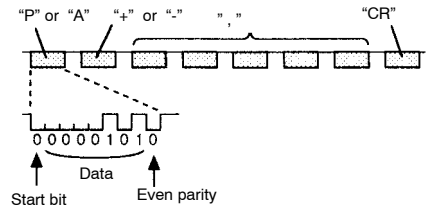

- Data is P+0000 (CR) or P-0000 (CR) when the number of revolutions is zero.
- The maximum number of revolutions is ±99999. If this value is exceeded, it returns to 0000.

• Specifications of PSO Serial Data:

The number of revolutions and the absolute position within one revolution are always output in five and four digits, respectively. The transmission cycle is approximately 40 ms.

Data transmission method	Start-stop synchronization (ASYNC)
Baud rate	9600
Start bit	1 bit
Stop bit	1 bit
Parity	Even number
Character code	ASCII 7-bit code
Data format	13 characters. As shown on the right.

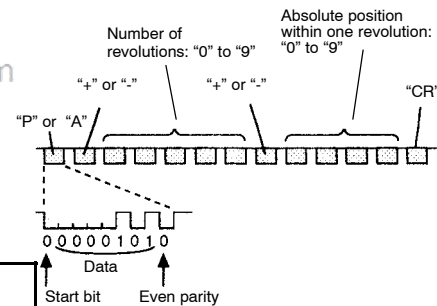

- Absolute position data within one revolution is a value before frequency dividing. (4,096 pulses per revolution)
- Absolute position data increases during forward rotation (standard setting). (Not valid in reverse rotation mode)

- Incremental Pulse and Home Position Pulse:

Initial incremental pulses which provide absolute data are first divided by the frequency divider inside the SERVOPACK and then output in the same way as normal incremental pulses.

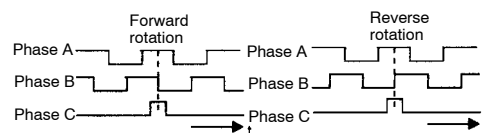

- Note that phase C is not divided so its pulse width is narrower than phase A.

- Use the following parameter to set the pulse dividing ratio.

Cn-0A	PGRAT Dividing Ratio Setting	Unit: P/R	Setting Range: 16 to Number of Encoder Pulses		For Speed/Torque Control and Position Control
--------------	------------------------------------	-----------	--	--	---

Set the number of output pulses for PG output signals (PAO, /PAO, PBO and /PBO).

Pulses from motor encoder (PG) are divided by the preset number of pulses before being output.

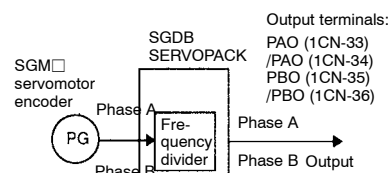

The number of output pulses per revolution is set in this parameter. Set this value according to the reference unit of the machine or controller to be used.

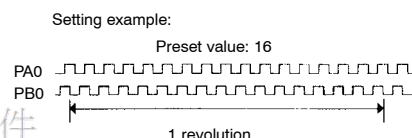

The setting range varies according to the encoder used.

電話： 037-466333
 Email: service@repairtw.com
 Line id: @zzzz
 www.repairtw.com

■ Alarm Display

When a 12-bit absolute encoder is used, the following alarms are detected and displayed.

List of Alarms

Alarm Type	Meaning	Digital Operator Display	PAO Serial Data	PSO Serial Data
Backup Alarm	Indicates that backup voltage drop was detected. (This alarm helps maintain reliability of rotation count data.)		ALM81. (CR)	ALARMOA BACK (CR)
Battery Alarm	Indicates that backup voltage drop was detected. (This alarm warns of battery replacement and disconnection.)		ALM83. (CR)	ALARMOD BATT (CR)
Checksum Error	Indicates that an error was detected in memory data check.		ALM82. (CR)	ALARMOB CHEC (CR)
Overspeed	Indicates that the motor was running at a speed exceeding 400 min ⁻¹ when the encoder was turned ON.		ALM85. (CR)	ALARMOP OVER (CR)
Absolute Error	Indicates that an error was detected in sensor check inside the encoder.		ALM84. (CR)	ALARMOH ABSO (CR)
Backup/Battery Combination Alarm			ALM81. (CR)	ALARMOE BACK (BATT) (CR)

Line id: @zzzz

The SEN signal can be used to output alarm information from PAO and PSO as serial data.

SEN Signal	“L”:			
	“H” Error detection “H”		“L”	“L”
Digital Operator Display		 Absolute encoder alarm (Details unknown)	 Absolute encoder alarm (Alarm type identified)	
PAO Serial Data	 Incremental pulse	ALM80. (CR)	ALARMO* (CR)	ALM8*. (CR)
PSO Serial Data	P±□□□□□, □□□□ (CR)	H±□□□□□, □□□□ (CR) and so on	(Undefined)	ALARMO* **** (CR)

■ Absolute Encoder Home Position Error Detection

Cn-02 Bit 1	Absolute Encoder Home Position Error Detection	Factory Setting: 0	For Speed/Torque Control and Position Control
--------------------	--	--------------------	---

This memory switch is used to specify whether to use **home position error detection** (alarm A.80) when an absolute encoder is used.

Setting	Meaning
0	Detects a home position error.
1	Does not detect a home position error.

Normally, set this memory switch to “0”.

This memory switch has no significance when an incremental encoder is used.

上正科技有限公司

購買、維修 此手冊零組件

電話： 037-466333

Email: service@repairtw.com

Line id: @zzzz

www.repairtw.com



Home position error detection

This function detects an encoder count error resulting from noise. It checks the number of pulses per motor revolution, and outputs a home position error alarm if that number is incorrect.

If the absolute encoder detects an error, it inverts phase C and notifies the SERVOPACK of the error. In this case, this “home position error detection” function also works.

3.8.6 Extending an Encoder Cable

Both incremental and absolute encoders have a standard encoder cable (maximum 20 meters (65.6 ft.)). If a longer cable is required, prepare an extension cable as described below. The maximum allowable cable length is 50 meters (164 ft.).

- 3-meter (19.8 ft.) Cable with Connectors (for SGM and SGMP)

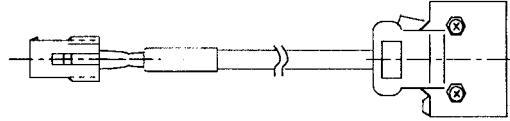

- For incremental encoder: DP9320089-1
- For absolute encoder: DP9320088-1

- 3-meter (1.98 ft) Cable with Connector

- Encoder Plug and Cable Clamp (for SGMG, SGMD, and SGMS)

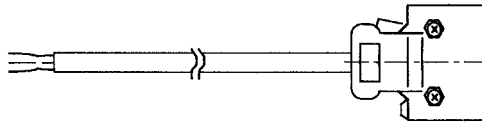

上正科技有限公司

購買、維修 此手冊零組件

電話： 037-466333

- For incremental encoder: DE9406971-1
- For absolute encoder: DE9406972-1

- L-type plug: MS3108B20-29S@zzzz

or

- Straight plug: MS3106B20-29S

- Cable clamp: MS3057-12A

www.repairtw.com

■ 50-meter (164 ft.) Extension Cable

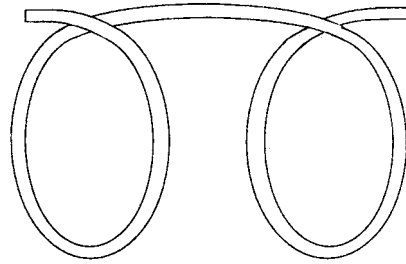

- For both incremental and absolute encoders: DP8409179

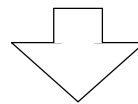

Cut this cable 30 cm (0.98 ft.) or less from each end.

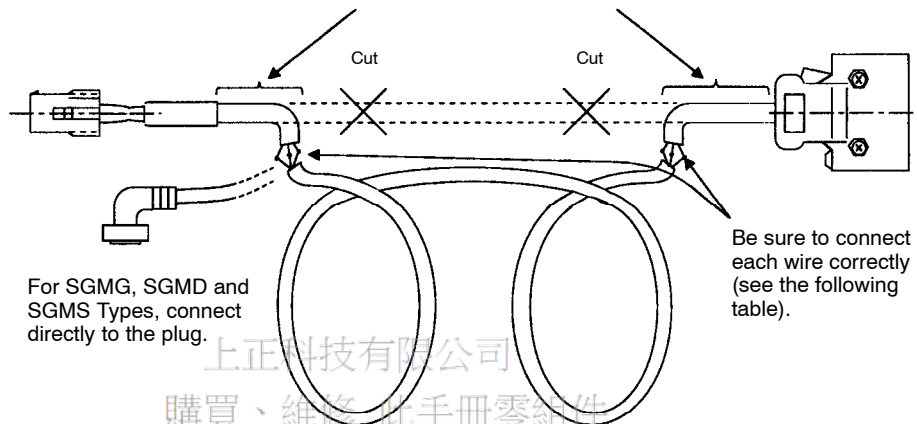

For SGMG, SGMD and SGMS Types, connect directly to the plug.

Be sure to connect each wire correctly (see the following table).

上正科技有限公司

購買、維修 此手冊零組件

電話： 037-466333

Email: service@repairtw.com

Line id: @zzzz

www.repairtw.com

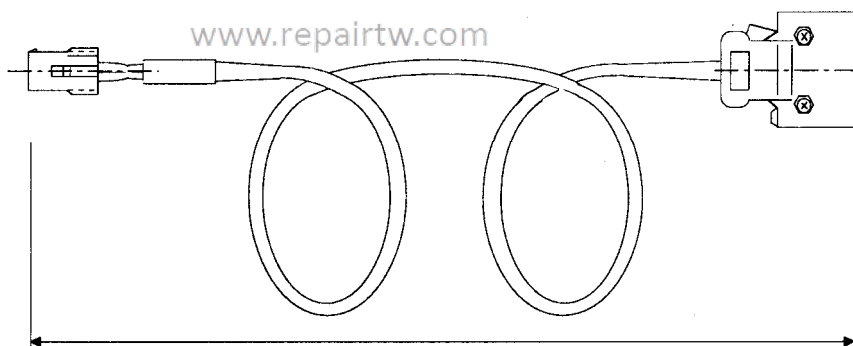

Maximum 50 m (164 ft.)

3

Connect cables of the same color to each other as shown in the table below. Note that wiring for incremental and absolute encoders is different.

Signal Name	Color and Wire Size of Cable with Connectors		Color and Wire Size of 50-meter Extension Cable (DP8409179)	
PG5V	Red	AWG22	Red	AWG16
PG0V	Black	AWG22	Black	AWG16
PA	Blue	AWG26	Blue	AWG26
*PA	White/Blue	AWG26	White/Blue	AWG26
PB	Yellow	AWG26	Yellow	AWG26
*PB	White/Yellow	AWG26	White/Yellow	AWG26
PC	Green	AWG26	Green	AWG26
*PC	White/Green	AWG26	White/Green	AWG26
PS	Purple	AWG26	Purple	AWG26
*PS	White/Green	AWG26	White/Green	AWG26
RESET	White/Gray	AWG26	White/Gray	AWG26
BAT	Orange	AWG26	Orange	AWG26
BAT0	White/Orange	AWG26	White/Orange	AWG26

Only the absolute encoder can be connected.

Note Make sure to connect the shielded wires.

3.8.7 Using SGDB SERVOPACK with High Voltage Line

SGDB SERVOPACKs use three-phase 200 VAC.

If, however, three-phase 400 VAC class (400 V, 440 V) power supply must be used, prepare the following power transformer (for three-phase).

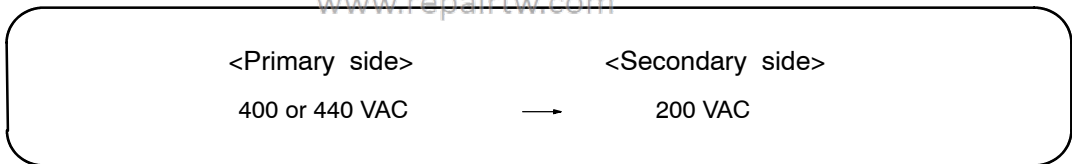

Select appropriate power transformer capacity according to the following table.

SERVOPACK Type	Power Supply Capacity Per SGDA SERVOPACK (kVA) (see note)
SGDB-03AD□	0.65
SGDB-05AD□	1.1
SGDB-07AD□	1.5
SGDB-10AD□	2.0
SGDB-15AD□	2.5
SGDB-20AD□	4.0
SGDB-30AD□	5.0
SGDB-44AD□	7.0
SGDB-50AD□	7.5
SGDB-60AD□	12.5
SGDB-75AD□	15.0
SGDB-1AAD□	19.0
SGDB-1EAD□	30.0

Note At rated load.

When 400-V-class supply voltage is used, power must be turned ON and OFF on the primary side of the power transformer.

上正科技有限公司

購買、維修 此手冊零組件

電話： 037-466333

Email: service@repairtw.com

Line id: @zzzz

www.repairtw.com

3.8.8 Connector Terminal Layouts

This section describes connector terminal layouts for SERVOPACKs, SGM servomotors and Digital Operators.

■ SERVOPACK Connectors

1CN Terminal Layout

1	SG	0V	26	/V-CMP (/COIN-)	Speed coincidence output
2	SG	0V	27	/TGON+	TGON output signal
3	PL1	Power supply for open collector reference	28	/TGON-	TGON output signal
4	SEN	SEN signal input	29	/S-RDY+	Servo ready output
5	V-REF	Speed reference input	30	/S-RDY-	Servo ready output
6	SG	0V	31	/ALM+	Servo alarm output
7	PULS	Reference pulse input	32	ALM-	Servo alarm output
8	/PULS	Reference pulse input	33	PAO	PG dividing output phase A
9	T-REF	Torque reference input	34	/PAO	PG dividing output phase A
10	SG	0V	35	PBO	PG dividing output phase B
11	SIGN	Reference sign input	36	/PBO	PG dividing output phase B
12	/SIGN	Reference sign input	37	ALO1	Alarm code output (open collector output)
13	PL2	Power supply for open collector reference	38	ALO2	
14	/CLR	Error counter clear input	39	ALO3	
15	CLR	Error counter clear input	40	/S-ON	Servo ON input
16	TQR-M	Torque monitor	41	/P-CON	P control input
17	VTG-M	Speed monitor	42	P-OT	Forward over-travel input
18	PL3	Power supply for open collector reference	43	/N-OT	Reverse over-travel input
19	PCO	PG dividing output phase C	44	/ALM-RST	Alarm reset input
20	/PCO	PG dividing output phase C	45	/P-CL	Forward external torque limit ON input
21	BAT	Battery (+)	46	/N-CL	Reverse external torque limit ON input
22	BAT0	Battery (-)	47	+24V IN	External power supply input
23	+12V	Power supply for speed/torque reference	48	PSO	Phase S Signal output
24	-12V	Power supply for speed/torque reference	49	/PSO	Phase S Signal output
25	/V-CMP (/COIN+)	Speed coincidence signal output	50	FG	Frame ground

- **SERVOPACK Side** Connector type: 10250-52A2JL (manufactured by 3M)
- **Cable Side** Connector type: 10150-3000VE (manufactured by 3M)
Connector case type: 10350-52A0-008 (manufactured by 3M)

2CN Terminal Layout

2	PG0V	PG power supply 0 V	1	PG0V	PG power supply 0 V	12	BAT +	Battery (+) (for absolute encoder only)	11		
4	PG5V	PG power supply +5 V	3	PG0V	PG power supply 0 V	14	PC	PG input phase C	13	BAT -	Battery (-) (for absolute encoder only)
6	PG5V		5	PG5V		PG power supply +5 V	16	PA	PG input phase A	15	/PC
8	PS	PG input phase S (for absolute encoder only)	7	DIR	Rotation direction input	18	PB	PG input phase B	17	/PA	PG input phase A
10			9	PS	PG input phase S (for absolute encoder only)	20	FG	Frame ground	19	/PB	PG input phase B

- **SERVOPACK Side** Connector type: 10220-52A2JL (manufactured by 3M)
- **Cable Side** Connector type: 10120-3000VE (manufactured by 3M)
Connector case type: 10320-52A0-008 (manufactured by 3M)

■ Connectors for Incremental Encoder

[SGM and SGMP series]

1	Channel A output	Blue
2	Channel /A output	Blue/Black
3	Channel B output	Yellow
4	Channel /B output	Yellow/Black
5	Channel C output	Green
6	Channel /C output	Green/Black
7	0 V (power supply)	Gray
8	+5 V (power supply)	Red
9	Frame ground (FG)	Orange



Items to be Prepared by Customer
Cap: 172161-1
Socket: 170361-1 (chain type) or 170365-1 (loose type)

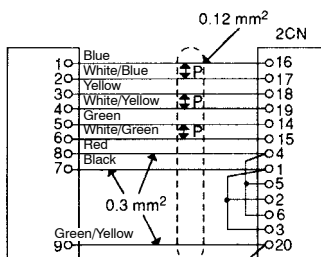
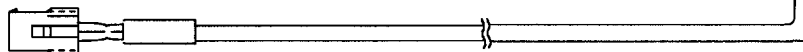
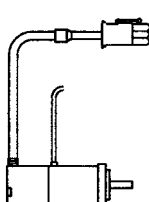
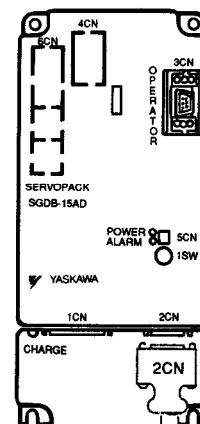

Items to be Prepared by Customer
Case: 10320-52A0-008 (manufactured by 3M)
Connector: 10120-3000VE (manufactured by 3M)

■ Connectors for Absolute Encoder
[SGM and SGMP series]

1	Channel A output	Blue
2	Channel /A output	White/Blue
3	Channel B output	Yellow
4	Channel /B output	White/Yellow
5	Channel Z output	Green
6	Channel /Z output	White/Green
7	0 V (power supply)	Black
8	+5 V (power supply)	Red
9	Frame ground (FG)	Green/Yellow
10	Channel S output	Purple
11	Channel /S output	White/Purple
12	(Capacitor reset)	(Gray)
13	Reset	White/Gray
14	0 V (battery)	White/Orange
15	3.6 V (battery)	Orange

Do not use this terminal. (It is used to discharge electricity from capacitor before shipment.)

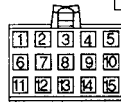

Items to be Prepared by Customer
Cap: 172163-1
Socket: 170361-1 (chain type) or
170365-1 (loose type)

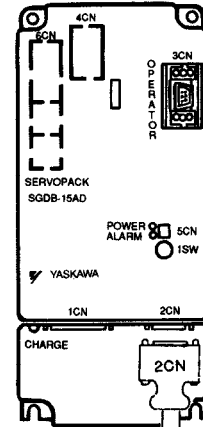

上正科技有限公司
購買、維修 此手冊零組件
電話: 037-465333
Email: service@repairtv.com
Line id: 7777
www.repairtv.com

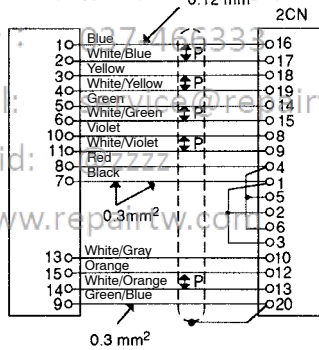

Items to be Prepared by Customer
Case: 10320-52A0-008
(manufactured by 3M)
Connector: 10120-3000VE
(manufactured by 3M)

3

■ Connectors for Incremental Encoder
[SGMG, SGMD and SGMS series]

A	Channel A output
B	Channel /A output
C	Channel B output
D	Channel /B output
E	Channel C output
F	Channel /C output
G	0 V (power supply)
H	+5 V (power supply)
J	Frame ground (FG)

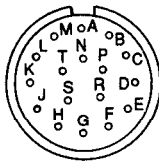

Items to be Prepared by Customer
 Plug: (L shaped) MS3108B20-29S or
 (Straight) MS3106B20-29S
 Cable clamp: MS3057-12A

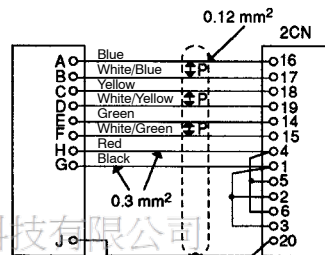
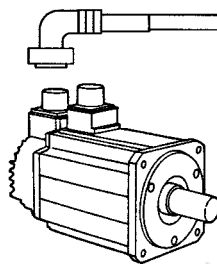
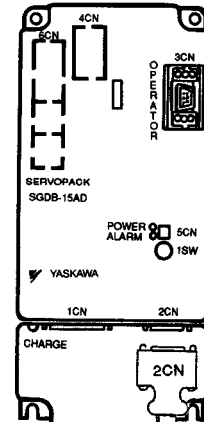

Items to be Prepared by Customer
 Case: 10320-52A0-008
 (manufactured by 3M)
 Connector: 10120-3000VE
 (manufactured by 3M)

上正科技有限公司

購買、維修 此手冊零組件

電話： 037-466333

Email: service@repairtw.com

Line id: @zzzz

www.repairtw.com

■ Connectors for Absolute Encoder

[SGMG, SGMD and SGMS series]

A	Channel A output
B	Channel /A output
C	Channel B output
D	Channel /B output
E	Channel Z output
F	Channel /Z output
G	0 V (power supply)
H	+5 V (power supply)
J	Frame ground (FG)
K	Channel S output
L	Channel /S output
R	Reset
S	0 V (battery)
T	3.6 V (battery)

Items to be Prepared by Customer
 Plug: (L shaped) MS3108B20-29S or
 (Straight) MS3106B20-29S
 Cable clamp: MS3057-12A

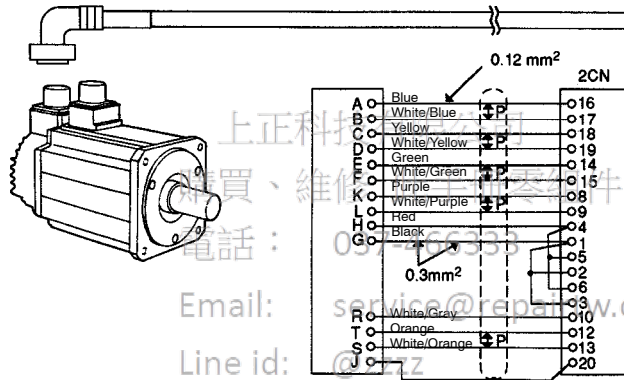
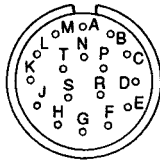
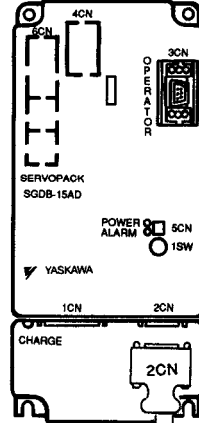

Items to be Prepared by Customer

Case:
 10320-52A0-008
 (manufactured by 3M)
 Connector:
 10120-3000VE
 (manufactured by 3M)

上正科技
 購買、維修、零件
 電話：09-2653333
 Email: service@repairtw.com
 Line id: @szk

www.repairtw.com

■ Connectors and Terminals for Standard-type Motor without Brake
[SGM and SGMP series]

1	Phase U	Red
2	Phase V	White
3	Phase W	Blue
4	Frame ground (FG)	Green

For SGMP-15A

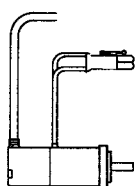
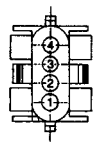

Cap: 172159-1
Socket: 170362-1 or 170366-1

For SGMP-15A
Cap: 350780-1
Socket: 350536-6 or 350550-6

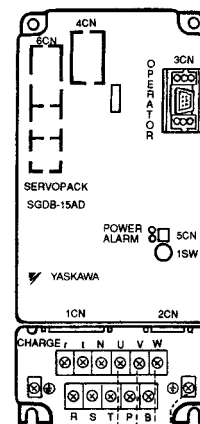

M4 crimp terminal

Items to be Prepared by Customer
Round crimp terminal R1.25-4TOR
(manufactured by AMP.)

3

上正科技有限公司

購買、維修 此手冊零組件

電話： 037-466333

Email: service@repairtw.com

Line id: @zzzz

www.repairtw.com

■ Connectors and Terminals for Motor with Brake
[SGM and SGMP series]

1	Phase U	Red
2	Phase V	White
3	Phase W	Blue
4	Frame ground (FG)	Green
5	Brake terminal	Black
6	Brake terminal	Black

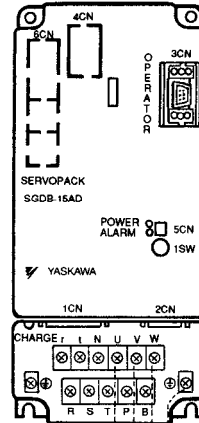

For SGMP-15A

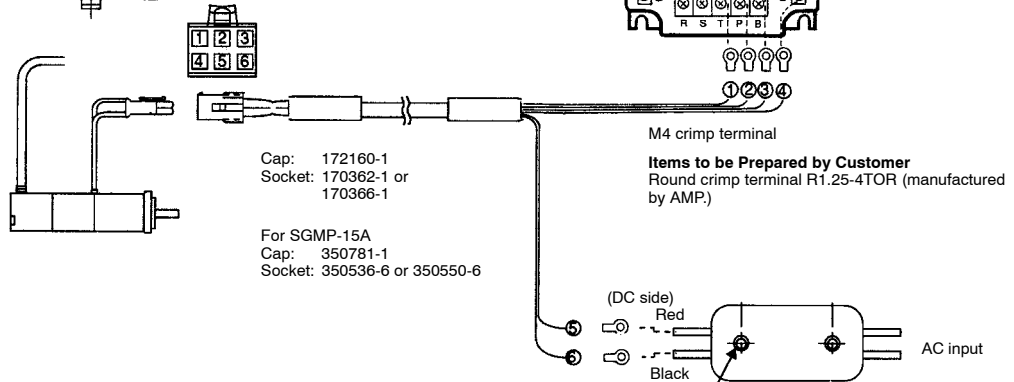
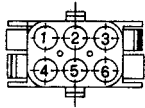

Cap: 172160-1
Socket: 170362-1 or 170366-1

For SGMP-15A
Cap: 350781-1
Socket: 350536-6 or 350550-6

M4 crimp terminal

Items to be Prepared by Customer
Round crimp terminal R1.25-4TOR (manufactured by AMP)

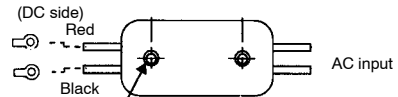

Brake power supply (manufactured by Yaskawa Controls Co., Ltd.)

- 100 VAC input: 90 VDC (LPDE-1H01)
- 200 VAC input: 90 VDC (LPSE-2H01)

上正科技有限公司

購買、維修 此手冊零件

電話： 037-466333

Email: service@repairtw.com

Line id: @zzzz

www.repairtw.com

■ Connectors and Terminals for Standard-type Motor without Brake
[SGMG, SGMD and SGMS series]

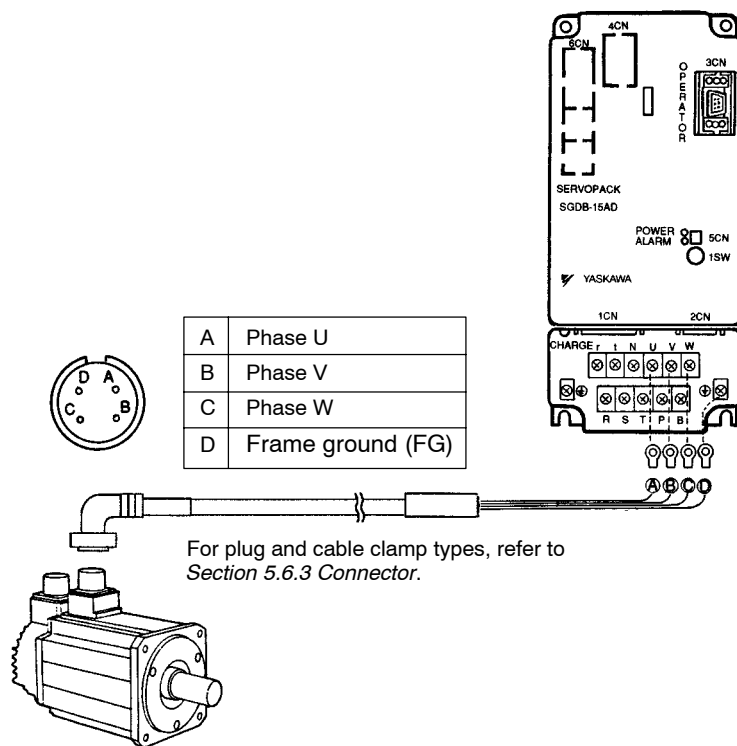

3

上正科技有限公司

購買、維修 此手冊零組件

電話： 037-466333

Email: service@repairtw.com

Line id: @zzzz

www.repairtw.com

■ Connectors and Terminals for Motor with Brake
[SGMG, SGMD and SGMS series]

A	Phase U
B	Phase V
C	Phase W
D	Frame ground (FG)
E	Brake terminal
F	Brake terminal

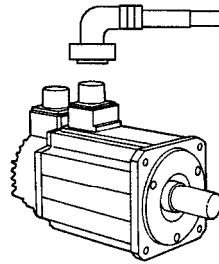
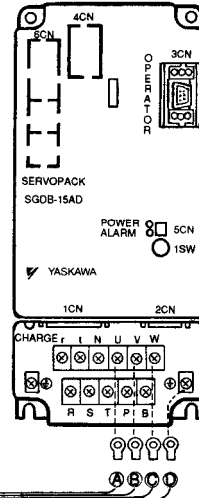
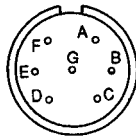

For plug and cable clamp types, refer to Section 5.6.3 Connector.

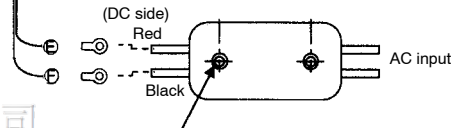

Brake power supply (manufactured by Yaskawa Controls Co., Ltd.)

- 100 VAC input: 90 VDC (LPDE-1H01)
- 200 VAC input: 90 VDC (LPSE-2H01)

3

上正科技有限公司

購買、維修 此手冊零組件

電話： 037-466333

Email: service@repairtw.com

Line id: @zzzz

www.repairtw.com

■ Connectors for Digital Operator

- JUSP-OP02A-1 (Hand-held Type)

- JUSP-OP03A (Mount Type)

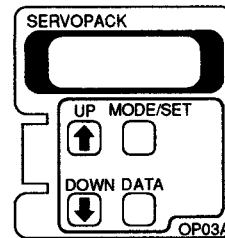
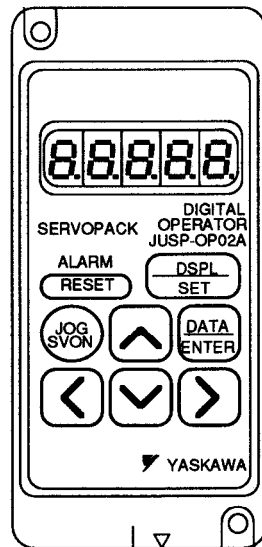

Fits directly into "OPERATOR" on the SERVOPACK.

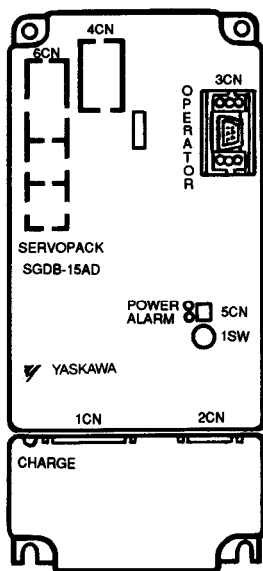

17JE-23090-02
(manufactured by Daiichi
Denshi Kogyo K.K.)

Flat cable
(accessory)

Pin No.	Signal Name	Signal Circuit Name	Signal Direction
1	TXD	Transmit data (non-inversion side)	P ← S
2	/TXD	Transmit data (inversion side)	P ← S
3	RXD	Receive data (non-inversion side)	P → S
4	/RXD	Receive data (inversion side)	P → S
5	OPH		#
6	/RXD	Shorting pins 6 and 7 produces a terminal resistance of 220 Ω between RXD and *RXD.	
7	RT		
8	5VPP		#
9	GND	Signal ground 0 V	

USING THE DIGITAL OPERATOR

This chapter describes the basic operation of the digital operator and the convenient features it offers.

All constant settings and motor operations are possible by simple, convenient, operation.

Operate the digital operator as you read through this chapter.

4.1 Basic Operations	178
4.1.1 Connecting the Digital Operator	178
4.1.2 Digital Operator Functions	179
4.1.3 Resetting Servo Alarms	180
4.1.4 Basic Functions and Mode Selection	181
4.1.5 Operation in Status Display Mode	182
4.1.6 Operation in Parameter Setting Mode	186
4.1.7 Operation in Monitor Mode	191
4.2 Using the Functions	194
4.2.1 Operation in Alarm Trace-back Mode	194
4.2.2 Operation Using the Digital Operator	197
4.2.3 Autotuning	201
4.2.4 Reference Offset Automatic Adjustment	207
4.2.5 Reference Offset Manual Adjustment Mode	210
4.2.6 Clearing Alarm Trace-back Data	213
4.2.7 Checking Motor Specifications	215
4.2.8 Checking Software Version	216
4.2.9 Current Detection Offset Manual Adjustment Mode	217

4.1 Basic Operations

This section describes the basic operations using the Digital Operator.

4.1.1 Connecting the Digital Operator

The Digital Operator is available as two types: JUSP-OP02A-1 (Hand-held Type) and JUSP-OP03A (Mount Type). Each type is connected to the SERVOPACK as shown below.

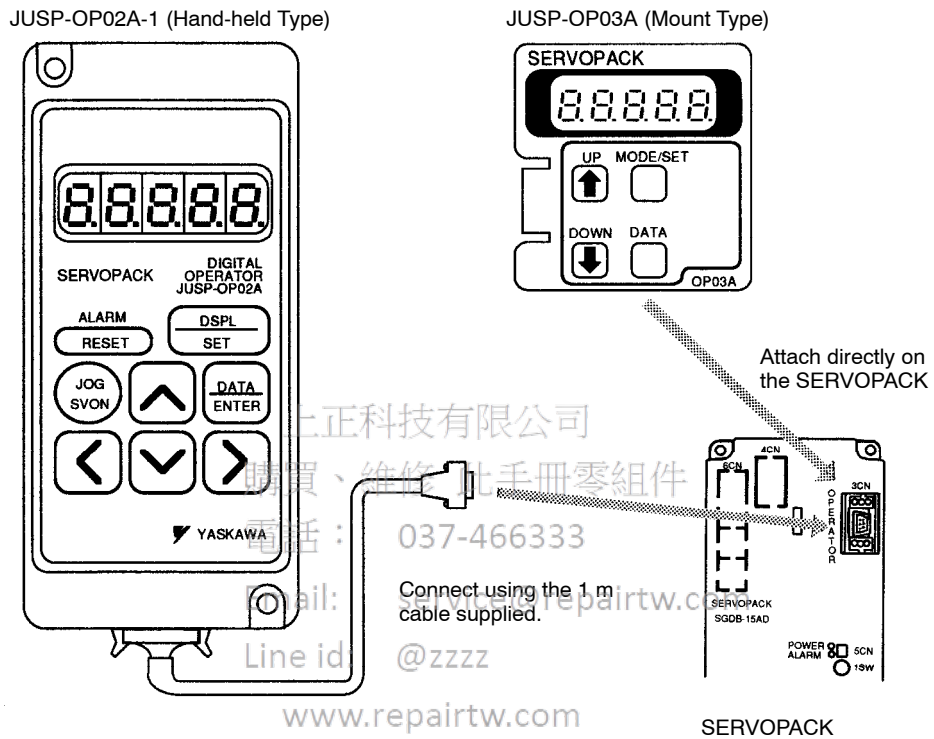

- The Digital Operator connector can be connected or disconnected while the SERVOPACK power is ON.

4.1.2 Digital Operator Functions

The Digital Operator allows the user to set parameters, send commands, and display operating status.

This section describes the key names and functions of the Digital Operator in the initial display status.

Hand-held Digital Operator

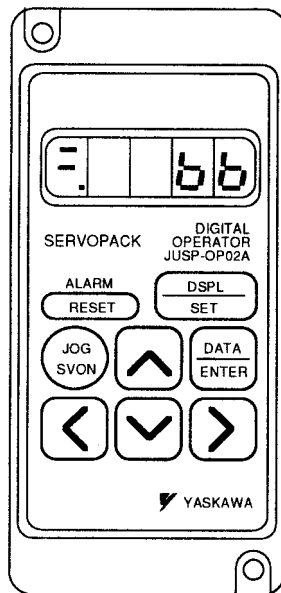

Key	Name	Function
	RESET Key	Press to reset the servo alarm.
	DSPL/SET Key	Press to select the status display mode, setting mode, monitor mode, or error trace-back mode. Used to select data in setting mode.
	DATA/ENTER Key	Press to display the parameter settings and set values.
	Value Change/Jog Keys	Increment/Forward Jog Key Press to increment the set value. Used as a forward start key during jogging.
		Decrement/Reverse Jog Key Press to decrement the set value. Used as a reverse start key during jogging.
	Digit Selection Keys	Digit Down Key Press to select the digit to be changed. The selected digit flashes. The cursor moves right one digit when the Digit Down Key is pressed.
		Digit Up Key The cursor moves left one digit when the Digit Up Key is pressed.
	SVON Key	Press to jog using the Digital Operator.

Mounted Digital Operator

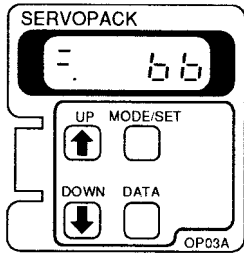

Key	Name	Function
	UP Key	Press to display the parameter settings and set values. Pressing the UP Key increments the set value.
	DOWN Key	Pressing the DOWN Key decrements the set value. Servo alarms can be reset by pressing the UP Key and DOWN Key simultaneously.
	MODE/SET Key	Press to select the status display mode, setting mode, monitor mode, or error trace-back mode.
	DATA Key	Press to display the parameter settings and set values. Can be used as a data setting key in the setting mode.

4.1.3 Resetting Servo Alarms

Servo alarms can be reset using the Digital Operator. (Servo alarms can also be reset by the 1CN-44, /ALMRST input signal. Refer to Section 3.7.1 Using Servo Alarm Output and Alarm Code Output for details.)

The alarm state can be cleared by turning the main power supply OFF, then turning the control power supply OFF.

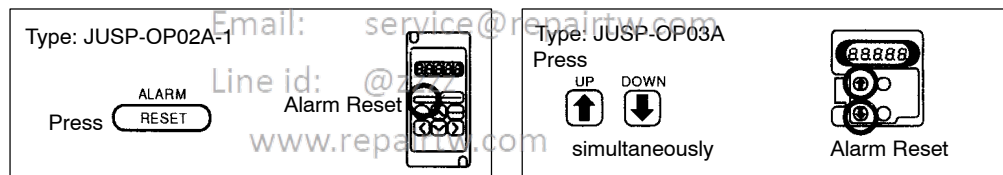

NOTE After an alarm occurs, remove the cause of the alarm before resetting it. Refer to Section 6.2 Troubleshooting to determine and remedy the cause of an alarm.

4.1.4 Basic Functions and Mode Selection

Digital Operator operation allows status display, parameter setting, operating reference, and auto-tuning operations.

Basic Mode Selection

The four basic modes are listed below. Each time the mode key is pressed, the next mode in the sequence is selected.

JUSP-OP02A-1



Press the



key to switch the mode.

JUSP-OP03A

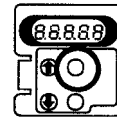

Press the



key to switch the mode.

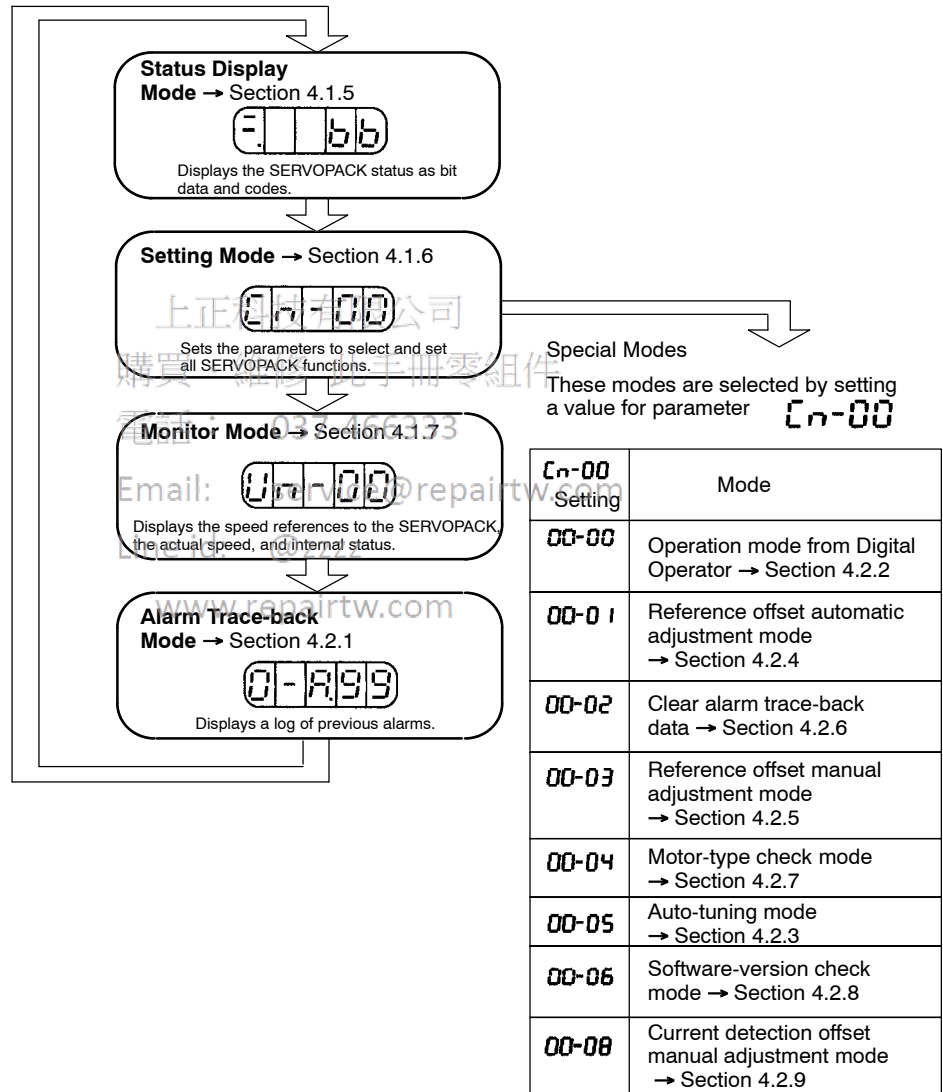

4.1.5 Operation in Status Display Mode

The status display mode displays the SERVOPACK status as bit data and codes.

■ Selecting Status Display Mode

The status display mode is displayed when the power is turned ON. If the status display mode is not displayed, use the procedure shown in 4.1.4 Basic Functions and Mode Selection to set the status display mode.

Keys to the status display are shown below.

For Speed Control

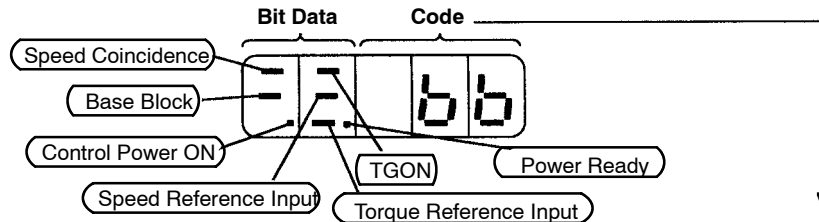

Code	Status
bb	Base block Servo OFF (motor power OFF)
run	Run Servo ON (motor power ON)
Pot	Forward Rotation Prohibited (P-OT) 1CN-42 (P-OT) OFF. See Cn-01 Bit 2 (page 57).
not	Reverse Rotation Prohibited (N-OT) 1CN-43 (N-OT) OFF. See Cn-01 Bit 3 (page 57).
R00	Alarm Status Displays the alarm number. See the table of alarms on page 196.
R02	
}	

Bit Data	Description
Control Power ON	Lit when SERVOPACK control power ON. Not lit when SERVOPACK control power OFF.
Base Block	Lit for base block. Not lit at servo ON.
Speed Coincidence	Lit if motor speed reaches speed reference. Otherwise, not lit.
TGON	Lit if motor speed exceeds preset value. Not lit if motor speed is below preset value. Preset value: Set in Cn-0B (20 min ⁻¹ is factory setting)
Speed Reference Input	Lit if input speed reference exceeds preset value. Not lit if input speed reference is below preset value. Specified value: Set in Cn-0B (20 min ⁻¹ is factory setting)
Torque Reference Input	Lit if input torque reference exceeds preset value. Not lit if input torque reference is below preset value. Preset value: Set in Cn-0B (10% rated torque is standard setting) (Used for torque feed-forward or current restriction)
Power Ready	Lit when main power supply circuit is normal. Not lit when power is OFF or main power supply circuit is faulty.

For Position Control

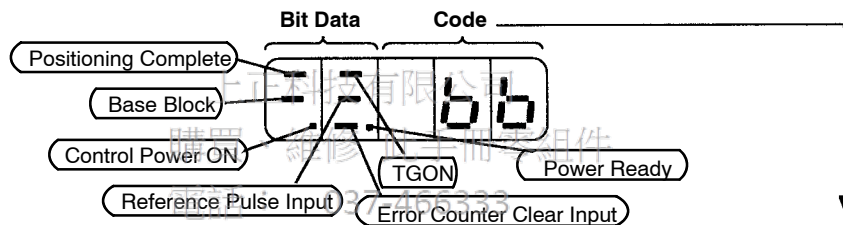

Code	Status
bb	Base block Servo OFF
run	Run Servo ON
Pot	Forward Rotation Prohibited 1CN-42 (P-OT) OFF. See Cn-01 Bit 2 (page 57).
not	Reverse Rotation Prohibited 1CN-43 (N-OT) OFF. See Cn-01 Bit 3 (page 57).
A00	Alarm Status Displays the alarm number. See the table of alarms on page 196.
A02	
}	

Bit Data	Description
Control Power ON	Lit when SERVOPACK control power ON. Not lit when SERVOPACK control power OFF.
Base Block	Lit for base block. Not lit at servo ON.
Positioning Complete	Lit if error between position reference and actual motor position is below preset value. Not lit if error between position reference and actual motor position exceeds preset value. Preset value: Set in Cn-1B (1 pulse is standard setting)
TGON	Lit if motor speed exceeds preset value. Not lit if motor speed is below preset value. Preset value: Set in Cn-0B (20 min ⁻¹ is standard setting)
Reference Pulse Input	Lit if reference pulse is input Not lit if no reference pulse is input.
Error Counter Clear Input	Lit when error counter clear signal is input. Not lit when error counter clear signal is not input.
Power Ready	Lit when main power supply circuit is normal. Not lit when power is OFF or main power supply circuit is faulty.

上正科技有限公司

購買、維修 此手冊零組件

電話： 037-466333

Email: service@repairtw.com

Line id: @zzzz

www.repairtw.com

For Torque Control

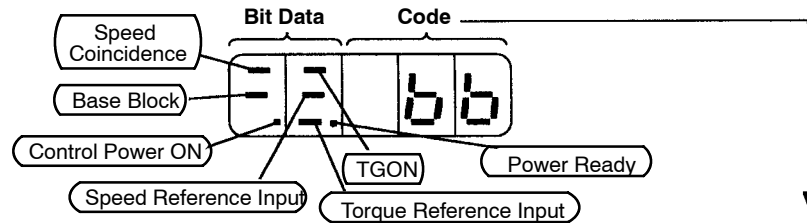

Code	Status
	Base block Servo OFF (motor power OFF)
	Run Servo ON (motor power ON)
	Forward Rotation Prohibited (P-OT) 1CN-42 (P-OT) OFF. See Cn-01 Bit 2 (page 57).
	Reverse Rotation Prohibited (N-OT) 1CN-43 (N-OT) OFF. See Cn-01 Bit 3 (page 57).
	Alarm Status Displays the alarm number. See the table of alarms on page 196.

上正科技有限公司
購買、維修 此手冊零組件

電話： 037-466333

Email: service@repairtw.com

Bit Data	Description
Control Power ON	Lit when SERVOPACK control power ON. Not lit when SERVOPACK control power OFF.
Base Block	Lit for base block. Not lit at servo ON.
Speed Coincidence	Lit if motor speed reaches speed reference. Otherwise, not lit.
TGON	Lit if motor speed exceeds preset value. Not lit if motor speed is below preset value. Preset value: Set in Cn-0B (20 min ⁻¹ is factory setting)
Speed Reference Input	Lit if input speed reference exceeds preset value. Not lit if input speed reference is below preset value. Preset value: Set in Cn-0B (20 min ⁻¹ is factory setting) (Used as speed limit)
Torque Reference Input	Lit if input torque reference exceeds preset value. Not lit if input torque reference is below preset value. Preset value: Set in Cn-0B (10% rated torque is standard setting)
Power Ready	Lit when main power supply circuit is normal. Not lit when power is OFF or main power supply circuit is faulty.

4.1.6 Operation in Parameter Setting Mode

■ Parameter Types

Two types of parameter are used:

- Constant Settings (Cn-03 to Cn-2D)
- Memory Switches (Cn-01, Cn-02)

The setting method is different for each type.

The SERVOPACK offers a large number of functions, which are selected and adjusted by the parameter settings.

The constant settings (Cn-03 to Cn-2D) allow setting of a constant within a fixed range.

The memory switches (Cn-01, Cn-02) allow the required functions to be selected.

Refer to *Appendix C List of Parameters*.

上正科技有限公司

購買、維修 此手冊零組件

電話： 037-466333

Email: service@repairtw.com

Line id: @zzzz

www.repairtw.com

■ Using the Setting Mode for Constant Settings (Cn-03 to Cn-2D)

The constant settings (Cn-03 to Cn-23) allow setting of a constant. Check the permitted range of the constant in *Appendix C List of Parameters*, before changing the data. The example below shows how to change user setting Cn-15 from 100 to 85.

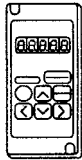

JUSP-OP02A-1

For JUSP-OP02A-1

1. Press to select the parameter setting mode.

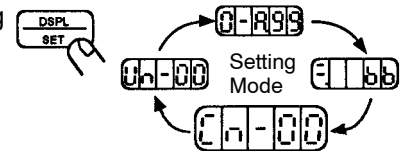

2. Select the parameter number to set.
Press the and keys to select the digit.

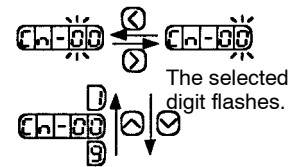

- Press the and keys to change the value.

3. Press to display the current data for the parameter selected at step 2.



4. Set the required data.
Press the and keys to select the digit.

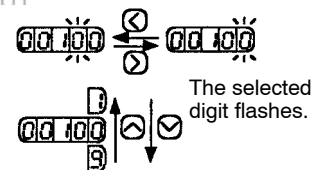

- Press the and keys to change the value.

5. Press to store the data.

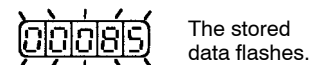

6. Press once more to display the parameter number again.



7. Repeat steps 2 to 6 as often as required.

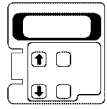



JUSP-OP03A

For JUSP-OP03A

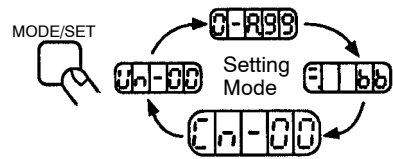
1. Press  to select the parameter setting mode.



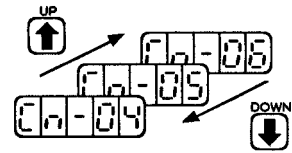

2. Press the  and  keys to select the parameter number to set.

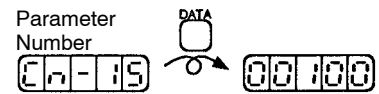

3. Press  to display the current data for the parameter selected at step 2.



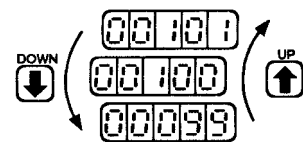

4. Press the  and  keys to change the data to the required value.

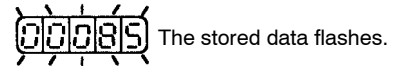

Value changes rapidly when key held down

5. Press  to store the data.



6. Press  once more to display the parameter number again.

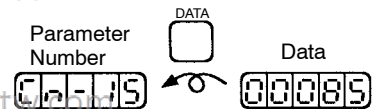

7. Repeat steps 2 to 6 as often as required.

Refer to Appendix C List of Parameters.

■ Using the Setting Mode for Memory Switches (Cn-01, Cn-02)

Turn the bits of the memory switches ON and OFF to select the functions required. The example below shows how to turn ON Bit 4 of memory switch Cn-01.

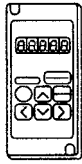

JUSP-OP02A-1

For JUSP-OP02A-1

1. Press to select the parameter setting mode.

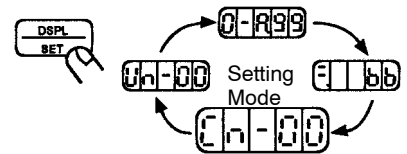

2. Select the parameter number to set. Press the and keys to select the digit.

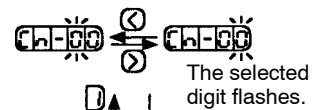

- Press the and keys to change the value.

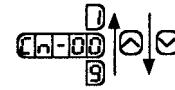

3. Press to display the current data for the memory switch selected at step 2.

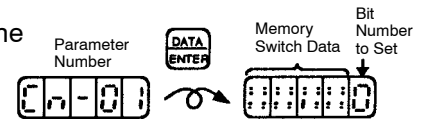

4. Press the and keys to select the bit number to set.

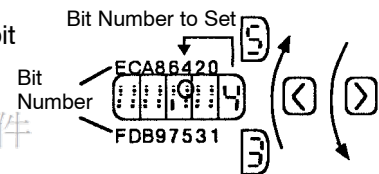

5. Press the and keys to set the memory switch data ON or OFF for the bit number.

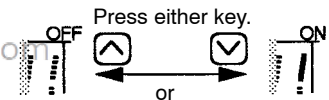

6. Repeat steps 4 and 5 as often as required.

7. Press to store the data.



Turning Bits ON and OFF

Memory switches use bits, not numbers, to select functions.

Sixteen bits are available (1 to 9 and A to F). Select the required functions by turning the appropriate bit ON (function ON) or OFF (function OFF).

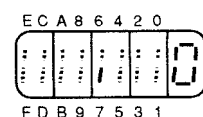

: = OFF
I = ON

8. Press  once more to display the parameter number again.



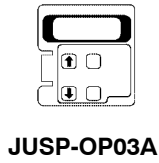

Refer to Appendix C List of Parameters.



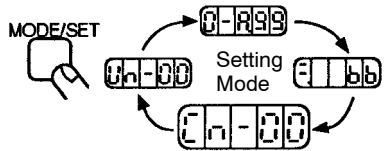

For JUSP-OP03A

1. Press  to select the parameter setting mode.

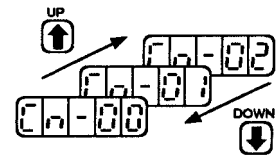

2. Press the  and  keys to select the parameter number to set.



3. Press  to display the current data for the memory switch selected at step 2.

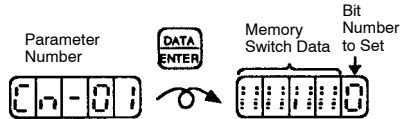

4. Press the  and  keys to select the bit number to set.

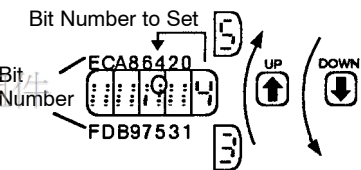

5. Press  to set the memory switch data ON or OFF for the bit number.



6. Repeat steps 4 and 5 as often as required.

7. Press  to store the data.



8. Press  once more to display the parameter number again.



Refer to Appendix C List of Parameter Settings

4.1.7 Operation in Monitor Mode

The monitor mode allows the reference values input into the SERVOPACK, I/O signal status, and SERVOPACK internal status to be monitored. The monitor mode can be set during motor operation.

■ Using the Monitor Mode

The example below shows how to display 1500, the contents of monitor number Un-00.

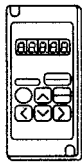

JUSP-OP02A-1

For JUSP-OP02A-1

1. Press to select the monitor mode

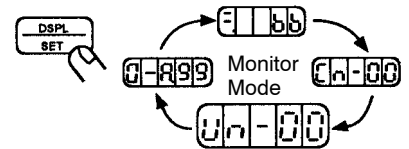

2. Press the and keys to select the monitor number to display.

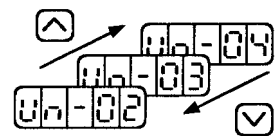

3. Press to display the data for the monitor number selected at step 2.



4. Press once more to display the monitor number again.

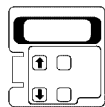

JUSP-OP03A

For JUSP-OP03A

1. Press to select the monitor mode.

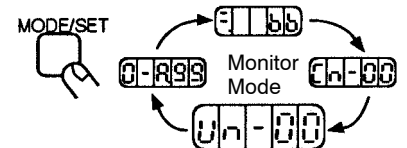

2. Press the and keys to select the monitor number to display.

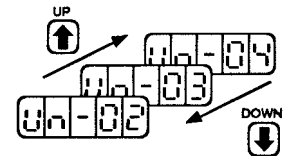

3. Press to display the data for the monitor number selected at step 2.



4. Press once more to display the monitor number again.

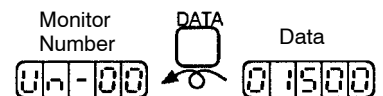

上正科技有限公司
 購買、維修 此子零件組件
 電話： 037-466333
 Email: service@repairtw.com
 www.repairtw.com

■ Monitor Mode Displays

Monitor Number	Monitor Display
Un-00	Actual motor speed Units: min ⁻¹ .
Un-01	Input speed reference Units: min ⁻¹ .
Un-02	Internal torque reference Units: % (with respect to rated torque)
Un-03	Number of pulses from motor U-phase edge Units: pulses
Un-04	Electrical angle Units: 0.1 deg
Un-05	Internal status bit display
Un-06	Internal status bit display
Un-07	Input reference pulse speed display Units: min ⁻¹ .
Un-08	Positional error Units: x1 reference unit (Cn-02 Bit E = 0) x100 reference unit (Cn-02 Bit E = 1)
Un-09	Reference pulse counter reading Units: reference units A value between 0 to 65535 inclusive is displayed.

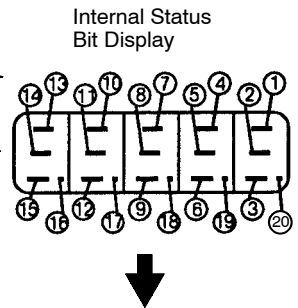

4

Monitor No	Bit No	Description	Related I/O Signal, Parameter	
Un-05	1	Servo alarm	1CN-31 (ALM)	
	2	Dynamic brake ON		
	3	Reverse rotation mode	Cn-02 Bit 0, 2CN-7 (DIR)	
	4	During motor rotation		
	5	Speed coincidence or positioning complete		
	6	Mode switch ON		
	7	During forward current limit	Or contact input speed control	1CN-45 (/P-CL)
	8	During reverse current limit		1CN-46 (/N-CL)
	9	Motor power ON		
	10	A-phase	2CN-16(PA), 2CN-17(/PA)	
	11	B-phase	2CN-18(PB), 2CN-19(/PB)	
	12	C-phase	2CN-14(PC), 2CN-15(/PC)	
	13	U-phase		
	14	V-phase		
	15	W-phase		
	16	Servo ON	1CN-40 (/S-ON)	
	17	P operation or rotation direction input	1CN-41 (/P-CON)	
	18	Forward overtravel	1CN-42 (P-OT), Cn-01 Bit 2	
	19	Reverse overtravel	1CN-43 (N-OT), Cn-01 Bit 3	
	20	SEN signal input	1CN-4 (SEN), Cn-01 Bit 1	

Monitor No	Bit No	Description	Related I/O Signal, Parameter
Un-06	1	Input reference pulse	1CN-7 (PLUS), 1CN-8 (/PULS)
	2	Input pulse sign	1CN-11 (SIGN), 1CN-12 (/SIGN)
	3	Error counter clear input	1CN-15 (CLR), 1CN-14 (/CLR)
	4	Current limit	
	5	Brake interlock output	
	6	Overload warning	
	7	Main power supply ON	
	8	Servo ready	
	9 to 20	Not used	

上正科技有限公司

購買、維修 此手冊零組件

電話： 037-466333

Email: service@repairtw.com

Line id: @zzzz

www.repairtw.com

4.2 Using the Functions

This section describes how to use the basic operations described in section 1 to operate and adjust the motor.

4.2.1 Operation in Alarm Trace-back Mode

The alarm trace-back mode displays up to ten alarms which occurred previously. By allowing confirmation of what alarm occurred when, it is a useful aid to speed up troubleshooting.

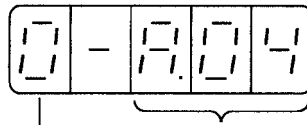

Alarm Sequence Number
The higher the number,
the older the alarm data

Alarm Code

See the table of
alarms on page 196.

NOTE The alarm trace-back data is not cleared on alarm reset or when the SERVOPACK power is turned OFF. This does not adversely affect operation. The data is cleared using the special mode: Clear alarm trace-back data. Refer to *Section 4.2.6 Clearing Alarm Trace-back Data* for details.

電話： 037-466333

Email: service@repairtw.com

Line id: @zzzz

www.repairtw.com

■ Using the Alarm Trace-back Mode

Follow the procedure below to determine which alarms occurred previously.



JUSP-OP02A-1

For JUSP-OP02A-1

1. Press to select the alarm trace-back mode.

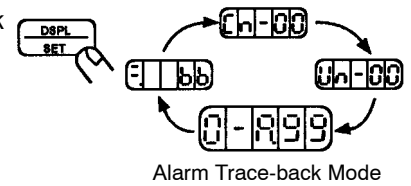

2. Press the and keys to scroll the alarm sequence numbers up and down and display information on previous alarms. The higher the left-hand digit (alarm sequence number), the older the alarm data.

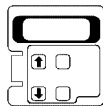
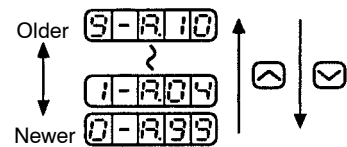

JUSP-OP03A

For JUSP-OP03A

1. Press to select the alarm trace-back mode.

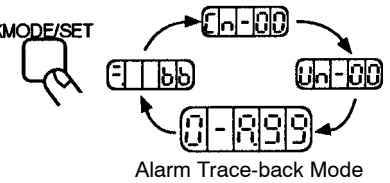

2. Press the and keys to scroll the alarm sequence numbers up and down and display information on previous alarms. The higher the left-hand digit (alarm sequence number), the older the alarm data.

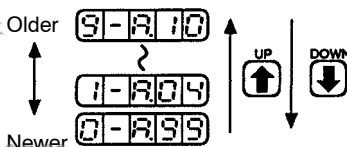

上正科技有限公司

買、維修、此手冊電組件
電話: 037-469333
Email: service@repairtw.com

Line id: @zzzz

www.repairtw.com

■ Alarm Display Contents

The table below lists the alarms displayed in the alarm trace-back mode.

Displayed Alarm Code	Description
R00	Absolute data error
R02	Parameter breakdown
R04	Parameter setting error
R10	Overcurrent
R30	Regenerative error
R31	Position error pulse overflow
R40	Main circuit voltage error detection
R51	Overspeed
R71	Overload(Instantaneous)
R72	Overload(Continuous)
R80	Absolute encoder error
R81	Absolute encoder back-up error
R82	Absolute encoder checksum error
R83	Absolute encoder battery error
R84	Absolute encoder data error
R85	Absolute encoder overspeed
RA1	Heat sink overheated
Rb1	Reference input read error
RC1	Servo overrun detected *
RC2	Encoder output phase error
RC3	Encoder A-, B-phase disconnection
RC4	Encoder C-phase disconnection
RF1	Power line open phase
RF3	Power loss error.
R99	Not an alarm. Reset by alarm reset or SERVOPACK power ON.

* This function prevents overrun.

The following are operator-related alarms which are not recorded by alarm trace-back.

CPFD0	Digital Operator transmission error 1
CPFD1	Digital Operator transmission error 2

- Refer to the troubleshooting procedures when an alarm occurs, described in *Section 6.2 Troubleshooting*.

4.2.2 Operation Using the Digital Operator



Simple Motor Check

Operation from the Digital Operator allows the SERVOPACK to run the motor. This allows rapid checking of basic operations during machine set-up and testing, without the trouble of connecting a host controller.

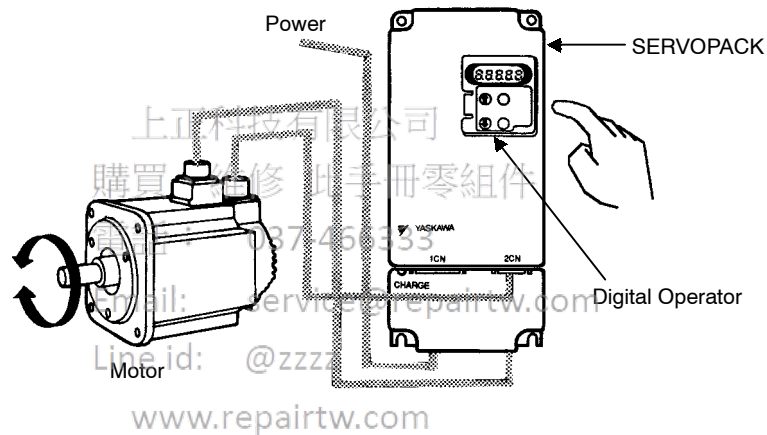

■ Operation Using the Digital Operator

Use the following procedure to operate the motor from the Digital Operator

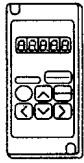

JUSP-OP02A-1

For JUSP-OP02A-1

1. Press to select the parameter setting mode.

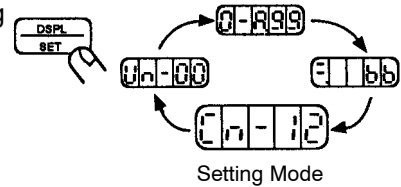

2. Select the parameter number Cn-00.
(Parameter Cn-00 is selected when the power is turned ON.)

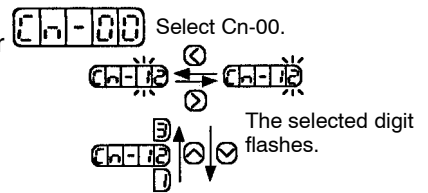

Press the and keys to select the digit.

Press the and keys to change the value.

3. Press to display the current data for the parameter Cn-00.



4. Press the and keys to change the data to 00.

Set to 00-00.

(This parameter is set to 00 when the power is turned ON.)

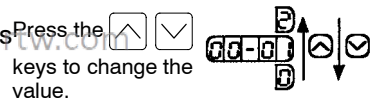

5. Press to set the Digital Operator in operation mode. Operation is now possible under Digital Operator control.

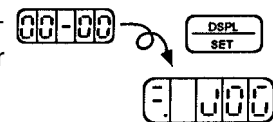

Display for operation mode from Digital Operator

6. Press to set the servo ON status (motor power turned ON).

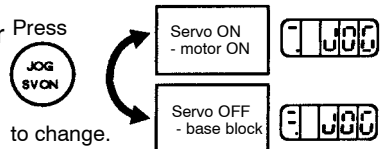

上正科技有限公司
購買、維修 此手冊零組件
電話：057-466333
Email: service@repairtw.com
Line id: @zzzz
www.repairtw.com

7. Press the and keys to operate the motor.

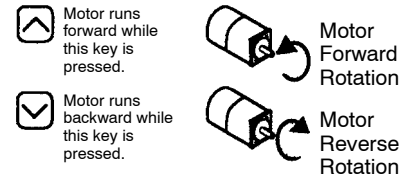

8. Press to revert to . This sets the servo OFF status (motor power turned OFF).

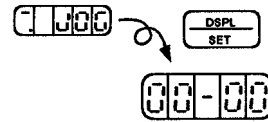

(Alternatively, press to set the servo OFF status.)

9. Press to return to the setting mode display. This disables operation under Digital Operator control.

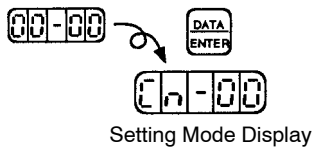

For JUSP-OP03A-1

1. Press to select the parameter setting mode.

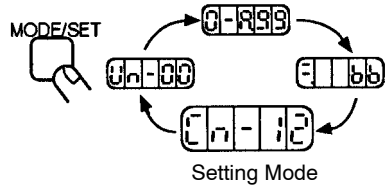

2. Press the and keys to select the parameter number Cn-00. (Parameter Cn-00 is selected when the power is turned ON.)

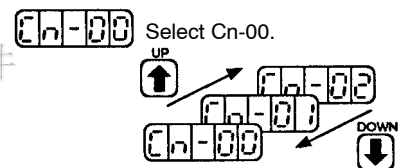

3. Press to display the current data for the parameter Cn-00.

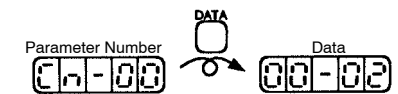

4. Press the and keys to change the data to 00. (This parameter is set to 00 when the power is turned ON.)

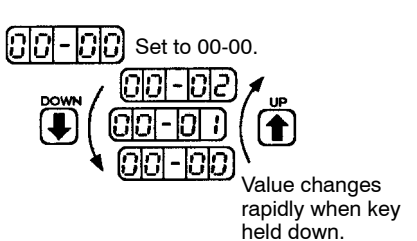

5. Press to set the Digital Operator in operation mode. Operation is now possible under Digital Operator control.

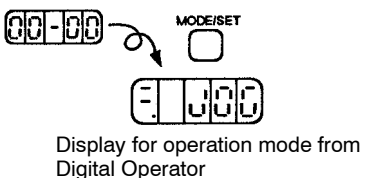

6. Press to set the servo ON status (motor power turned ON).

Press DATA to change.

Servo ON - motor ON

Servo OFF - base block

7. Press the and keys to operate the motor.

Motor runs forward while this key is pressed. Motor Forward Rotation

Motor runs backward while this key is pressed. Motor Reverse Rotation

8. Press to revert to . This sets the servo OFF status (motor power turned OFF).

9. Press to return to the setting mode display. This disables operation under Digital Operator control.

Setting Mode Display

■ Changing Motor Speed

The motor speed for operation under Digital Operator control can be changed with a parameter:

Parameter: Cn-10 (JOGSPD), Units: min⁻¹, Standard setting: 500

For details about setting the motor speed, refer to Section 4.1.6 Operation in Parameter Setting Mode and Appendix C List of Parameters.

上正科技有限公司
 購買、維修、此子零件組件
 電話: 037-466333
 Email: service@repairtw.com
 Line id: @zzzz
 www.repairtw.com

4.2.3 Autotuning



No experience required to achieve optimum settings.

The SERVOPACK contains a built-in autotuning function to automatically measure the machine characteristics and set the parameters.

Servo drives normally require tuning to match the machine configuration and rigidity. This tuning requires a great deal of experience and is difficult for a person unfamiliar with the tuning procedure.



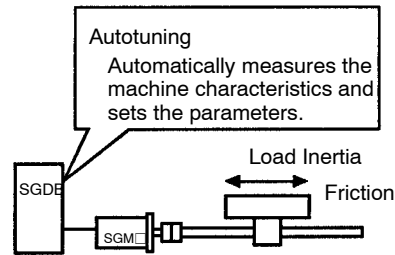

However, autotuning allows even totally inexperienced people to easily complete the tuning.



■ Precautions Relating to Autotuning

Speed Setting During Autotuning

The motor speed during autotuning is set by parameter Cn-10. Set to 500 min^{-1} , which is the factory setting. Autotuning may be unsuccessful if this value is set too low.

The motor runs intermittently while the  or  (or  or ) key is held down. The motor does not rotate continuously.

Machine Rigidity Selection



Select the machine rigidity as described below. If the actual rigidity is unknown, select medium rigidity.





 High Rigidity

 Medium Rigidity





 Low Rigidity

- If the Machine Resonates

At servo ON when the  (or ) key is pressed or when the motor is operated by





pressing the  or  ( or ) key, machine resonance indicates an inappropriate machine rigidity setting.

Follow the procedure below to correct the machine rigidity setting, and run autotuning once more.

1. Press the  (or ) key to cancel autotuning.
2. Press the  (or ) key once more to enter the machine rigidity setting mode. Reduce the setting by one.

• If Autotuning Does Not End

Failure of autotuning to end  , is caused by an inappropriate machine rigidity setting. Follow the procedure below to correct the machine rigidity setting, and run autotuning once more.

1. Press the  (or ) key to cancel autotuning.
2. Press the  (or ) key once more to enter the machine rigidity setting mode. Increase the setting by one.

Autotuning may not end for machines with large play or extremely low rigidity. In these cases, use conventional manual adjustment.

Input Signals

- The P-OT signal, N-OT signal and SEN signal (absolute encoder only) are enabled during autotuning. Input the P-OT signal, N-OT signal and SEN signal (absolute encoder only) during autotuning. To conduct autotuning without inputting these signals, set parameter Cn-01 Bits 1, 2, and 3 to 1.

- Autotuning is not possible during overtravel (P-OT or N-OT signal OFF).

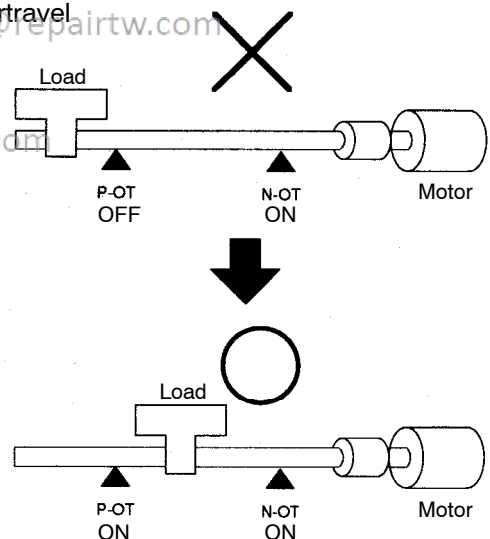

- Conduct autotuning when no overtravel has occurred (both P-OT and N-OT signal ON).

- When performing autotuning, set the P-CON signal to OFF status.
- When using the mode switching function, perform autotuning after performing one of the following operations:
 - Not using mode switching.
 - Setting a higher mode switching level.

Refer to 3.6.6 Using Mode Switch for details on mode switch function.

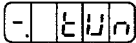
- If using the /S-ON signal to set the servo ON status, display  before turning ON the /S-ON signal.

■ Parameters Automatically Settable with Autotuning

Cn-04	Speed loop gain
Cn-05	Speed loop integration time constant
Cn-1A	Position loop gain

Once autotuning has been completed, the autotuning procedure can be omitted for subsequent machines, providing the machine specifications remain unchanged.

It is sufficient to directly set the parameters for subsequent machines.

The **machine rigidity** can be selected from one of seven levels.

購買、維修 此手冊零組件

電話： 037-466333

Email: service@repairtw.com

Line id: @zzzz

www.repairtw.com

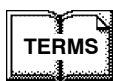

Machine Rigidity

The machine rigidity is one of the machine characteristics related to servo control. Set the servo to high response for a machine, such as a machine tool, with high rigidity, and to low response for a machine, such as a robot, with low rigidity.

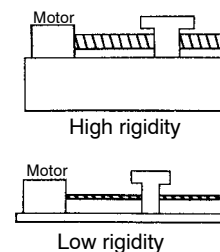

■ Using Autotuning

Follow the procedure below to run autotuning.

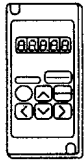

JUSP-OP02A-1

For JUSP-OP02A-1

1. Press to select the parameter setting mode.

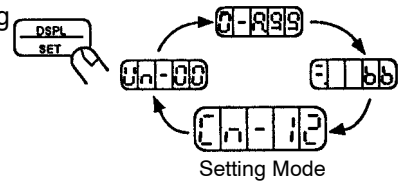

2. Select the parameter number Cn-00.
(Parameter Cn-00 is selected when the power is turned ON.)

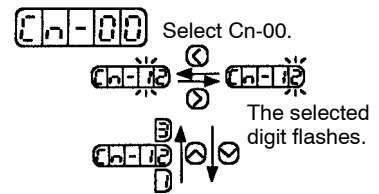

Press the and keys to select the digit.

Press the and keys to change the value.

3. Press to display the current data for the parameter Cn-00.

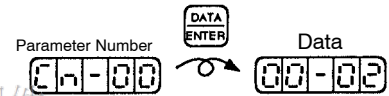

4. Press the and keys to change the data to 05.

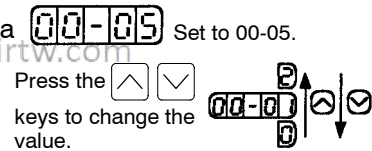

5. Press to display the machine rigidity.

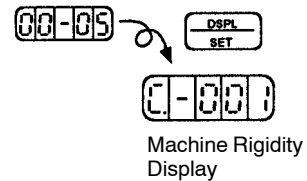

6. Press the and keys to select the machine rigidity. If the actual rigidity is unknown, select medium rigidity (C-003 to C-005).

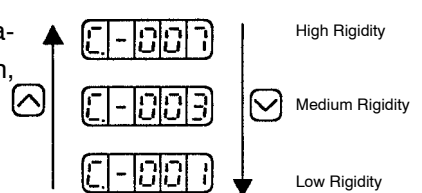

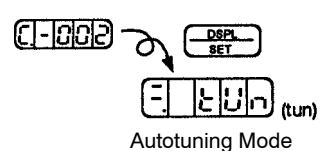

7. Press to select autotuning mode.

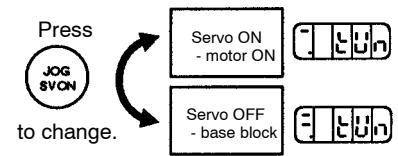

8. Press  to set the servo ON status.



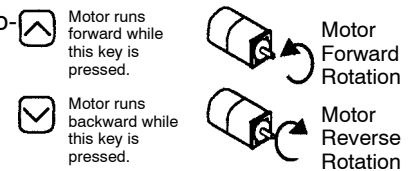

9. Press the  and  keys to operate the motor.

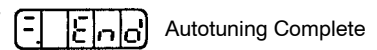

10. When autotuning is complete, the END message is displayed, as shown to the right. Servo OFF status is automatically selected. If Servo ON/Servo OFF is selected by a signal from an external contact, turn this signal OFF.

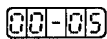

11. Release the  and  keys to revert to the  display.



12. Press  to return to the setting mode display. This ends the autotuning operation.

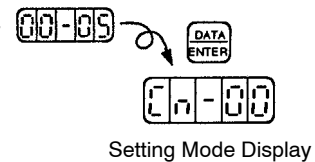

上正科技有限公司

For JUSP-OP03A 購買、維修 此手冊零組件



JUSP-OP03A



MODE/SET 電話： 037-466333

1. Press  to select the parameter setting mode. Email: service@repairtw.com

Line id: @zzzz

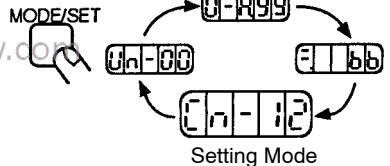
www.repairtw.com





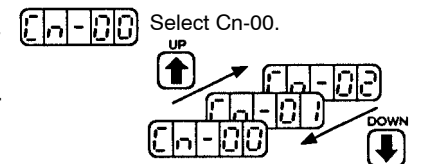

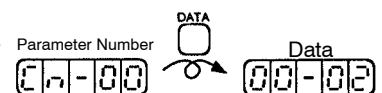

2. Press the  and  keys to select the parameter number Cn-00. (Parameter Cn-00 is selected when the power is turned ON.)



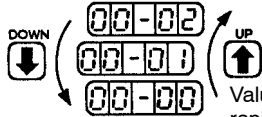



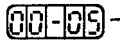

3. Press  to display the current data for the parameter Cn-00.



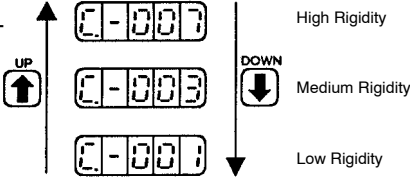



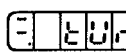

4. Press the  and  keys to change the data  Set to 00-05 to 05.
- 
- Value changes rapidly when key held down.

5. Press  to display the machine rigidity.   
- Machine Rigidity Display





6. Press the  and  keys to select the machine rigidity (C-001 to C-007).
- 



7. Press  to select autotuning mode.   
- Autotuning Mode

8. Press  to set the servo ON status.
- Press  to change.
- | | |
|------------------------|---|
| Servo ON - motor ON |  |
| Servo OFF - base block |  |
- 上正科技有限公司
 購買、維修 此手冊零組件
 電話： 037-466333
 Email: service@repairtw.com

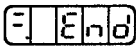
9. Press the  and  keys to operate the motor.
- | | | | |
|---|--|---|------------------------|
|  | Motor runs forward while this key is pressed. |  | Motor Forward Rotation |
|  | Motor runs backward while this key is pressed. |  | Motor Reverse Rotation |

10. When autotuning is complete, the END message is displayed.  Autotuning Complete
- Servo OFF status is automatically selected. If Servo ON/Servo OFF is selected by a signal from an external contact, turn this signal OFF.

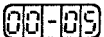
11. Release the  and  keys to revert to the   display.

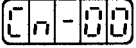
12. Press  to return to the setting mode display.   
This ends autotuning operation.
Setting Mode Display

4.2.4 Reference Offset Automatic Adjustment

■ Why Does Reference Offset Occur?

The motor may rotate slowly when the reference voltage is intended to be 0 V. This occurs when the host controller or external circuit has a small offset (measured in mV) in the reference voltage.



Automatic Adjustment of Reference Voltage

The reference offset automatic adjustment mode automatically measures the offset and adjusts the reference voltage. It adjusts both speed and torque references.

The following diagram illustrates automatic adjustment of an offset in the reference voltage from the host controller or external circuit.

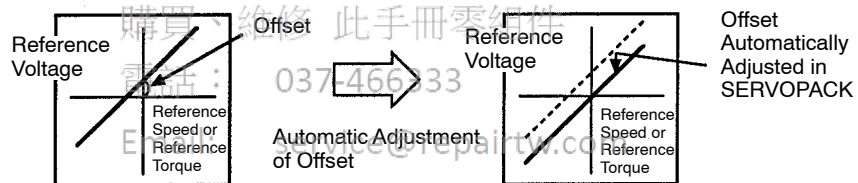

After completion of offset automatic adjustment, the amount of offset is stored in the SERVOPACK.

The amount of offset can be checked in the speed reference offset manual adjustment mode. Refer to *Section 4.2.5 Reference Offset Manual Adjustment Mode* for details.

The reference offset automatic adjustment mode cannot be used where a position loop is formed with the host controller and the error pulses are zeroed when servo lock is stopped.

In this case, use the speed reference offset manual adjustment mode. Refer to *Section 4.2.5 Reference Offset Manual Adjustment Mode* for details.

Zero-clamp speed control is available to force the motor to stop during zero speed reference. Refer to *Section 3.4.3 Using Zero-Clamp* for details.

■ Using the Reference Offset Automatic Adjustment Mode

Follow the procedure below to automatically adjust the reference offset.

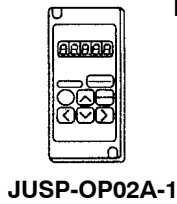

For JUSP-OP02A-1

1. Follow the procedure below to set the motor into operating mode.

(1) Input the (intended) 0 V reference voltage from the host controller or external circuit.

(2) Then, turn ON the servo ON (1CN-40, $\overline{S-ON}$) signal.

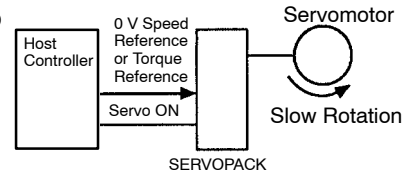

2. Press to select the parameter setting mode.

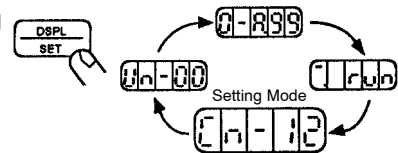

3. Select the parameter number Cn-00. (Parameter Cn-00 is selected when the power is turned ON.)

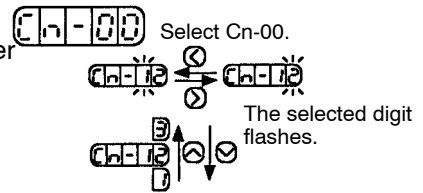

Press the and keys to select the digit.

Press the and keys to change the value.

4. Press to display the current data for the parameter Cn-00.

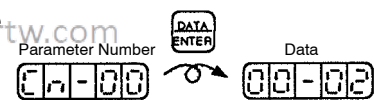

5. Press the and keys to change the data to 01.

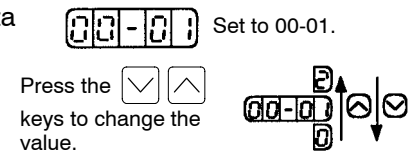

6. Press to automatically adjust the reference offset. The motor rotation stops.

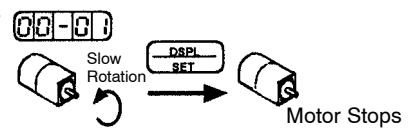

7. Press to return to the setting mode display. This ends reference offset automatic adjustment.

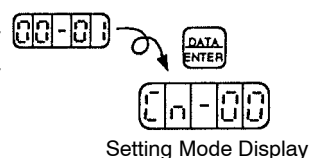

上正科技有限公司
 購買、維修、此等零件
 電話：037-466333
 Email: service@repairtw.com
 Line id: @zzzz
 www.repairtw.com

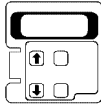

JUSP-OP03A

For JUSP-OP03A

1. Follow the procedure below to set the motor into operating mode.

- (1) Input the (intended) 0V reference voltage from the host controller or external circuit.
- (2) Then, turn ON the servo ON (1CN-40, /S-ON) signal.

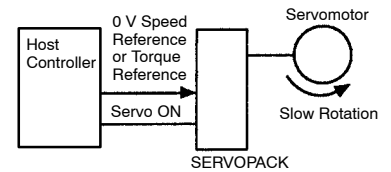

2. Press MODE/SET to select the parameter setting mode.

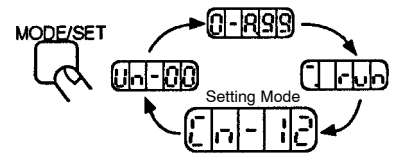

3. Press the and keys to select the parameter number Cn-00. (Parameter Cn-00 is selected when the power is turned ON.)

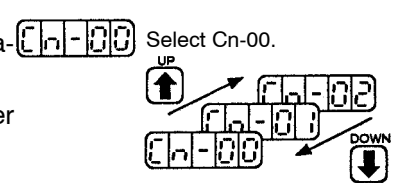

4. Press DATA to display the current data for the parameter Cn-00.



5. Press the and keys to change the data to 01.

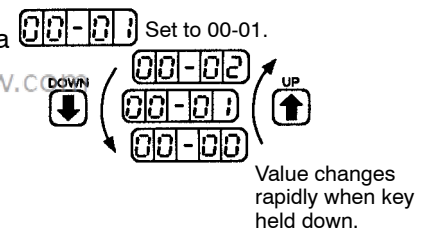

6. Press MODE/SET to automatically adjust the reference offset. The motor rotation stops.

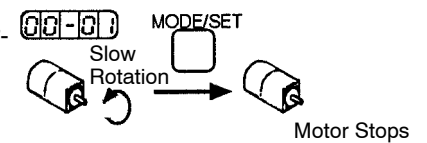

7. Press DATA to return to the setting mode display. This ends reference offset automatic adjustment.

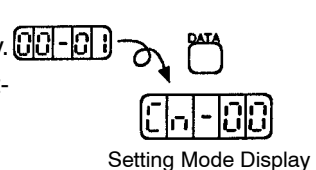

上正科技有限公司
 購買、維修 此手冊零組件
 電話: 037-466333
 Email: service@repairtw.com
 Line id: @zzzz
 www.repairtw.com

4.2.5 Reference Offset Manual Adjustment Mode

Speed reference offset manual adjustment is very convenient in the following situations:

- If a loop is formed with the host controller and the error is zeroed when servo lock is stopped.
- To deliberately set the offset to some value.

This mode can also be used to check the data set in the reference offset automatic adjustment mode.

In principle, this mode operates in the same way as the reference offset automatic adjustment mode, except that the amount of offset is directly input during the adjustment.

Offset Adjustment Range and Setting Units are as follows:

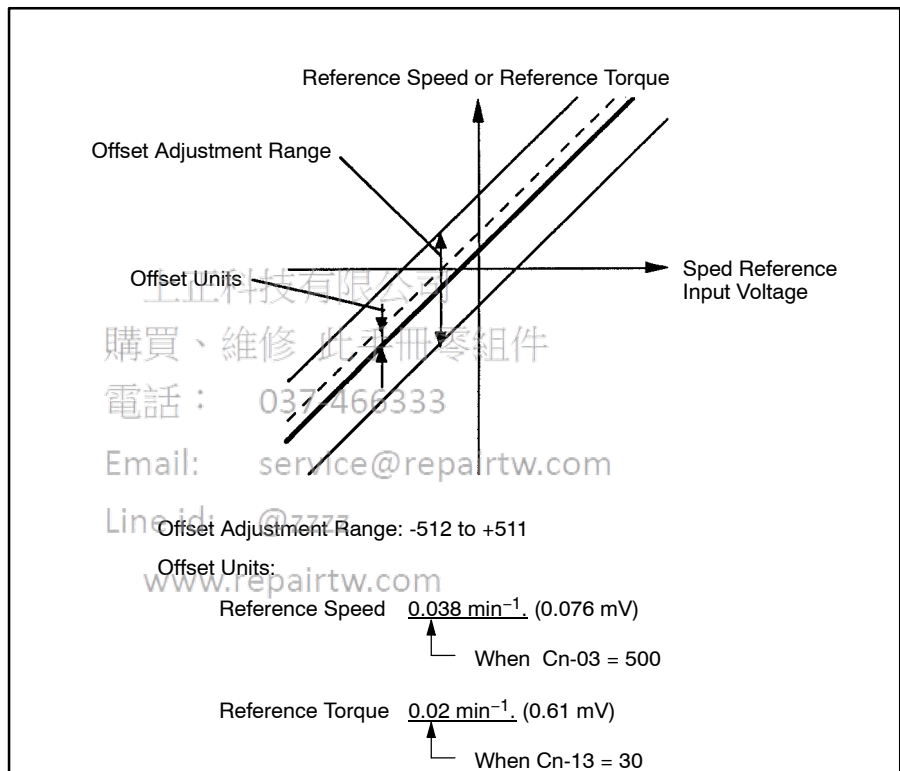

Follow the procedure below to manually adjust the reference voltage.

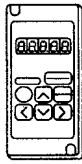

JUSP-OP02A-1

For JUSP-OP02A-1

1. Press to select the parameter setting mode.

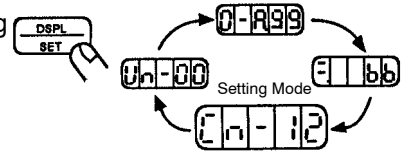

2. Select the parameter number Cn-00.
(Parameter Cn-00 is selected when the power is turned ON.)

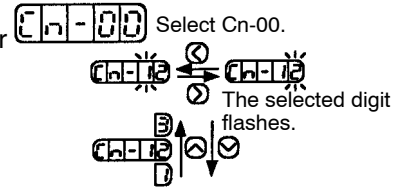

Press the and keys to select the digit.

Press and keys to change the value.

3. Press to display the current data for the parameter Cn-00.

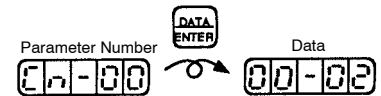

4. Press the and keys to change the data to 03.

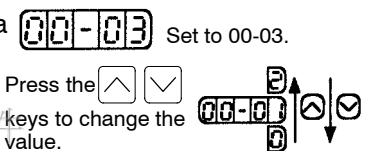

5. Press to select the speed reference offset manual adjustment mode.
The amount of speed reference offset is displayed.

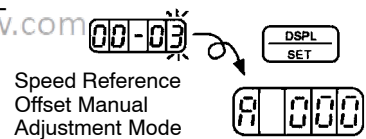

6. Press the and keys to adjust the amount of offset.
(Adjust the speed references.)

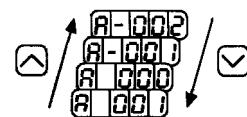

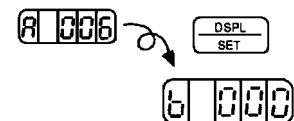

7. Press to select the torque reference offset manual adjustment mode.
The amount of torque reference offset is displayed.

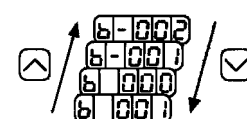

8. Press the and keys to adjust the amount of offset.
(Adjust the torque references.)



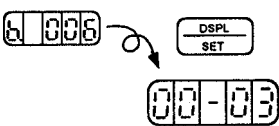

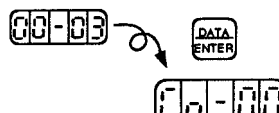







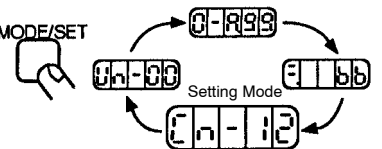

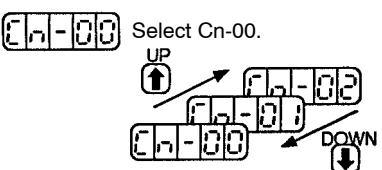

上正科技有限公司
 購買、維修 此手冊零組件
 電話： 037-466333
 Email: service@repairtw.com
 Line id: @z773
 www.repairtw.com

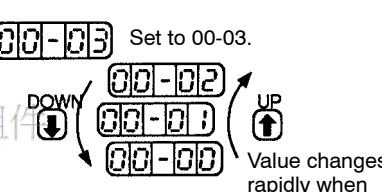

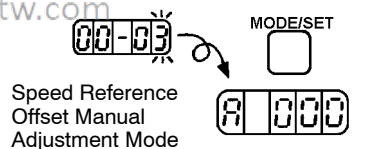
9. Press  to return to the parameter data display. 
10. Press  to return to the setting mode display. This ends the reference offset manual adjustment. 

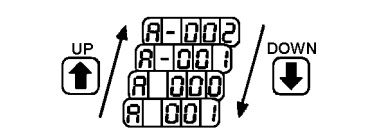
Setting Mode Display

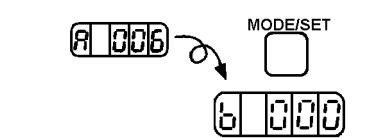

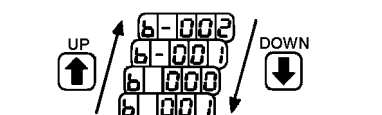
For JUSP-OP03A

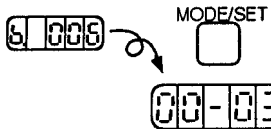
1. Press  to select the parameter setting mode. 
2. Press the  and  keys to select the parameter number Cn-00. (Parameter Cn-00 is selected when the power is turned ON.) 
3. Press  to display the current data for the parameter Cn-00. 
4. Press the  and  keys to change the data to 03. 
Value changes rapidly when key held down.
5. Press  to select the speed reference offset manual adjustment mode. The amount of speed reference offset is displayed. 
6. Press the  and  keys to adjust the amount of offset. (Adjust the speed references.) 
7. Press  to select the torque reference offset manual adjustment mode. The amount of torque reference offset is displayed. 
8. Press the  and  keys to adjust the amount of offset. (Adjust the torque references.) 

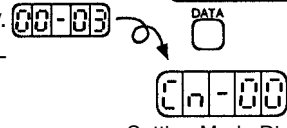
9. Press  to return to the parameter data display. 
 10. Press  to return to the setting mode display.  This ends the reference offset manual adjustment.
- Setting Mode Display

4.2.6 Clearing Alarm Trace-back Data





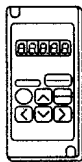





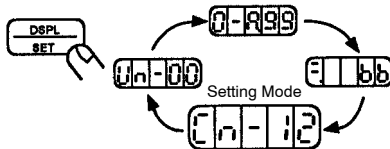
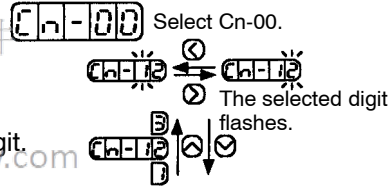

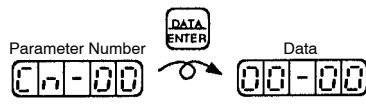

This procedure clears the alarm history, which stores the alarms occurring in the SERVO-PACK. Each alarm in the alarm history is set to A99, which is not an alarm code. Refer to *Section 4.2.1 Operation in Alarm Trace-back Mode* for details.

Follow the procedure below to clear the alarm trace-back data.

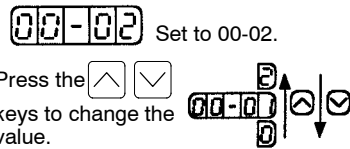

JUSP-OP02A-1

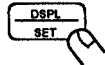
For JUSP-OP02A-1



1. Press  to select the parameter setting mode. 
2. Select the parameter number Cn-00. (Parameter Cn-00 is selected when the power is turned ON.)  Press the  and  keys to select the digit. Press the  and  keys to change the value.
 Select Cn-00. The selected digit flashes.
3. Press  to display the current data for the parameter Cn-00. 
4. Press the  and  keys to change the data to 02.  Set to 00-02. Press the  and  keys to change the value.
5. Press  to clear the alarm trace-back data.  Clear the alarm trace-back data.
6. Press  to return to the parameter number display. 



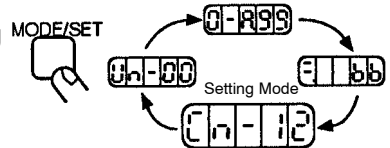

For JUSP-OP03A

1. Press  to select the parameter setting mode.



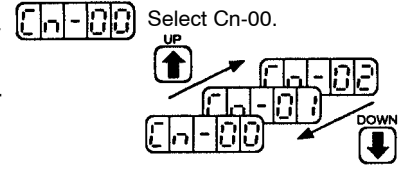

2. Press the  and  keys to select the parameter number Cn-00. (Parameter Cn-00 is selected when the power is turned ON.)

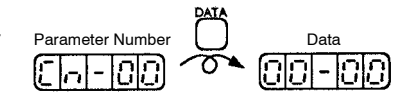

3. Press  to display the current data for the parameter Cn-00.



4. Press the  and  keys to change the data to 02.

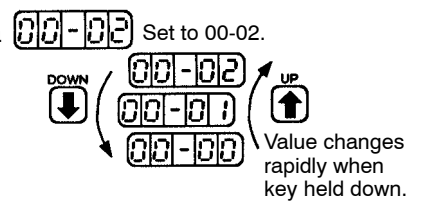

5. Press  to clear the alarm trace-back data.



6. Press  to return to the parameter number display.

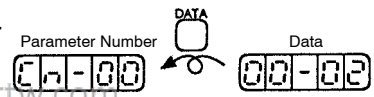

4

上正科技有限公司
 購買、維修 此手冊零組件
 電話：027-163322
 Email: service@repairtw.com
 Line id: @zzzz
 www.repairtw.com

4.2.7 Checking Motor Specifications

This mode used for maintaining the motor.

When Cn-00 is set to 00-04, this mode is used to check the motor specifications.

Use the following procedure to check the motor specifications.

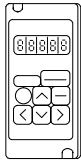

Hand-held Digital Operator

1. Set Cn-00 to 00-04.
2. Press the DSPL/SET Key.

The motor capacity is displayed.

Motor Capacity Display

F0005

Motor model
0: Σ Series

Motor Capacity

05: 0.3 kW	2C: 4.4 kW
0.5 kW	5.0 kW
0A: 0.7 kW	3C: 6.0 kW
1.0 kW	4B: 7.5 kW
0F: 1.5 kW	6E: 11.0 kW
14: 2.0 kW	96: 15.0 kW
1E: 3.0 kW	

3. Press the DSPL/SET Key.

The special specification (Y specification) is displayed.

Special Specification
(Y Specification) Display

9007A

(Hexadecimal notation)

(1) (2) (3) (4)

$$(1) \times 16^3 + (2) \times 16^2 + (3) \times 16 + (4) = \text{special specification (Y specification number)}$$

Checking of the motor specifications has now been completed.

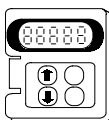

Mounted Digital Operator

1. Set Cn-00 to 00-04.
2. Press the MODE/SET Key.

The motor capacity is displayed.

3. Press the MODE/SET Key.

The special specification (Y specification) is displayed.

Checking of the motor specifications has now been completed.

4.2.8 Checking Software Version

This mode is used for maintaining the motor.

When Cn-00 is set to 00-06, this mode is used to check the software version.

Use the following procedure to check the software version.

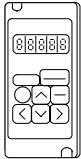

Hand-held Digital Operator

1. Set Cn-00 to 00-06.
2. Press the DSPL/SET Key.

The software version is displayed.

Software Version Display

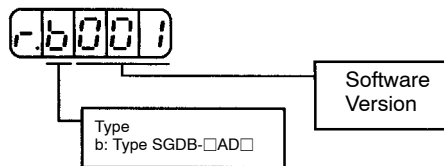

Checking of the software version has now been completed.

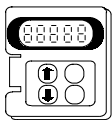

Mounted Digital Operator

1. Set Cn-00 to 00-06.
2. Press the MODE/SET Key.

The software version is displayed.

3. Press the MODE/SET Key.

The software version is displayed.

Checking of the software version has now been completed.

4.2.9 Current Detection Offset Manual Adjustment Mode

Current detection offset manual adjustment is performed at Yaskawa before shipping. Basically, the customer need not perform this adjustment. Perform this adjustment only if highly accurate adjustment is required when the Digital Operator is combined with a specific motor.

Run the motor at a speed of approximately 100 min⁻¹, and adjust the Digital Operator until the torque monitor ripple is minimized. Adjust the U-phase and V-phase offsets alternately several times until these offsets are well balanced.

Follow the procedure below to perform current detection offset manual adjustment.



JUSP-OP02A-1

For JUSP-OP02A-1

1. Press to select the parameter setting mode.

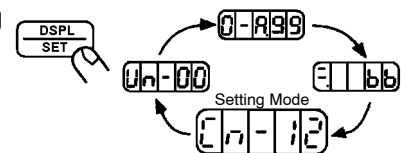

2. Select the parameter number Cn-00.
(Parameter Cn-00 is selected when the power is turned ON.)

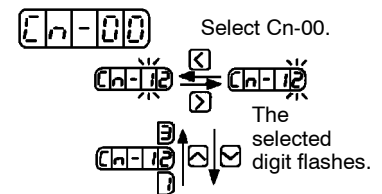

Press the and keys to select the digit.

Press and keys to change the value.

3. Press to display the current data for the parameter Cn-00.

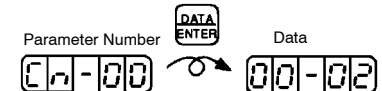

4. Press the and keys to change the data to 08.

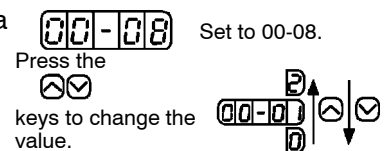

5. Press to select the current detection offset manual adjustment mode.

The amount of current detection offset is displayed.

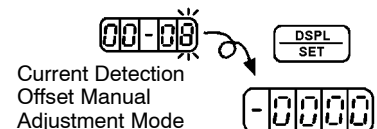

6. Press the and keys to switch between U-phase and V-phase current adjustment modes.

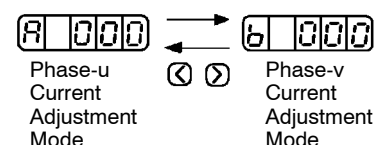

上正科技有限公司
 購買、維修 此手冊零組件
 電話：037-466333
 Email: service@repairtw.com
 Line id: @zzzz
 www.repairtw.com

- Press the and keys to adjust the amount of current detection offset.
- Press to return to the parameter data display.
- Press to return to the parameter setting mode display. This ends the current detection offset manual adjustment.

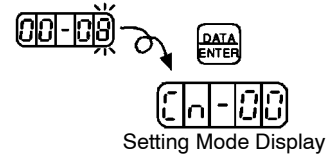
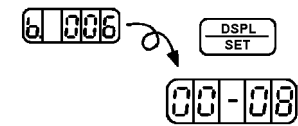
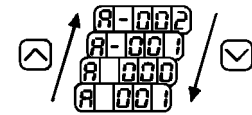

For JUSP-OP03A

- Press to select the parameter setting mode.
- Press the and to select the parameter number Cn-00. Parameter Cn-00 is selected when the power is turned ON.
- Press to display the current data for the parameter Cn-00.
- Press the and keys to change the data to 08.
- Press to select the current detection offset manual adjustment mode. The amount of current detection offset is displayed.
- Press to switch between U-phase and V-phase current adjustment modes.
- Press the and keys to adjust the amount of current detection offset.

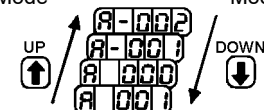
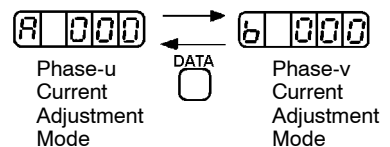
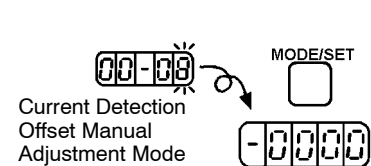
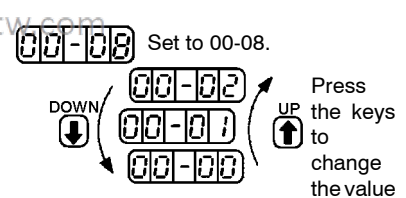
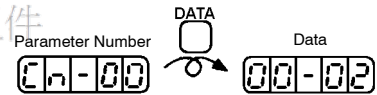
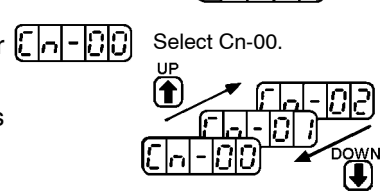
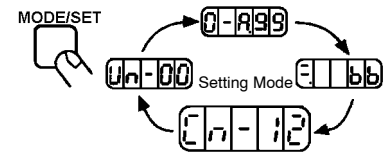

上正科技有限公司

購買、維修、此手冊電組件
電話：037-466333

Email: service@repairtw.com
Line id: @zzzz

www.repairtw.com

8. Press ^{MODE/SET} to return to the parameter data display.

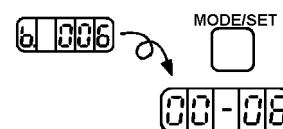

9. Press ^{DATA} to return to the parameter setting mode display. This ends the current detection offset manual adjustment.

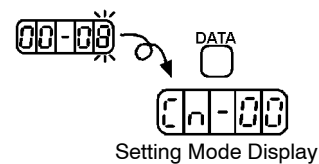

上正科技有限公司
 購買、維修 此手冊零組件
 電話： 037-466333
 Email: service@repairtw.com
 Line id: @zzzz
 www.repairtw.com

SERVO SELECTION AND DATA SHEETS

5

This chapter describes how to select Σ -Series servo drives and peripheral devices.

The section also presents the specifications and dimensional drawings required for selection and design.

Choose and carefully read the relevant sections of this chapter.

5.1	Selecting a Σ-Series Servo	223
5.1.1	Selecting a Servomotor	223
5.1.2	Selecting a SERVOPACK	233
5.1.3	Selecting a Digital Operator	235
5.2	SGM Servomotor	237
5.2.1	Ratings and Specifications	237
5.2.2	Mechanical Characteristics	269
5.2.3	Option Specifications	272
5.3	SERVOPACK Ratings and Specifications	282
5.3.1	Combined Specifications	282
5.3.2	Ratings and Specifications	285
5.3.3	Overload Characteristics	288
5.3.4	Starting Time and Stopping Time	289
5.3.5	Load Inertia	290
5.3.6	Overhanging Loads	291
5.4	Σ-Series Dimensional Drawings	292
5.4.1	Servomotor Dimensional Drawings	292
5.4.2	SERVOPACK Dimensional Drawings	400
5.4.3	Digital Operator Dimensional Drawings	412
5.5	Selecting Peripheral Devices	414
5.5.1	Selecting Peripheral Devices	414
5.5.2	Order List	424

5.6	Specifications and Dimensional Drawings of Peripheral Devices	442
5.6.1	Cable Specifications and Peripheral Devices	442
5.6.2	Motor Cables	446
5.6.3	Connector	447
5.6.4	Brake Power Supply	466
5.6.5	Encoder Cables	469
5.6.6	Battery for Absolute Encoder	480
5.6.7	1CN Connector	481
5.6.8	Connector Terminal Block Converter Unit	483
5.6.9	Cable With 1CN Connector and One End Without Connector	485
5.6.10	Circuit Breaker	486
5.6.11	Noise Filter	486
5.6.12	Magnetic Contactor	488
5.6.13	Surge Suppressor	490
5.6.14	Regenerative Resistor Unit	490
5.6.15	Variable Resistor for Speed Setting	491
5.6.16	Encoder Signal Converter Unit	492
5.6.17	Cables for Connecting PC and SERVOPACK	494

上正科技有限公司

購買、維修 此手冊零組件

電話： 037-466333

Email: service@repairtw.com

Line id: @zzzz

www.repairtw.com

5.1 Selecting a Σ -Series Servo

This section describes how to select the Σ -Series servomotor, SERVOPACK, and Digital Operator.

5.1.1 Selecting a Servomotor

Select an SGMG (1000 or 1500 min⁻¹), SGMS, or SGMD servomotor according to the servo system to be used. Each type can be identified as eight-digit alphanumeric characters following “SGMG-”, “SGMS-” or “SGMD-”. Numbers 1) to 6) shown in the following figure correspond to the numbers in the flowchart for servomotor selection on the following pages.

■ Selecting an SGMG, SGMS, or SGMD Servomotor

The following pages provide an explanation of Σ -Series Servomotor models and selection flowcharts.

上正科技有限公司
購買、維修 此手冊零組件
電話： 037-466333
Email: service@repairtw.com
Line id: @zzzz
www.repairtw.com

Models

Each model of Σ -Series Servomotor can be identified by specifying an 8-digit alphanumeric code following "SGM□-".

SGM□ - 03 A 2 A A □ □

Σ -Series _____

G: SGMG servomotor
S: SGMS servomotor
D: SGMD servomotor

1) Rated output (motor capacity) _____

03: 0.3kW (0.40HP) 05: 0.45kW (0.60HP) 06: 0.6kW (0.80HP)
09: 0.85kW(1.14HP), 0.9kW (1.21HP) 10: 1.0kW (1.34HP)
12: 1.2kW (1.61HP) 13: 1.3kW (1.74HP) 15: 1.5kW (2.01HP)
20: 1.8kW (2.41HP), 2.0kW (2.68HP) 22: 2.2kW (2.95HP)
30: 2.9kW (3.89HP), 3.0kW (4.02HP) 32: 3.2kW (4.29HP)
40: 4.0kW (5.36HP) 44: 4.4kW (5.90HP) 50: 5.0kW (6.71HP)
55: 5.5kW (7.38HP) 60: 6.0kW (8.05HP) 75: 7.5kW (10.06HP)
1A: 11kW (14.75HP) 1E: 15kW(20HP)

2) Supply voltage _____

A: 200V

3) Encoder specification _____

2: 8192 P/R incremental encoder
6: 4096 P/R incremental encoder
W: 12-bit (1024 P/R) absolute encoder
S: 15-bit (8192 P/R) absolute encoder

4) Rated speed _____

A: SGMG Type (1500 min⁻¹)
SGMS Type (3000 min⁻¹)
SGMD Type (2000 min⁻¹)
B: SGMG Type (1000 min⁻¹)

5) Shaft specification _____

Blank: Standard (straight without key)
A : Standard (straight without key, only when "options" and "lead specification" columns are not blank)
B : Straight with key and one shaft-end tap
C : Taper 1/10 with parallel key
D : Taper 1/10 with Woodruff key (for G Series 05 and 09 only)

6) Options _____

Blank: Standard
1 : Standard (only when "lead specification" column is not blank)
S : With shaft seal
B : With 90 VDC brake
C : With 24 VDC brake
F : With shaft seal and 90 VDC brake
G : With shaft seal and 24 VDC brake Options

Lead specification _____

Blank: Standard (connector)

上正科技有限公司
購買、維修 此手冊零組件
電話: 037-466333
Email: service@repairtw.com
line id: @z377
www.repairtw.com

Flowchart for servomotor selection

	Selected motor type
Example	SGMG- 0 9 A 2 A B S □
Axis 1	SGM□ - □ □ □ □ □ □ □ □
Axis 2	SGM□ - □ □ □ □ □ □ □ □
• • •	• • • • Blank for standard specification

Flowchart for Servomotor Selection

The actual selection of the SGMG, SGMS or SGMD servomotor is performed according to the following flowchart.

Flowchart for Servomotor Selection

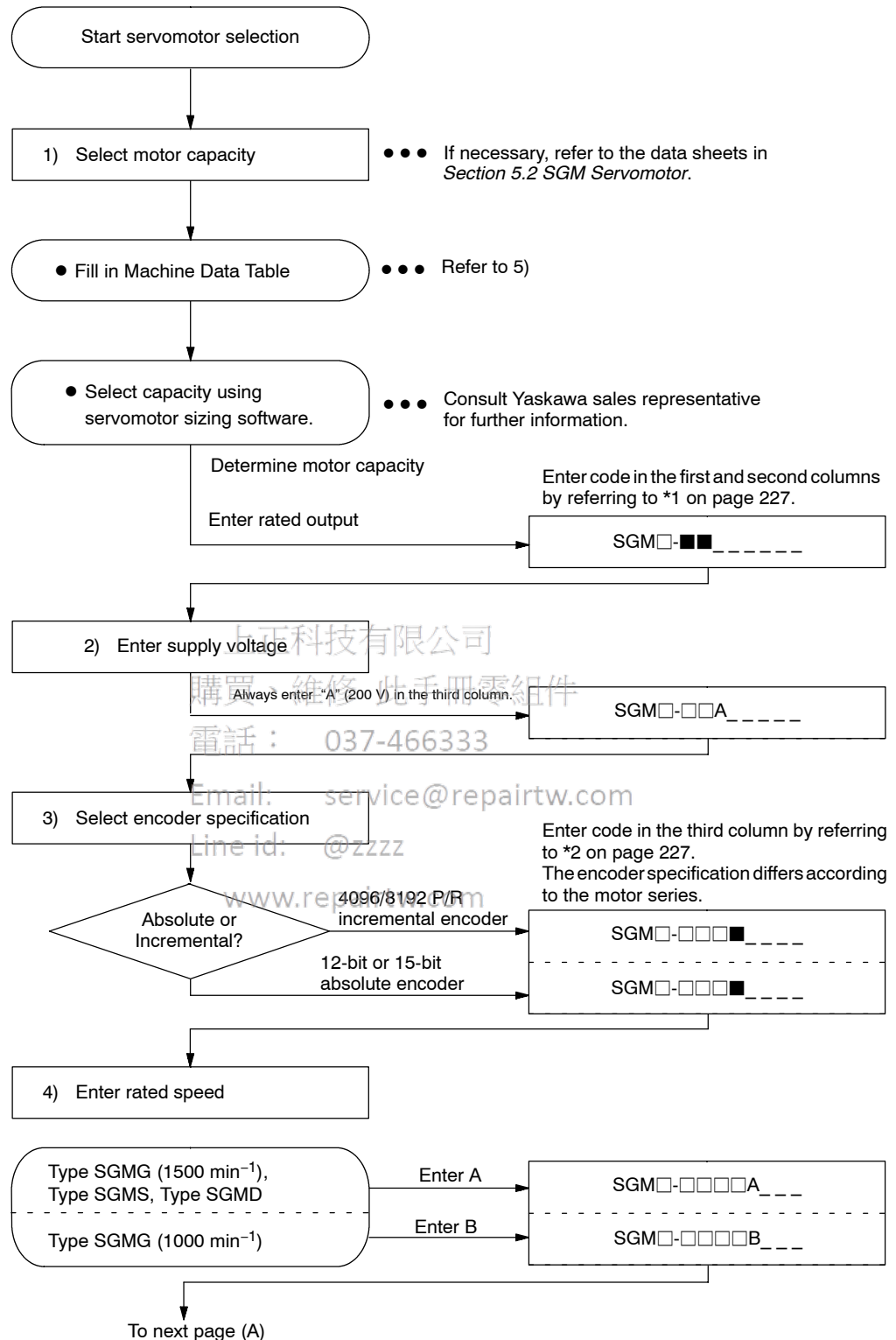

上海亞西電機有限公司
 購買、維修、此手冊電氣組件
 電話：037-466333
 Email: service@repairtw.com
 Line id: @zzzz
 www.repairtw.com

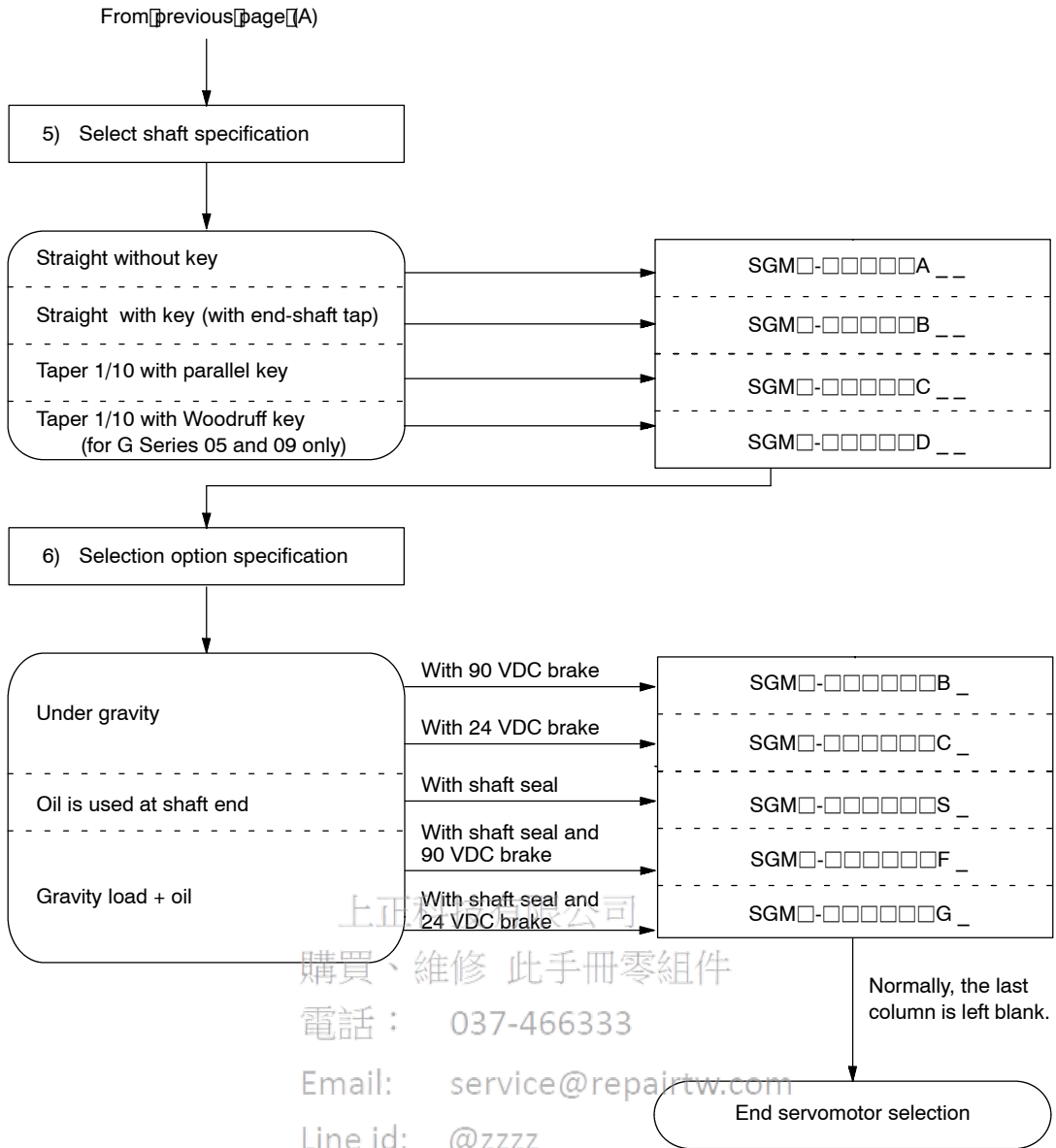

5

上正維修有限公司
 購買、維修 此手冊零組件
 電話： 037-466333
 Email: service@repairtw.com
 Line id: @zzzz
 www.repairtw.com

*1 Rated output (motor capacity)

KW(HP)

Code \ Series	G		S	D
	1500 min ⁻¹	1000 min ⁻¹	3000 min ⁻¹	2000 min ⁻¹
03		0.3 (0.40)		
05	0.45 (0.60)			
06		0.6 (0.80)		
09	0.85 (1.14)	0.9 (1.21)		
10			1.0 (1.34)	
12		1.2 (1.61)		
13	1.3 (1.74)			
15			1.5 (2.01)	
20	1.8 (2.41)	2.0 (2.68)	2.0 (2.68)	
22				2.2 (2.95)
30	2.9 (3.89)	3.0 (4.02)	3.0 (4.02)	
32				3.2 (4.29)
40			4.0 (5.36)	4.0 (5.36)
44	4.4 (5.90)	4.4 (5.90)		
50			5.0 (6.71)	
55	5.5 (7.38)			
60		6.0 (8.05)		
75	7.5 (10.06)			
1A	11.0 (14.75)			
1E	15.0 (20)			

5

購買、維修 此手冊零組件

*2 Encoder specification : 037-466333

Symbol	Specifications	SGMG	SGMS	SGMD
2	Incremental encoder: 8192 P/R	◎	○	○
6	Incremental encoder: 4096 P/R	○	◎	○
W	Absolute encoder: 12 bit (1024 P/R)	○	○	◎
S	Absolute encoder: 15 bit (8192 P/R)	○	○	○

◎: Standard

○: Non-standard

■ Selecting an SGMP-15A Servomotor

Select an SGMP-15A servomotor according to the servo system to be used. Each type can be identified as four-digit alphanumeric characters following "SGMP-15A". Numbers 1) to 6) shown in the following figure correspond to the numbers in the flowchart for servomotor selection on the following pages.

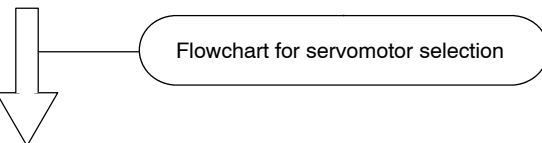
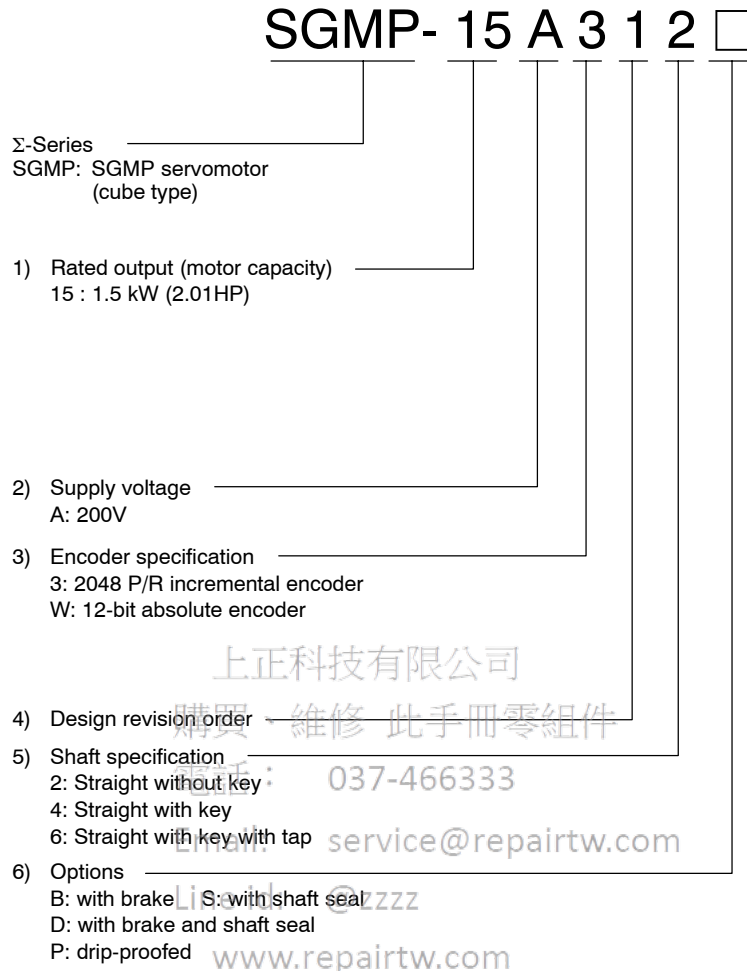

	Selected motor type
Example	SGMP- 1 5 A W 1 4 B
Axis 1	SGMP- □ □ □ □ □ □ □
Axis 2	SGMP- □ □ □ □ □ □ □
• • •	• • • • • •

Flowchart for Servomotor Selection

The actual selection of the SGMP-15A servomotor is conducted according to the following flowchart.

Flowchart for Servomotor Selection

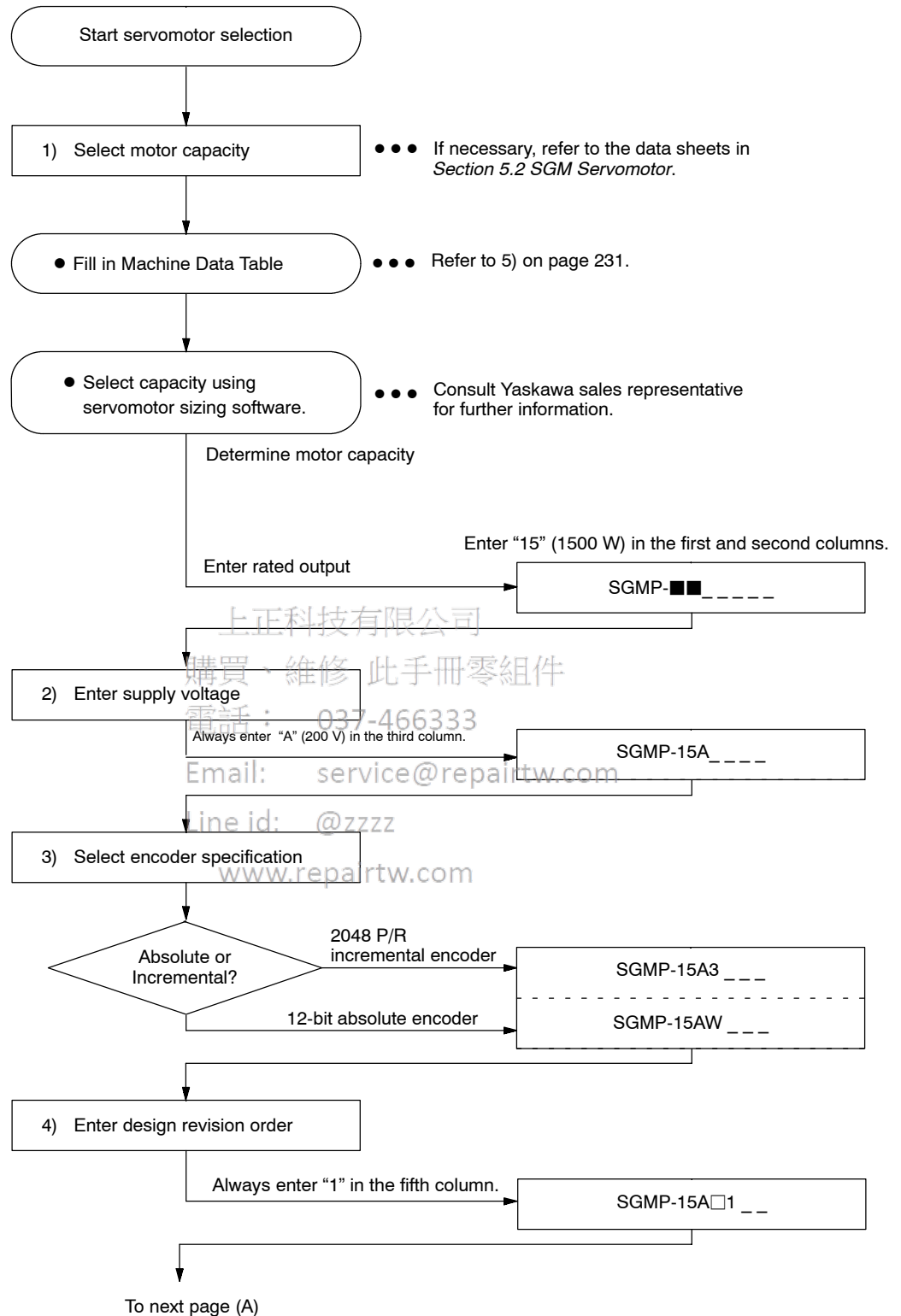

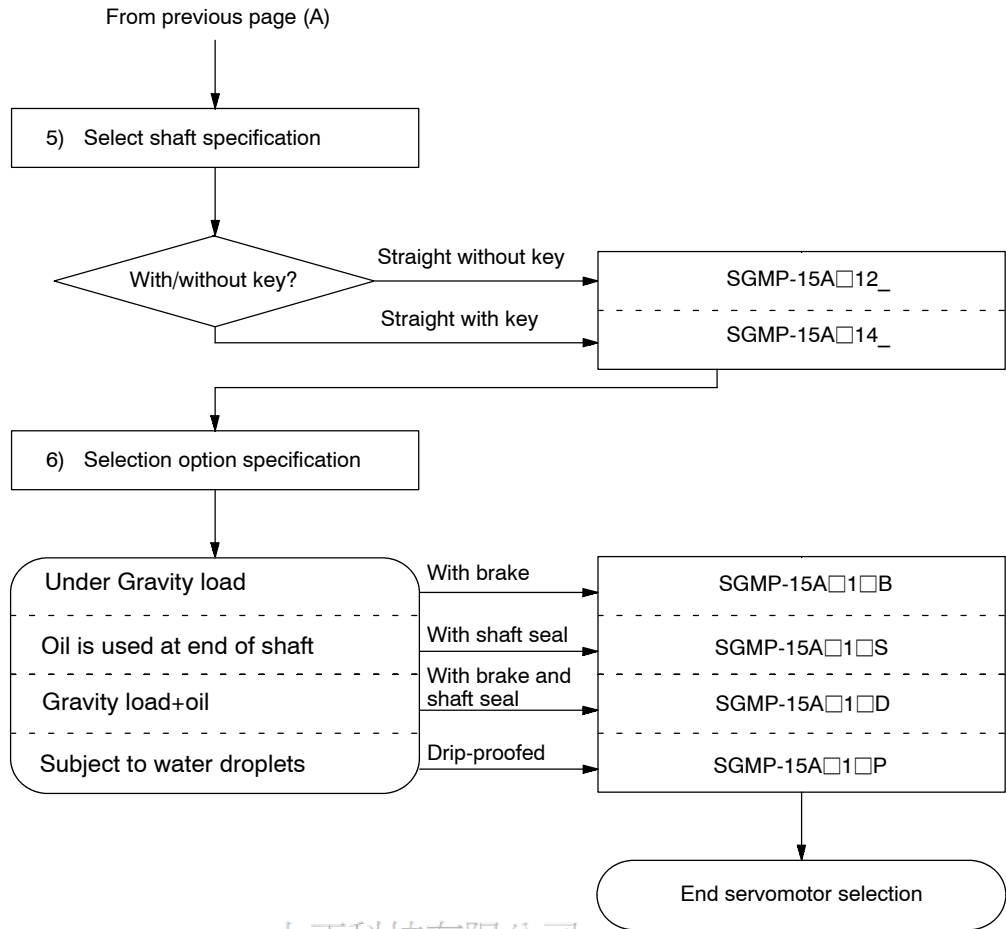

上正科技有限公司

購買、維修 此手冊零組件

電話： 037-466333

Email: service@repairtw.com

Line id: @zzzz

www.repairtw.com

Machine Data Table

Fill out the machine data table below as an aid to selecting the drive system. When the machine data table is complete, use the servomotor sizing software to select the motor capacity.

Ball Screw Horizontal Axis			
*1	Load mass	W —kg (lb)	
	Thrust	F —kg (lb)	
	Coefficient of friction	μ —	
	Overall efficiency	η —	
*2	Gear ratio	R (= Nm/NI) —	
*3	Gear+coupling	Jg —kg·cm ² (lb·in ² .)	
	Ball screw pitch	P —mm (in.)	
	Ball screw diameter	D —mm (in.)	
	Ball screw length	L —mm (in.)	
Ball Screw Vertical Axis			
	Load mass	W ₁ —kg (lb)	
	Counterweight	W ₂ —kg (lb)	
	Coefficient of friction	μ —	
	Overall efficiency	η —	
	Gear ratio	R (= Nm/NI) —	
	Gear+coupling	Jg —kg·cm ² (lb·in ² .)	
	Ball screw pitch	P —mm (in.)	
	Ball screw diameter	D —mm (in.)	
	Ball screw length	L —mm (in.)	
Timing Belt			
	Load mass	W —kg (lb)	
	Thrust	F —kg (lb)	
	Coefficient of friction	μ —	
	Overall efficiency	η —	
	Gear ratio	R (= Nm/NI) —	
	Gear+coupling	Jg —kg·cm ² (lb·in ² .)	
	Pulley	Jd —kg·cm ² (lb·in ² .)	
	Pulley diameter	D —mm (in.)	
Rack and Pinion			
	Load mass	W —kg (lb)	
	Thrust	F —kg (lb)	
	Coefficient of friction	μ —	
	Overall efficiency	η —	
	Gear ratio	R (= Nm/NI) —	
	Gear+coupling	Jg —kg·cm ² (lb·in ² .)	
	Pinion diameter	D —mm (in.)	
	Pinion thickness	t —mm (in.)	

USING THE DIGITAL OPERATOR

5.1.1 Selecting a Servomotor cont.

Roll Feeder			
Load J	$J\ell$	—kg·cm ² (lb·in ² .)	
Tension	F	—kg (lb)	
Press force	P	—kg (lb)	
Roller diameter	D	—mm (in.)	
Coefficient of friction	μ	—	
Overall efficiency	η	—	
Gear+coupling	Jg	—kg·cm ² (lb·in ² .)	
Rotor			
Load J	$J\ell$	—kg·cm ² (lb·in ² .)	
Load torque	$T\ell$	—kg·cm ² (lb·in ² .)	
Overall efficiency	η	—	
Gear+coupling	Jg	—kg·cm ² (lb·in ² .)	
Others			
Load J	$J\ell$	—kg·cm ² (lb·in ² .)	
Load torque	$T\ell$	—kg·cm ² (lb·in ² .)	
Motor speed	Nm	—min ⁻¹	
DUTY	td	—s	
Positioning time	ts	—s	
Accel/decel time	ta	—s	
Duty cycle			
DUTY	td	—s	
Positioning distance	Ls	—mm (in.)	
Moving member speed	$V\ell$	m/min	
Positioning time	ts	—s	
Accel/decel time	ta	—s	
Enter either $V\ell$ or ts . If both are entered, specify priority.			
Operating environment			
<ul style="list-style-type: none"> • Operating temperature • Other 			

*1 J (inertia) of Table W (load weight) and J (inertia) of the motor are automatically calculated by the servomotor sizing software.

*2 Gear ratio $R = Nm/N\ell = \text{motor-speed/load-speed}$

*3 Gear+coupling J g: J of gear or coupling
This is J of the joint (including a gear) between the motor and the load (machine).

5.1.2 Selecting a SERVOPACK

Select an SGDB SERVOPACK according to the servo system to be used. Each type can be identified as six-digit alphanumeric characters following "SGDB-".

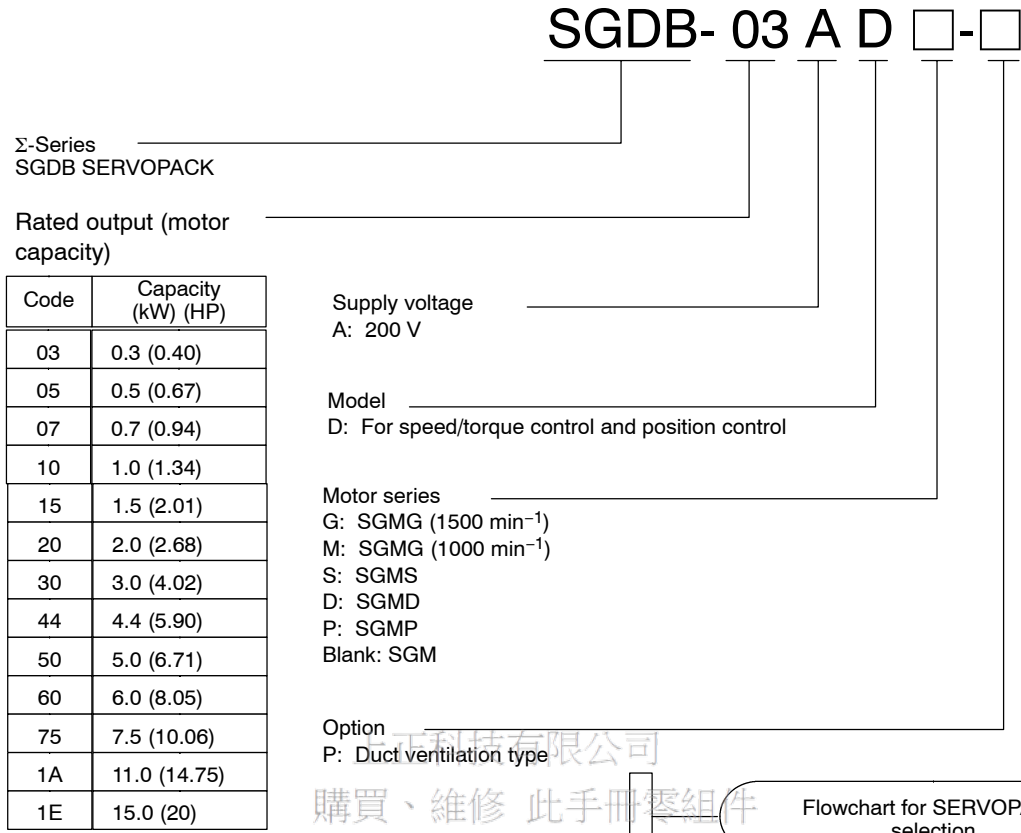

三井科技有限公司
 購買、維修 此手冊零組件
 電話： 037-466353
 Email: service@repairtw.com
 Line id: @zzzz

Flowchart for SERVOPACK selection

	Selected SERVOPACK type
Example	SGDB- 0 5 A D G
Axis 1	SGDB-
Axis 2	SGDB-
• • •	• • • • • •

* The motor type can be changed within the same group by altering the parameter setting. (See the table on the next page.)

Select an SGDB SERVOPACK according to the motor to be used. The following table shows the correspondence between SERVOPACK and motor types.

Group	SERVOPACK Type	Motor Type
05	SGDB-03ADM	SGMG-03A□B
	SGDB-05AD	SGM-04A
	SGDB-05ADP	SGMP-04A
	SGDB-05ADG	SGMG-05A□A
10	SGDB-07ADM	SGMG-06A□B
	SGDB-10AD	SGM-08A
	SGDB-10ADP	SGMP-08A
	SGDB-10ADG	SGMG-09A□A
	SGDB-10ADM	SGMG-09A□B
	SGDB-10ADS	SGMS-10A□A
15	SGDB-15ADM	SGMG-12A□B
	SGDB-15ADG	SGMG-13A□A
	SGDB-15ADP	SGMP-15A
	SGDB-15ADS	SGMS-15A□A
20	SGDB-20ADG	SGMG-20A□A
	SGDB-20ADM	SGMG-20A□B
	SGDB-20ADS	SGMS-20A□A
30	SGDB-30ADD	SGMD-22A□A
	SGDB-30ADG	SGMG-30A□A
	SGDB-30ADM	SGMG-30A□B
	SGDB-30ADS	SGMS-30A□A
44	SGDB-44ADD	SGMD-32A□A
	SGDB-44ADG	SGMG-44A□A
	SGDB-44ADM	SGMG-44A□B
	SGDB-44ADS	SGMS-40A□A
	SGDB-50ADD	SGMD-40A□A
60	SGDB-50ADS	SGMS-50A□A
	SGDB-60ADG	SGMG-55A□A
75	SGDB-60ADM	SGMG-60A□B
1A	SGDB-75ADG	SGMG-75A□A
1E	SGDB-1AADG	SGMG-1AA□A
	SGDB-1EADG	SGMG-1EA□A



The motor type can be changed within the same group by altering the parameter setting.

5.1.3 Selecting a Digital Operator

The following two types of Digital Operator are available.

The two types cannot be used simultaneously. However, it is convenient to have both types and use whichever suits the circumstances.

Each type differs in shape but the operating functions are identical.

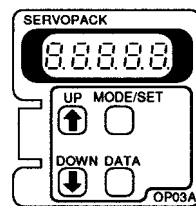

JUSP-OP03A (Mount Type)

- Use attached to the top of the SERVOPACK front face.

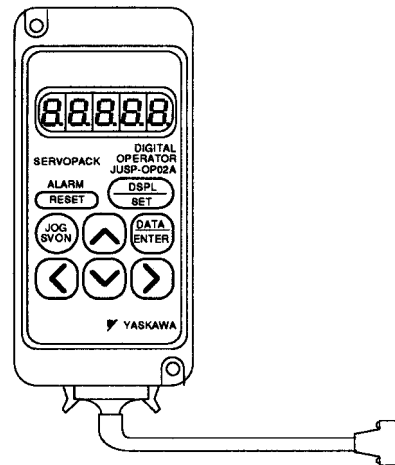

JUSP-OP02A-1 (Hand-held Type)

- Use held in the hand while connected with the 1 m cable supplied.

上正科技有限公司

購買、維修 此手冊零組件

電話： 037-466333

Email: service@repairtw.com

Line id: @zzzz

www.repairtw.com

The Digital Operator is selected according to the flowchart below.

Flowchart for Digital Operator Selection

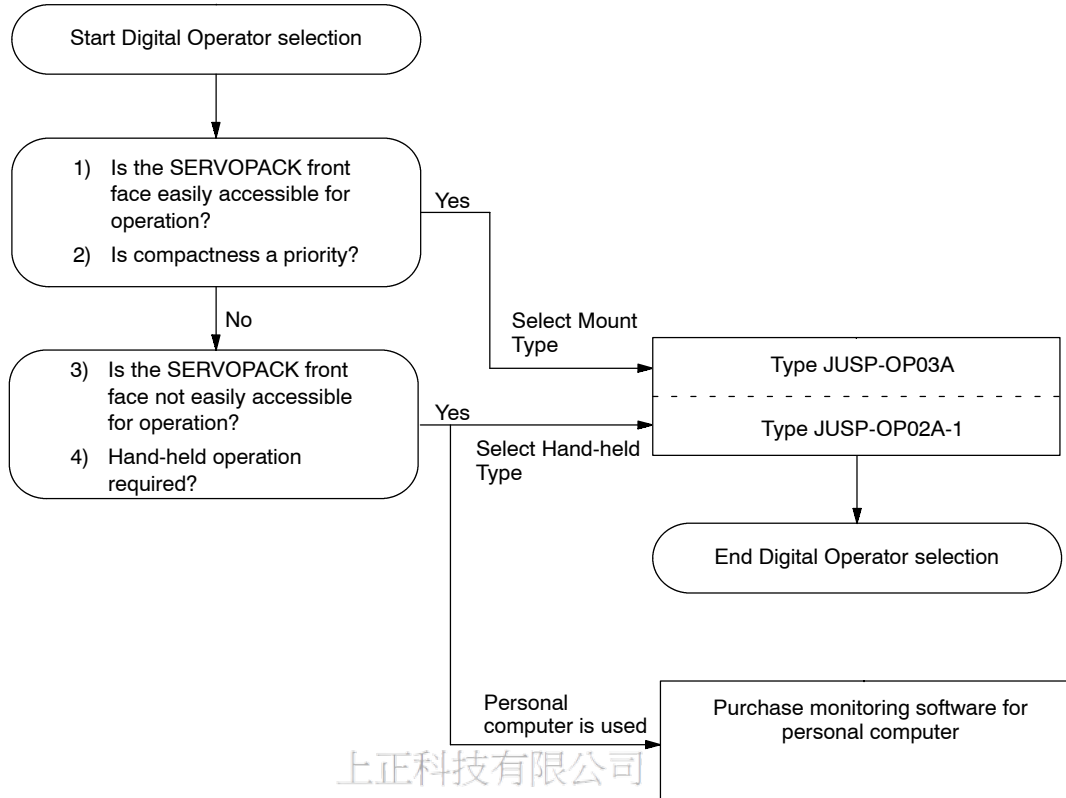

上正科技有限公司

購買、維修 此手冊零件
Separately purchase dedicated cable (DE9405258).

電話： 037-466333

Email: service@repairtw.com

Line id: @zzzz

www.repairtw.com

5.2 SGM Servomotor

This section presents tables of ratings and specifications for SGMG, SGMS, SGMD and SGMP servomotors. Refer to these tables when selecting a servomotor. For SGM(400W, 750W) and SGMP(400W, 750W) servomotor, refer to USER'S MANUAL(manual No. TSE-S800-15 or TSE-S800-17).

5.2.1 Ratings and Specifications

Ratings and Specifications of each servomotor model are shown below.

- SGMG Servomotors (Rated Motor Speed is 1500 min⁻¹)

Ratings and Specifications

Time rating:	continuous
Thermal class:	F
Vibration class:	15 μ m or below
Withstand voltage:	1500 VAC
Insulation resistance:	500 VDC 10M Ω min.
Enclosure:	totally enclosed, self-cooled IP67(except for shaft opening)
Ambient temperature:	0 to 40°C
Ambient humidity:	20% to 80% (non-condensing)
Excitation:	permanent magnet
Drive method:	direct drive
Mounting:	flange method

Email: service@repairtw.com

Line id: @zzzz

www.repairtw.com

USING THE DIGITAL OPERATOR

5.2.1 Ratings and Specifications cont.

Servomotor SGMG		05A□A	09A□A	13A□A	20A□A	30A□A	44A□A	55A□A	75A□A	1AA□A	1EA□A
Rated Output*	kW (HP)	0.45 (0.6)	0.85 (1.1)	1.3 (1.7)	1.8 (2.4)	2.9 (3.9)	4.4 (5.9)	5.5 (7.4)	7.5 (10)	11 (15)	15 (20)
	N·m	2.84	5.39	8.34	11.5	18.6	28.4	35.0	48.0	70.0	95.4
Rated Torque*	kgf·cm (lb·in)	29 (25)	55 (48)	85 (74)	117 (102)	190 (165)	290 (252)	357 (310)	490 (425)	714 (620)	974 (845)
	N·m	8.92	13.8	23.3	28.7	45.1	71.1	87.6	119	175	224
Instantaneous Peak Torque*	kgf·cm (lb·in)	91 (79)	141 (122)	238 (207)	293 (254)	460 (404)	725 (630)	894 (775)	1210 (1050)	1790 (1550)	2290 (1988)
	A (rms)	3.8	7.1	10.7	16.7	23.8	32.8	42.1	54.7	58.6	78.0
Instantaneous Max Current*	A (rms)	11	17	28	42	56	84	110	130	140	170
Rated Speed*	min ⁻¹	1500									
Instantaneous Max Speed*	min ⁻¹	3000									2000
Torque Constant	N·m/A (rms)	0.82	0.83	0.84	0.73	0.83	0.91	0.88	0.93	1.25	1.32
	lb·in/A (rms)	7.3	7.3	7.4	6.5	7.3	8.0	7.8	8.2	11	11.7
Moment of Inertia	× 10 ⁻⁴ kg·m ²	7.24	13.9	20.5	31.7	46.0	67.5	89.0	125	281	315
	× 10 ⁻³ lb·in·s ²	6.41	12.3	18.2	28.1	40.7	59.8	78.8	111	249	279
Rated Power Rate*	kW/s	11.2	20.9	33.8	41.5	75.3	120	137	184	174	289
Rated Angular Acceleration*	rad/s ²	3930	3880	4060	3620	4050	4210	3930	3850	2490	3030
Inertia Time Constant	ms	5.0	3.1	2.8	2.1	1.9	1.3	1.3	1.1	1.2	0.98
Inductive Time Constant	ms	5.1	5.3	6.3	12.5	12.5	15.7	16.4	18.4	22.6	27.2

* These items and torque-speed characteristics quoted in combination with an SGDB SER-VOPACK at an armature winding temperature of 20°C.

Note These characteristics can be obtained when the following heat sinks (steel plates) are used for cooling purposes:

Type 05A□A to 13A□A : 400×400×20 (mm) (15.75×15.75×0.79 (in))

Type 20A□A to 75A□A : 550×550×30 (mm) (21.65×21.65×1.18 (in))

Type 1AA□A to 1EA□A : 650×650×35 (mm) (25.59×25.59×1.38 (in))

NOTE The ratings and specifications above refer to a standard servomotor.

Add the numerical values below to the moment of inertia values in the table for a motor fitted with a **holding brake**.

Other specifications will also change slightly.

Servomotor SGMG			05A□ A	09A□ A	13A□ A	20A□ A	30A□ A	44A□ A	55A□ A	75A□ A	1AA □A	1EA□ A	
Holding brake 90VDC	Moment of Inertia Increase	$\times 10^{-4}$ kg·m ²	2.1			8.5			8.5			18.8	37.5
		$\times 10^{-3}$ lb·in·s ²	1.86			7.54			7.54			16.7	33.2
	Static Friction Torque	N·m	4.41	12.7	43.1			72.6			84.3	114.7	

上正科技有限公司

購買、維修 此手冊零組件

電話： 037-466333

Email: service@repairtw.com

Line id: @zzzz

www.repairtw.com

5



Holding Brake

The holding brake is automatically applied to the motor shaft to prevent the load falling in vertical axis applications when the motor power supply is turned off or fails. It is only to hold the load and cannot be used for stopping the motor.

Torque-Motor Speed Characteristics

• SGMG-05A□A

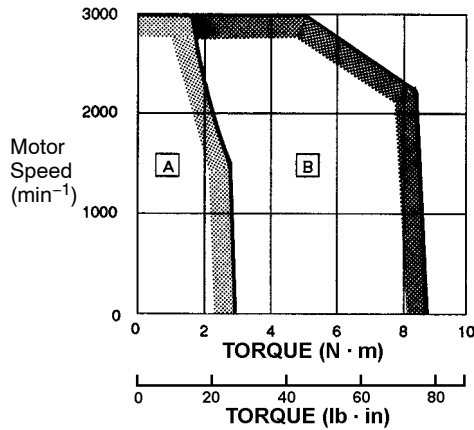

• SGMG-09A□A

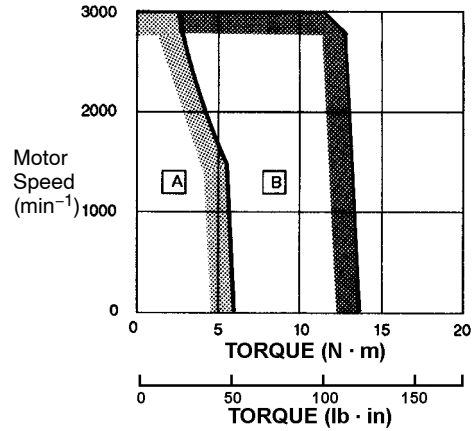

• SGMG-13A□A

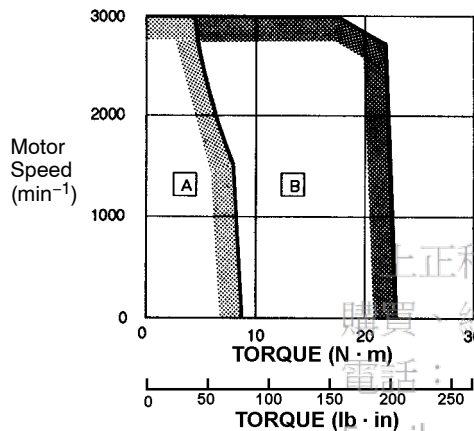

• SGMG-20A□A

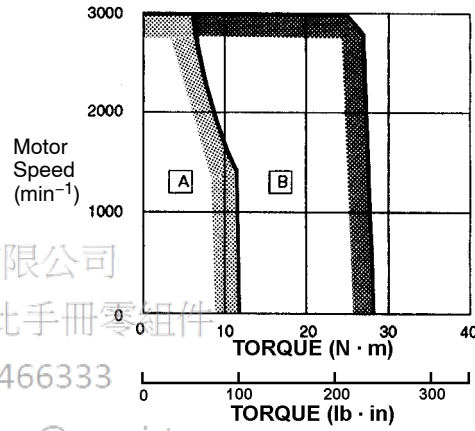

• SGMG-30A□A

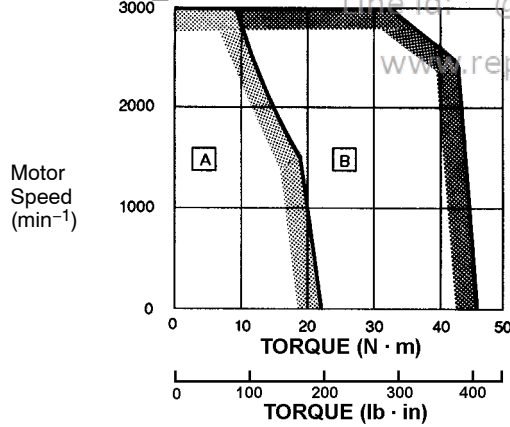

• SGMG-44A□A

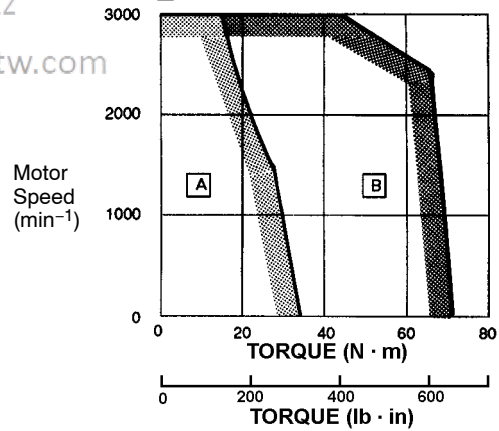

A: Continuous Duty Zone
B: Intermittent Duty Zone

• SGMG-55A□A

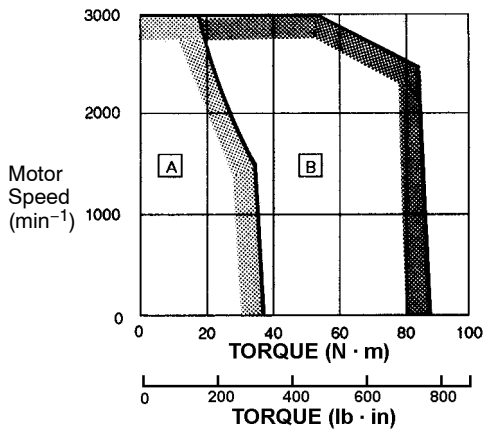

• SGMG-75A□A

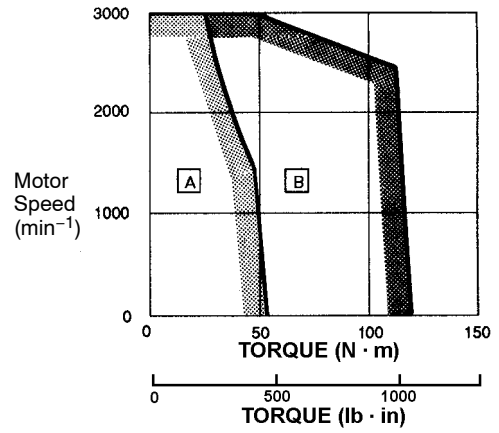

• SGMG-1AA□A

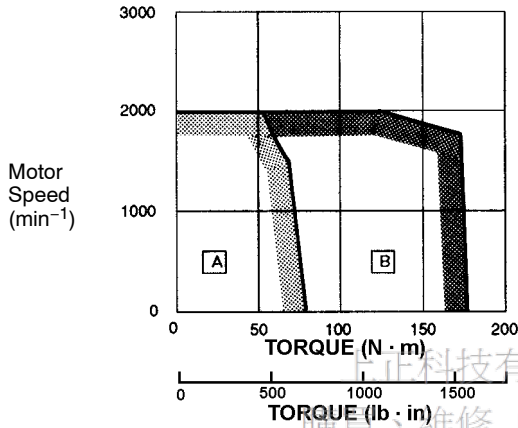

• SGMG-1EA□A

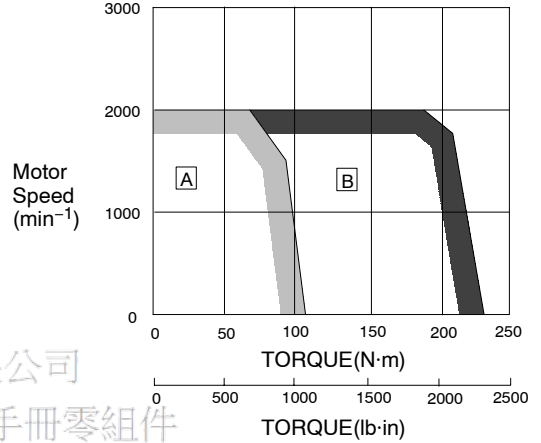

A: Continuous Duty Zone
B: Intermittent Duty Zone

www.repairtw.com

■ SGMG Servomotors with Standard Backlash Gears (Rated Motor Speed is 1500 min⁻¹)

Ratings and Specifications

Time rating:	continuous
Thermal class:	F
Vibration class:	15µm or below
Withstand voltage:	1500 VAC for one minute
Insulation resistance:	500 VDC 10MΩ min.
Enclosure:	totally enclosed, self-cooled IP44 (or the equivalent)
Ambient temperature:	0 to 40°C
Ambient humidity:	20% to 80% (non-condensing)
Excitation:	permanent magnet
Drive method:	direct drive
Mounting:	foot and flange mounted Type 4095 to 4115: omni-directional mounting Type 4130 to 4190 horizontal mounting to shaft
Rotation direction:	reverse
Gear lubricating method:	Type 4095 to 4115: grease Type 4130 to 4190: oil *
Gear mechanism:	planetary gear mechanism
Backlash:	roughly 0.6 to 2° at the gear output shaft

* For oil lubrication, the motor should be mounted horizontal to the shaft. Contact your Yaskawa representative about lubrication for mounting at angles.

5

Servomotor Model SGMG-	Servomotor			Gear				Gear Inertia × 10 ⁻⁴ Kg·m ² (× 10 ⁻³ lb·in·s ²)	
	Output kW	Rated Speed min ⁻¹	Rated Torque N·m (lb·in)	Gear Ratio	Rated Torque/Efficiency N·m/% (lb·in/%)	Instantaneous Peak Torque/Efficiency N·m/% (lb·in/%)	Rated Speed min ⁻¹		Max. Speed min ⁻¹
-05A□A□AR	0.45	1500	2.84 (25)	1/6	13.6/80 (120/80)	42.8/80 (379/80)	250	500	1.96 (1.73)
-05A□A□BR				1/11	25.0/80 (221/80)	78.5/80 (695/80)	136	272	1.6 (1.42)
-05A□A□CR				1/21	44.8/70 (397/70)	140/75 (1239/75)	71	142	1.15 (1.02)
-05A□A□7R				1/29	66.0/80 (584/80)	207/80 (1832/80)	51	103	1.17 (1.04)
-09A□A□AR	0.85		5.39 (48)	1/6	25.9/80 (229/80)	66.3/80 (587/80)	250	500	1.8 (1.59)
-09A□A□BR				1/11	47.4/80 (420/80)	122/80 (1080/80)	136	272	1.4 (1.24)
-09A□A□CR				1/21	79.3/70 (702/70)	203/70 (1797/70)	71	142	2.0 (1.77)
-09A□A□7R				1/29	125/75 (1106/75)	321/80 (2841/80)	51	103	2.2 (1.95)

Servomotor Model SGMG-	Servomotor			Gear					Gear Inertia × 10 ⁻⁴ Kg·m ² (× 10 ⁻³ lb·in·s ²)
	Output kW	Rated Speed min ⁻¹	Rated Torque N·m (lb·in)	Gear Ratio	Rated Torque/Efficiency N·m/% (lb·in/%)	Instantaneous Peak Torque/Efficiency N·m/% (lb·in/%)	Rated Speed min ⁻¹	Max. Speed min ⁻¹	
-13A□A□AR	1.3	1500	8.34 (74)	1/6	40.0/80 (354/80)	112/80 (991/80)	250	500	1.8 (1.59)
-13A□A□BR				1/11	68.7/80 (608/80)	192/75 (1699/75)	136	272	2.9 (2.57)
-13A□A□CR				1/21	140/75 (1239/75)	392/80 (3470/80)	71	142	2.0 (1.77)
-13A□A□7R				1/29	193/80 (1708/80)	541/80 (4788/80)	51	103	0.9 (0.797)
-20A□A□AR	1.8		11.5 (102)	1/6	55.1/80 (488/80)	138/80 (1221/80)	250	500	6.3 (5.58)
-20A□A□BR				1/11	101/80 (894/80)	253/80 (2239/80)	136	272	4.8 (4.25)
-20A□A□CR				1/21	193/75 (1708/75)	482/80 (4266/80)	71	142	5.9 (5.22)
-20A□A□7R				1/29	266/80 (2354/80)	666/80 (5895/80)	51	103	5.6 (4.96)
-30A□A□AR	2.9		18.6 (165)	1/6	89.4/80 (791/80)	217/80 (1921/80)	250	500	6.3 (5.58)
-30A□A□BR				1/11	164/80 (1452/80)	397/80 (3514/80)	136	272	4.8 (4.25)
-30A□A□CR				1/21	313/80 (2770/80)	758/80 (6709/80)	71	142	5.9 (5.22)
-30A□A□7R				1/29	432/75 (3824/75)	1049/80 (9285/80)	51	103	45.9 (40.6)
-44A□A□AR	4.4		28.4 (252)	1/6	136/80 (1204/80)	341/80 (3018/80)	250	500	12.0 (10.6)
-44A□A□BR				1/11	250/80 (2213/80)	625/80 (5532/80)	136	272	7.7 (6.82)
-44A□A□CR				1/21	477/80 (4222/80)	1196/80 (10586/80)	71	142	47.5 (42.0)
-44A□A□7R				1/29	660/80 (5842/80)	1646/80 (14569/80)	51	103	63.5 (56.2)
-55A□A□AR	5.5		35.0 (310)	1/6	168/80 (1487/80)	420/80 (3717/80)	250	500	14.0 (12.4)
-55A□A□BR				1/11	308/80 (2726/80)	771/80 (6824)	136	272	9.8 (8.67)
-55A□A□CR				1/21	588/80 (5204/80)	1470/80 (13011/80)	71	142	79.0 (69.9)
-55A□A□7R				1/29	811/80 (7178/80)	2029/80 (17959/80)	51	103	77.0 (68.2)

USING THE DIGITAL OPERATOR

5.2.1 Ratings and Specifications cont.

Servomotor Model SGMG-	Servomotor			Gear					Gear Inertia × 10 ⁻⁴ Kg·m ² (× 10 ⁻³ lb·in·s ²)
	Output kW	Rated Speed min ⁻¹	Rated Torque N·m (lb·in)	Gear Ratio	Rated Torque/Efficiency N·m/% (lb·in/%)	Instantaneous Peak Torque/Efficiency N·m/% (lb·in/%)	Rated Speed min ⁻¹	Max. Speed min ⁻¹	
-75A□A□BR	7.5	1500	48.0 (425)	1/11	422/80 (3735/80)	1039/80 (9196/80)	136	272	65.0 (57.5)
-75A□A□CR				1/21	807/80 (7143/80)	1989/80 (17605/80)	71	142	79.0 (69.9)
-75A□A□7R				1/29	1117/80 (9887/80)	2754/80 (24376/80)	51	103	91.0 (80.5)
-1AA□A□BR	11	1500	70.0 (620)	1/11	615/80 (5443/80)	1548/80 (13701/80)	136	182	90.0 (79.6)
-1AA□A□CR				1/21	1176/80 (10408/80)	2950/80 (26110/80)	71	95	95.0 (84.1)
-1AA□A□7R				1/29	1627/80 (14400/80)	4067/80 (35996/80)	51	69	238.0 (210.6)

Note Output torque and motor speed produce the following trends in efficiency. Values in the table are at the rated motor speed.

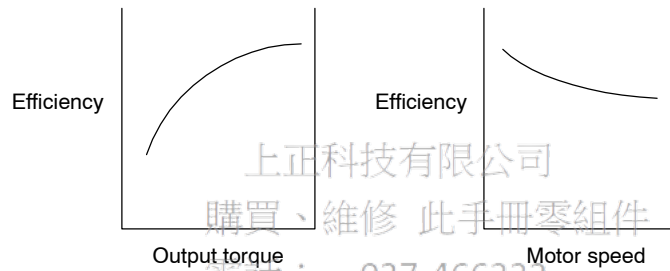

5

Configuration

The following configuration accurately and efficiently transmits Servomotor power.

A gear (Cyclo) is used in combination with the internal planetary gear mechanism of the Servomotor.

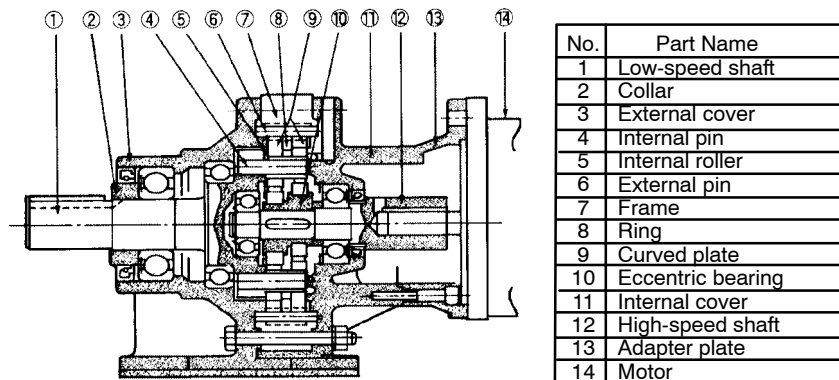

Gear Lubrication

• Grease Lubricating Type (4095 to 4115)

The gearbox is filled at the factory.

• Oil Lubricating Type (4130 to 4190)

All oil is drained from the gears prior to shipment. The gearbox must be filled to the red line at the top of the oil gauge before initial use.

We recommend using industrial extreme-pressure gear oil or SP type or JIS K 2219 industrial gear oil type 2 or equivalent. See the following table.

Ambient Temperature C°	Manufacturer		
	Kosmo Oil Co., Ltd.	Nihon Sekiyu Co., Ltd.	General Oil Co. Ltd.
0 to 35°C	Kosmo Gear Co., Ltd. SE 100, 150	Bonokku M 100, 150	General SP Gear Roll 100, 150

Approximate amounts of oil are shown in the following table.

(Unit: 1 [liters])

Frame No.	4130 4135	4145	4155	4160 4165	4170 4175	4180 4185	4190
Horizontal Type	0.7	0.7	0.7	1.4	1.9	2.5	4.0

5

■ SGMG Servomotors with Low-backlash Gears (Rated Motor Speed is 1500 min⁻¹)

Ratings and Specifications

Time rating:	continuous
Thermal class:	F
Vibration class:	15μm or below
Withstand voltage:	1500 VAC for one minute
Insulation resistance:	500 VDC 10MΩ min.
Enclosure:	totally enclosed, self-cooled IP44 (or the equivalent)
Ambient temperature:	0 to 40°C
Ambient humidity:	20% to 80% (non-condensing)
Excitation:	permanent magnet
Drive method:	direct drive
Mounting:	flange mounted (can be mounted in any direction)
Rotation direction:	forward
Gear lubricating method:	grease
Gear mechanism:	planetary gear mechanism
Backlash:	0.05° (3 min) at the gear output shaft

USING THE DIGITAL OPERATOR

5.2.1 Ratings and Specifications cont.

Servomotor Model SGMG-	Servomotor			Gear					Gear Inertia $\times 10^{-4}$ kg·m ² ($\times 10^{-3}$ lb·in·s ²)	Load Inertia at the Motor Shaft (Servomotor + Gear) $\times 10^{-4}$ kg·m ² ($\times 10^{-3}$ lb·in·s ²)
	Output kW	Rated Speed min ⁻¹	Rated Torque N·m (lb·in)	Gear Ratio	Rated Torque/Efficiency N·m/% (lb·in/%)	Instantaneous Peak Torque/Efficiency N·m/% (lb·in/%)	Rated Speed min ⁻¹	Max. Speed min ⁻¹		
-05A□AL1K	0.45	1500	2.84 (25)	1/5	11.4/80 (101/80)	35.7/80 (316/80)	300	600	1.26 (1.12)	8.50 (7.52)
-05A□AL2K				1/9	20.4/80 (181/80)	64.2/80 (568/80)	167	334	0.94 (0.832)	8.18 (7.24)
-05A□AL5K				1/20	45.4/80 (402/80)	143/80 (1266/80)	75	150	4.66 (4.12)	11.9 (10.5)
-05A□AL7K				1/29	65.9/80 (583/80)	207/80 (1832/80)	51	102	2.76 (2.44)	10.0 (8.85)
-05A□AL8K				1/45	102/80 (903/80)	321/80 (2841/80)	33	66	1.81 (1.60)	9.05 (8.0)
-09A□AL1K	0.85		5.39 (48)	1/5	21.6/80 (191/80)	55.2/80 (489/80)	300	600	1.30 (1.15)	15.2 (13.5)
-09A□AL2K				1/9	38.8/80 (343/80)	74.5/60 (659/60)	167	334	0.90 (0.797)	14.8 (13.1)
-09A□AL5K				1/20	86.2/80 (763/80)	221/80 (1956/80)	75	150	4.70 (4.16)	18.6 (16.5)
-09A□AL7K				1/29	125/80 (1106/80)	320/80 (2832/80)	51	102	2.80 (2.48)	16.7 (14.8)
-09A□AL8K				1/45	194/80 (1717/80)	497/80 (4399/80)	33	66	4.50 (3.98)	18.4 (16.3)
-13A□AL1K	1.3		8.34 (74)	1/5	33.4/80 (296/80)	93.2/80 (825/80)	300	600	7.20 (6.37)	27.7 (24.5)
-13A□AL2K				1/9	60.0/80 (531/80)	168/80 (1487/80)	167	334	4.80 (4.25)	25.3 (22.4)
-13A□AL5K				1/20	133/80 (1177/80)	373/80 (3301/80)	75	150	6.90 (6.11)	27.4 (24.3)
-13A□AL7K				1/29	193/80 (1708/80)	541/80 (4788/80)	51	102	10.4 (9.21)	30.9 (27.3)
-13A□AL8K				1/45	300/80 (2655/80)	839/80 (7426/80)	33	66	6.70 (5.93)	27.2 (24.1)

5

Servomotor Model SGMG-	Servomotor			Gear					Gear Inertia $\times 10^{-4}$ kg·m ² ($\times 10^{-3}$ lb·in·s ²)	Load Inertia at the Motor Shaft (Servomotor + Gear) $\times 10^{-4}$ kg·m ² ($\times 10^{-3}$ lb·in·s ²)
	Output kW	Rated Speed min ⁻¹	Rated Torque N·m (lb·in)	Gear Ratio	Rated Torque/Efficiency N·m/% (lb·in/%)	Instantaneous Peak Torque/Efficiency N·m/% (lb·in/%)	Rated Speed min ⁻¹	Max. Speed min ⁻¹		
-20A□AL1K	1.8	1500	11.5 (102)	1/5	46.0/80 (407/80)	115/80 (1018/80)	300	600	10.2 (9.03)	41.9 (37.1)
-20A□AL2K				1/9	82.8/80 (733/80)	207/80 (1832/80)	167	334	7.80 (6.90)	39.5 (35.0)
-20A□AL5K				1/20	184/80 (1629/80)	459/80 (4063/80)	75	150	20.2 (17.9)	51.9 (45.9)
-20A□AL7K				1/29	267/80 (2363/80)	666/80 (5895/80)	51	102	13.4 (11.9)	45.1 (39.9)
-30A□AL1K	2.9	1500	18.6 (165)	1/5	74.4/80 (659/80)	182/80 (1611/80)	300	600	20.4 (18.1)	66.4 (58.8)
-30A□AL2K				1/9	134/80 (1186/80)	328/80 (2903/80)	167	334	12.5 (11.1)	58.5 (51.8)
-30A□AL5K				1/20	298/80 (2638/80)	730/80 (6461/80)	75	150	20.2 (17.9)	66.2 (58.6)
-44A□AL1K	4.4	1500	28.4 (251)	1/5	114/80 (1009/80)	284/80 (2514/80)	300	600	20.4 (18.1)	87.9 (77.8)
-44A□AL2K				1/9	204/80 (1806/80)	512/80 (4532/80)	167	334	12.5 (11.1)	80.0 (70.8)

Note Output torque and motor speed produce the following trends in efficiency. Values in the table are at the rated motor speed.



Configuration

This simple planetary gear mechanism is equipped with four planetary gears to which load is evenly distributed via a floating relay ring in each step.

Two gears are used to transmit driving force during forward rotation, and the other two are used to transmit driving force during reverse rotation.

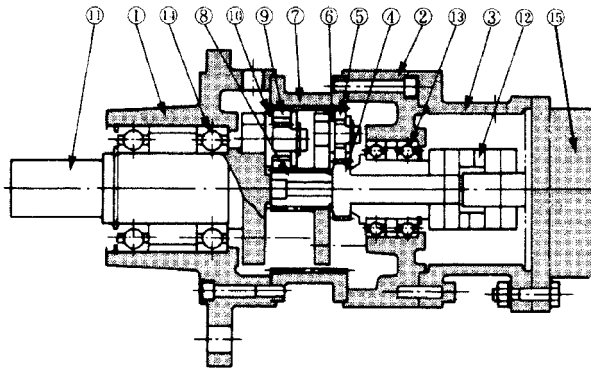

No.	Part Name
1	Casing
2	Bracket
3	Motor bracket
4	Primary sun gear
5	Primary planetary gear
6	Primary planetary shaft
7	Internal gear
8	Secondary sun gear
9	Secondary planetary gear
10	Secondary planetary shaft
11	Low-speed shaft
12	Oldham's coupling
13	High-speed shaft bearing
14	Low-speed shaft bearing
15	Motor

Gear Lubrication

The gearbox is filled at the factory.

上正科技有限公司

購買、維修 此手冊零組件

電話： 037-466333

Email: service@repairtw.com

Line id: @zzzz

www.repairtw.com

■ SGMG Servomotors (Rated Motor Speed is 1000 min⁻¹)

Ratings and Specifications

Time rating:	continuous
Thermal class:	F
Vibration class:	15µm or below
Withstand voltage:	1500 VAC
Insulation resistance:	500 VDC 10MΩ min.
Enclosure:	totally enclosed, self-cooled IP67 (except for shaft opening)
Ambient temperature:	0 to 40°C
Ambient humidity:	20% to 80% (non-condensing)
Excitation:	permanent magnet
Drive method:	direct drive
Mounting:	flange method

Servomotor SGMG		03A□B	06A□B	09A□B	12A□B	20A□B	30A□B	44A□B	60A□B
Rated Output*	kW (HP)	0.3 (0.4)	0.6 (0.8)	0.9 (1.2)	1.2 (1.6)	2.0 (2.7)	3.0 (4.0)	4.4 (5.9)	6.0 (8.0)
Rated Torque *	N·m	2.84	5.68	8.62	11.5	19.1	28.4	41.9	57.2
	lb·in	25	50	76	102	169	252	372	508
Instantaneous Peak Torque*	N·m	7.17	14.1	19.3	28.0	44.0	63.7	107	129
	lb·in	63	125	171	248	390	564	947	1140
Rated Current*	A (rms)	3.0	5.7	7.6	11.6	18.5	24.8	32.9	46.9
Instantaneous Max Current*	A (rms)	7.3	13.9	16.6	28	42	56	84	110
Rated Speed*	min ⁻¹	1000							
Instantaneous Max Speed*	min ⁻¹	2000							
Torque Constant	N·m/A (rms)	1.03	1.06	1.21	1.03	1.07	1.19	1.34	1.26
	lb·in/A (rms)	9.12	9.38	10.7	9.12	9.47	10.5	11.9	11.2
Moment of Inertia	× 10 ⁻⁴ kg·m ²	7.24	13.9	20.5	31.7	46.0	67.5	89.0	125
	× 10 ⁻³ lb·in·s ²	6.41	12.3	18.2	28.1	40.7	59.8	78.8	111
Rated Power Rate*	kW/s	11.2	23.2	36.3	41.5	79.4	120	198	262
Rated Angular Acceleration*	rad/s ²	3930	4080	4210	3620	4150	4210	4710	4590
Inertia Time Constant	ms	5.1	3.8	2.8	2.0	1.7	1.4	1.3	1.1
Inductive Time Constant	ms	5.1	4.7	5.7	13.5	13.9	15.5	14.6	16.5

* These items and torque-speed characteristics quoted in combination with an SGDB SER-VOPACK at an armature winding temperature of 20°C.

Note These characteristics can be obtained when the following heat sinks (steel plates) are used for cooling purposes:

Type 03A□B to 09A□B : 400×400×20 (mm) (15.75×15.75×0.79 (in))

Type 12A□B to 60A□B : 550×550×30 (mm) (21.65×21.65×1.18 (in))

USING THE DIGITAL OPERATOR

5.2.1 Ratings and Specifications cont.

NOTE The ratings and specifications above refer to a standard servomotor.

Add the numerical values below to the moment of inertia values in the table for a motor fitted with a holding brake.

Other specifications will also change slightly.

Servomotor SGMG			03A□B	06A□B	09A□B	12A□B	20A□B	30A□B	44A□B	60A□B
Holding brake 90VDC	Moment of Inertia Increase	$\times 10^{-4}$ kg·m ²	2.1			8.5			8.5	
		$\times 10^{-3}$ lb·in·s ²	1.86			7.54			7.54	
	Static Friction Torque	N·m	4.41	12.7	43.1			72.6		

上正科技有限公司

購買、維修 此手冊零組件

電話： 037-466333

Email: service@repairtw.com

Line id: @zzzz

www.repairtw.com

Torque-Motor Speed Characteristics

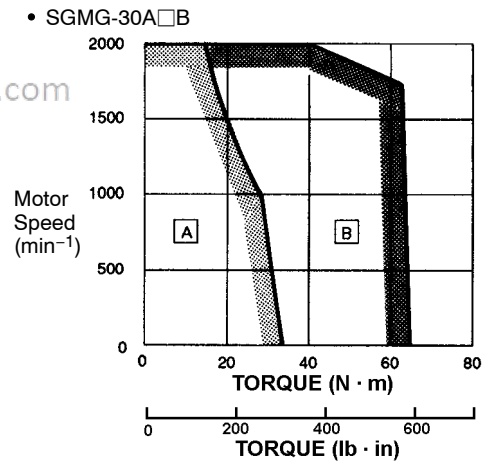
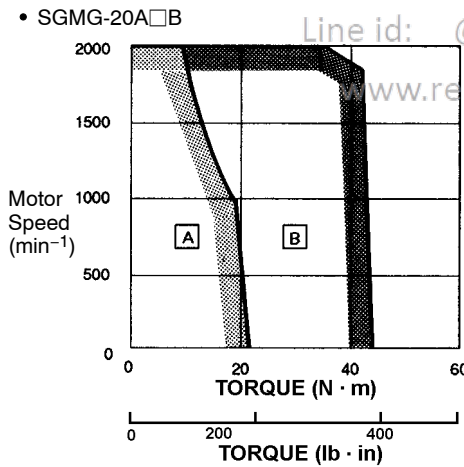
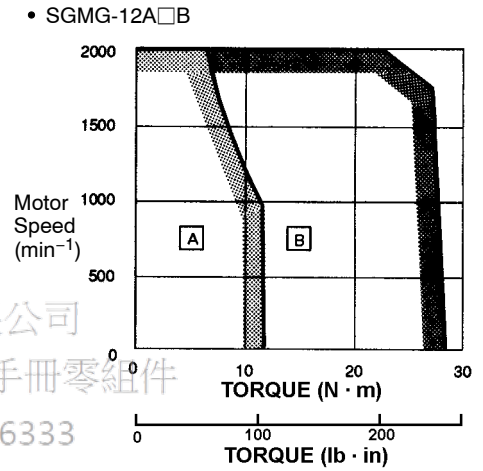
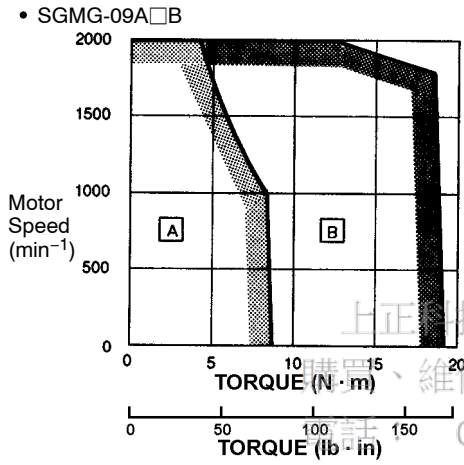
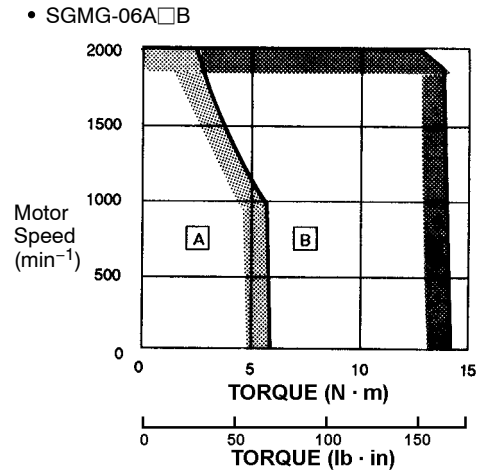
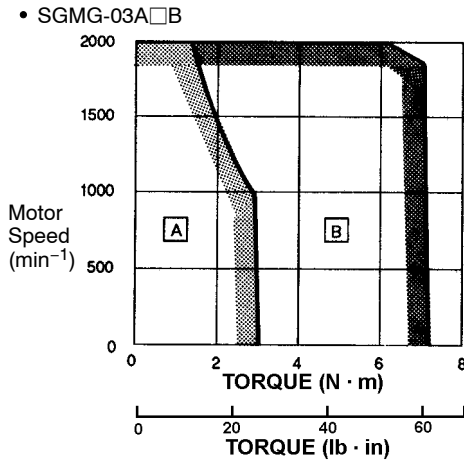

A: Continuous Duty Zone
B: Intermittent Duty Zone

上正科技有限公司
 購買、維修 此手冊零組件
 電話: 037-466333
 Email: service@repairtw.com
 Line id: @zzzz
 www.repairtw.com

5.2.1 Ratings and Specifications cont.

• SGMG-44A□B

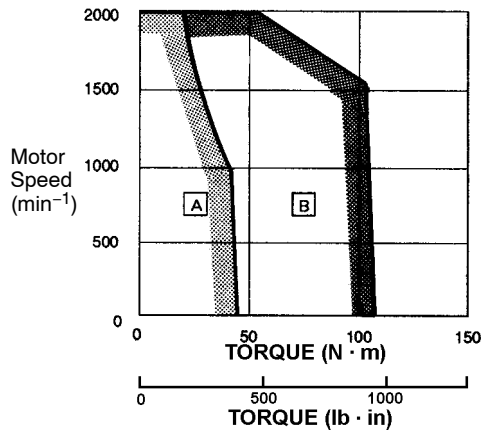

• SGMG-60A□B

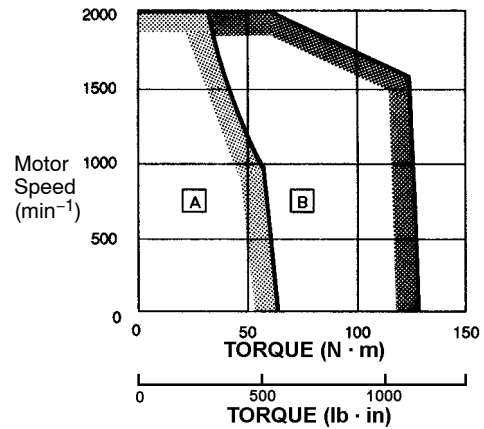

A: Continuous Duty Zone
B: Intermittent Duty Zone

■ SGMG Servomotors with Standard Backlash Gears (Rated Motor Speed is 1000 min⁻¹)

Ratings and Specifications

- Time rating: continuous
- Thermal class: F
- Vibration class: 15µm or below
- Withstand voltage: 1500 VAC for one minute
- Insulation resistance: 500 VDC 10MΩ min.
- Enclosure: totally enclosed, self-cooled IP44 (or the equivalent)
- Ambient temperature: 0 to 40°C
- Ambient humidity: 20% to 80% (non-condensing)
- Excitation: permanent magnet
- Drive method: direct drive
- Mounting: foot and flange mounted
 - Type 4095 to 4115: omni-directional mounting
 - Type 4130 to 4190 horizontal mounting to shaft
- Rotation direction: forward/reverse
- Gear lubricating method: Type 4095 to 4115: grease
Type 4130 to 4190: oil *
- Gear mechanism: planetary gear mechanism
- Backlash: roughly 0.6 to 2° at the gear output shaft

* For oil lubrication, the motor should be mounted horizontal to the shaft. Contact your Yaskawa representative about lubrication for mounting at angles.

Servomotor Model SGMG-	Servomotor			Gear					Load Inertia at the Motor Shaft (Servomotor + Gear) $\times 10^{-4} \text{ kg}\cdot\text{m}^2$ ($\times 10^{-3} \text{ lb}\cdot\text{in}\cdot\text{s}^2$)	Gear Inertia $\times 10^{-4} \text{ Kg}\cdot\text{m}^2$ ($\times 10^{-3} \text{ lb}\cdot\text{in}\cdot\text{s}^2$)
	Output kW	Rated Speed min^{-1}	Rated Torque N·m (lb·in)	Gear Ratio	Rated Torque/Efficiency N·m/% (lb·in/%)	Instantaneous Peak Torque/Efficiency N·m/% (lb·in/%)	Rated Speed min^{-1}	Max. Speed min^{-1}		
-03A□B□AR	0.3	1000	2.84 (25)	1/6	13.6/80 (120/80)	34.4/80 (304/80)	166	333	9.20 (8.14)	1.96 (1.73)
-03A□B□BR				1/11	25.0/80 (221/80)	63.1/80 (558/80)	90	181	8.84 (7.82)	1.6 (1.42)
-03A□B□CR				1/21	41.8/70 (370/70)	106/70 (938/70)	47	95	8.39 (7.43)	1.15 (1.02)
-03A□B□7R				1/29	65.9/80 (583/80)	167/80 (1478/80)	34	68	8.41 (7.44)	1.17 (1.04)
-06A□B□AR	0.6		5.68 (50)	1/6	27.2/80 (241/80)	67.7/80 (599/80)	166	333	15.7 (13.9)	1.8 (1.59)
-06A□B□BR				1/11	50.0/80 (443/80)	125/80 (1106/80)	90	181	15.3 (13.5)	1.4 (1.24)
-06A□B□CR				1/21	83.5/70 (739/70)	208/70 (1841/70)	47	95	15.9 (14.1)	2.0 (1.77)
-06A□B□7R				1/29	123/75 (1089/75)	307/75 (2717/75)	34	68	16.1 (14.3)	2.2 (1.95)
-09A□B□AR	0.9		8.62 (76)	1/6	41.4/80 (366/80)	92.7/80 (820/80)	166	333	22.3 (19.7)	1.8 (1.59)
-09A□B□BR				1/11	75.9/80 (672/80)	170/80 (1505/80)	90	181	21.9 (19.4)	1.4 (1.24)
-09A□B□CR				1/21	136/75 (1204/75)	304/75 (2691/75)	47	95	22.5 (19.9)	2.0 (1.77)
-09A□B□7R				1/29	200/80 (1770/80)	448/80 (3965/80)	34	68	22.8 (20.2)	2.3 (2.04)
-12A□B□AR	1.2		11.5 (102)	1/6	55.0/80 (487/80)	126/75 (1115/75)	166	333	38.0 (33.6)	6.3 (5.58)
-12A□B□BR				1/11	101/80 (894/80)	247/80 (2186/80)	90	181	36.5 (32.3)	4.8 (4.25)
-12A□B□CR				1/21	180/75 (1593/75)	441/75 (3903/75)	47	95	37.6 (33.3)	5.9 (5.22)
-12A□B□7R				1/29	266/80 (2354/80)	651/80 (5762/80)	34	68	37.3 (33.0)	5.6 (4.96)
-20A□B□AR	2.0		19.1 (169)	1/6	91.7/80 (812/80)	212/80 (1876/80)	166	333	52.3 (46.3)	6.3 (5.58)
-20A□B□BR				1/11	169/80 (1496/80)	387/80 (3425/80)	90	181	50.8 (45.0)	4.8 (4.25)
-20A□B□CR				1/21	321/80 (2841/80)	739/80 (6541/80)	47	95	51.9 (45.9)	5.9 (5.22)
-20A□B□7R				1/29	416/75 (3682/75)	958/75 (8479/75)	34	68	91.9 (81.3)	45.9 (40.6)

USING THE DIGITAL OPERATOR

5.2.1 Ratings and Specifications cont.

Servomotor Model SGMG-	Servomotor			Gear					Load Inertia at the Motor Shaft (Servomotor + Gear) $\times 10^{-4} \text{ kg}\cdot\text{m}^2$ ($\times 10^{-3} \text{ lb}\cdot\text{in}\cdot\text{s}^2$)	Gear Inertia $\times 10^{-4} \text{ Kg}\cdot\text{m}^2$ ($\times 10^{-3} \text{ lb}\cdot\text{in}\cdot\text{s}^2$)
	Output kW	Rated Speed min^{-1}	Rated Torque N·m (lb·in)	Gear Ratio	Rated Torque/Efficiency N·m/% (lb·in/%)	Instantaneous Peak Torque/Efficiency N·m/% (lb·in/%)	Rated Speed min^{-1}	Max. Speed min^{-1}		
-30A□B□AR	3.0	1000	28.4 (251)	1/6	136/80 (1204/80)	306/80 (2708/80)	166	333	79.5 (70.4)	12.0 (10.6)
-30A□B□BR				1/11	250/80 (2213/80)	561/80 (4965/80)	90	181	75.2 (66.6)	7.7 (6.82)
-30A□B□CR				1/21	477/80 (4222/80)	1068/80 (9453/80)	47	95	115 (102)	47.5 (42.0)
-30A□B□7R				1/29	660/80 (5842/80)	1480/80 (13099/80)	34	68	131 (116)	63.5 (56.2)
-44A□B□AR	4.4		41.9 (371)	1/6	201/80 (1779/80)	453/70 (4010/70)	166	333	103 (91.2)	14.0 (12.4)
-44A□B□BR				1/11	370/80 (3275/80)	830/70 (7346/70)	90	181	98.8 (87.4)	9.8 (8.67)
-44A□B□CR				1/21	705/80 (6240/80)	1588/70 (14055/70)	47	95	168 (149)	79.0 (69.9)
-44A□B□7R				1/29	973/80 (8612/80)	2185/70 (19339/70)	34	68	166 (147)	77.0 (68.2)
-60A□B□BR	6.0		57.2 (506)	1/11	504/80 (4461/80)	1205/80 (10665/80)	90	181	190 (168)	65.0 (57.5)
-60A□B□CR				1/21	961/80 (8506/80)	2300/80 (20357/80)	47	95	204 (181)	79.0 (69.9)
-60A□B□7R				1/29	1323/80 (11710/80)	3176/80 (28111/80)	34	68	216 (191)	91.0 (80.5)

Note Output torque and motor speed produce the following trends in efficiency. Values in the table are at the rated motor speed.

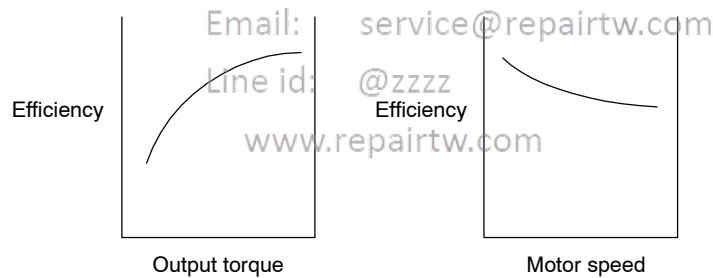

5

Configuration

This configuration accurately and efficiently transmits Servomotor power.

A gear (Cyclo) is used in combination with the internal planetary gear mechanism of the Servomotor.

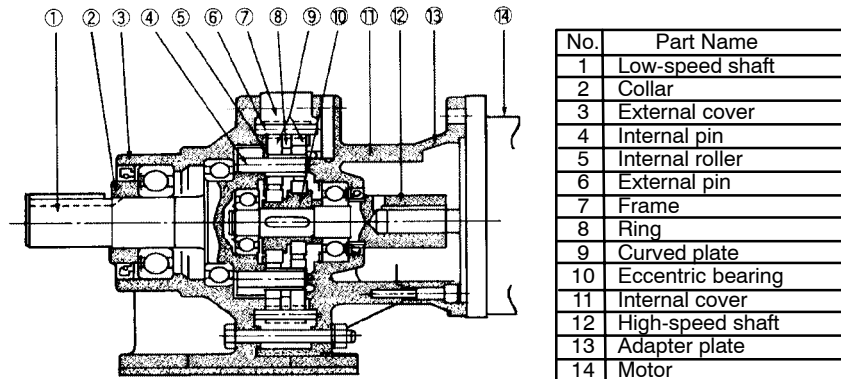

Gear Lubrication

• Grease Lubricating Type (4095 to 4115)

The gearbox is filled at the factory.

• Oil Lubricating Type (4130 to 4190)

All oil is drained from the gears prior to shipment. The gearbox must be filled to the red line at the top of the oil gauge before initial use.

Email: service@repairtw.com

We recommend using industrial extreme-pressure gear oil or SP type or JIS K 2219 industrial gear oil type 2 or equivalent. See the following table.

Ambient Temperature	Manufacturer		
	Kosmo Oil Co., Ltd.	Nihon Sekiyu Co., Ltd.	General Oil Co. Ltd.
0 to 35°C	Kosmo Gear Co., Ltd. SE 100, 150	Bonokku M 100, 150	General SP Gear Roll 100, 150

Approximate amounts of oil applied are shown in the following table.

(Unit: 1 [liters])

Frame No.	4130 4135	4145	4155	4160 4165	4170 4175	4180 4185	4190
Horizontal Type	0.7	0.7	0.7	1.4	1.9	2.5	4.0

■ SGMG Servomotors with Low-backlash Gears (Rated Motor Speed is 1000 min⁻¹)

Ratings and Specifications

Time rating: continuous
 Thermal class: F
 Vibration class: 15µm or below
 Withstand voltage: 1500 VAC for one minute
 Insulation resistance: 500 VDC 10MΩ min.
 Enclosure: totally enclosed, self-cooled
 IP44 (or the equivalent)
 Ambient temperature: 0 to 40°C
 Ambient humidity: 20% to 80% (non-condensing)
 Excitation: permanent magnet
 Drive method: direct drive
 Mounting: flange mounted (can be mounted in any direction)
 Rotation direction: forward
 Gear lubricating method: grease
 Gear mechanism: planetary gear mechanism
 Backlash: 0.05° (3 min) at the gear output shaft

5

Servomotor Model SGMG-	Servomotor			Gear					Gear Inertia × 10 ⁻⁴ kg·m ² (× 10 ⁻³ lb·in·s ²)	Load Inertia at the Motor Shaft (Servomotor + Gear) × 10 ⁻⁴ kg·m ² (× 10 ⁻³ lb·in·s ²)
	Output kW	Rated Speed min ⁻¹	Rated Torque N·m (lb·in)	Gear Ratio	Rated Torque/ Efficiency N·m/% (lb·in/%)	Instantaneous Peak Torque/ Efficiency N·m/% (lb·in/%)	Rated Speed min ⁻¹	Max. Speed min ⁻¹		
-03A□BL1K	0.3	1000	2.84 (25)	1/5	11.4/80 (101/80)	28.7/80 (254/80)	200	400	1.26 (1.12)	8.50 (7.52)
-03A□BL2K				1/9	20.4/80 (181/80)	51.6/80 (457/80)	111	222	0.94 (0.832)	8.18 (7.24)
-03A□BL5K				1/20	45.4/80 (402/80)	115/80 (1018/80)	50	100	1.40 (1.24)	8.64 (7.65)
-03A□BL7K				1/29	65.9/80 (583/80)	166/80 (1469/80)	34	68	2.76 (2.44)	10.0 (8.85)
-03A□BL8K				1/45	102/80 (903/80)	258/80 (2284/80)	22	44	1.81 (1.60)	9.05 (8.01)
-06A□BL1K	0.6		5.68 (50)	1/5	22.7/80 (201/80)	56.4/80 (499/80)	200	400	1.30 (1.15)	15.2 (13.5)
-06A□BL2K				1/9	40.9/80 (362/80)	82.5/80 (730/80)	111	222	0.90 (0.797)	14.8 (13.1)
-06A□BL5K				1/20	90.9/80 (805/80)	226/65 (2000/65)	50	100	4.70 (4.16)	18.6 (16.5)
-06A□BL7K				1/29	132/80 (1168/80)	327/80 (2894/80)	34	68	2.80 (2.48)	16.7 (14.8)
-06A□BL8K				1/45	204/80 (1806/80)	508/80 (4496/80)	22	44	4.50 (3.98)	18.4 (16.3)

Servomotor Model SGMG-	Servomotor			Gear					Gear Inertia $\times 10^{-4}$ kg·m ² ($\times 10^{-3}$ lb·in·s ²)	Load Inertia at the Motor Shaft (Servomotor + Gear) $\times 10^{-4}$ kg·m ² ($\times 10^{-3}$ lb·in·s ²)
	Output kW	Rated Speed min ⁻¹	Rated Torque N·m (lb·in)	Gear Ratio	Rated Torque/Efficiency N·m/% (lb·in/%)	Instantaneous Peak Torque/Efficiency N·m/% (lb·in/%)	Rated Speed min ⁻¹	Max. Speed min ⁻¹		
-09A□BL1K	0.9	1000	8.62 (76)	1/5	34.5/80 (305/80)	77.2/80 (683/80)	200	400	3.40 (3.01)	23.9 (21.2)
-09A□BL2K				1/9	62.1/80 (550/80)	139/80 (1230/80)	111	222	4.80 (4.25)	25.3 (22.4)
-09A□BL5K				1/20	138/80 (1221/80)	309/80 (2735/80)	50	100	6.90 (6.11)	27.4 (24.3)
-09A□BL7K				1/29	200/80 (1770/80)	448/80 (3965/80)	34	68	10.4 (9.21)	30.9 (27.3)
-09A□BL8K				1/45	310/80 (2744/80)	695/80 (6151/80)	22	44	6.70 (5.93)	27.2 (24.1)
-12A□BL1K	1.2		11.5 (102)	1/5	46/80 (407/80)	112/80 (991/80)	200	400	10.2 (9.03)	41.9 (37.1)
-12A□BL2K				1/9	82.8/80 (733/80)	202/80 (1788/80)	111	222	7.80 (6.90)	39.5 (35.0)
-12A□BL5K				1/20	184/80 (1629/80)	448/80 (3965/80)	50	100	20.2 (17.9)	51.9 (45.9)
-12A□BL7K				1/29	267/80 (2363/80)	650/80 (5753/80)	34	68	13.4 (11.9)	45.1 (39.9)
-12A□BL8K				1/45	414/80 (3664/80)	1008/80 (8922/80)	22	44	9.70 (8.59)	41.4 (36.6)
-20A□BL1K	2.0		19.1 (169)	1/5	76.4/80 (676/80)	176/80 (1558/80)	200	400	10.2 (9.03)	56.2 (49.7)
-20A□BL2K				1/9	138/80 (1221/80)	317/80 (2806/80)	111	222	7.80 (6.90)	53.8 (47.6)
-20A□BL5K				1/20	306/80 (2708/80)	704/80 (6231/80)	50	100	20.2 (17.9)	66.2 (58.6)
-30A□BL1K	3.0		28.4 (251)	1/5	114/80 (1009/80)	255/80 (2257/80)	200	400	20.4 (18.1)	87.9 (77.8)
-30A□BL2K				1/9	204/80 (1806/80)	459/80 (4063/80)	111	222	12.5 (11.1)	80.0 (70.8)

Note Output torque and motor speed produce the following trends in efficiency. Values in the table are at the rated motor speed.

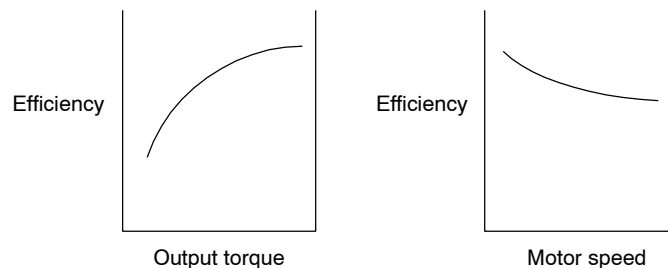

Configuration

This simple planetary gear mechanism is equipped with four planetary gears to which load is evenly distributed via a floating relay ring in each step.

Two gears are used to transmit driving force during forward rotation, and the other two are used to transmit driving force during reverse rotation.

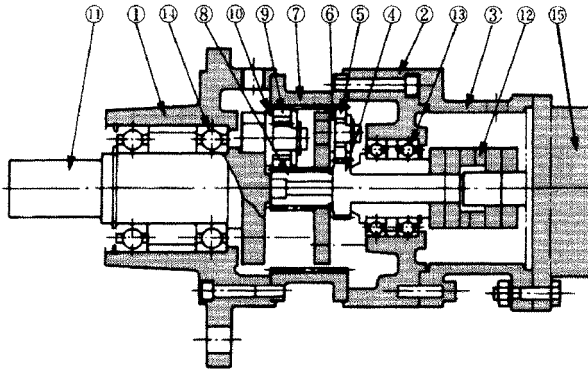

No.	Part Name
1	Casing
2	Bracket
3	Motor bracket
4	Primary sun gear
5	Primary planetary gear
6	Primary planetary shaft
7	Internal gear
8	Secondary sun gear
9	Secondary planetary gear
10	Secondary planetary shaft
11	Low-speed shaft
12	Oldham's coupling
13	High-speed shaft bearing
14	Low-speed shaft bearing
15	Motor

Gear Lubrication

The gearbox is filled at the factory.

上正科技有限公司

購買、維修 此手冊零組件

電話： 037-466333

Email: service@repairtw.com

Line id: @zzzz

www.repairtw.com

■ SGMS Servomotors

Ratings and Specifications

Time rating:	continuous
Thermal class:	F
Vibration class:	15 μ m or below
Withstand voltage:	1500 VAC
Insulation resistance:	500 VDC 10M Ω min.
Enclosure:	totally enclosed, self-cooled IP67 (except for shaft opening)
Ambient temperature:	0 to 40°C
Ambient humidity:	20% to 80% (non-condensing)
Excitation:	permanent magnet
Drive method:	direct drive
Mounting:	flange method

Servomotor SGMS		10A□A	15A□A	20A□A	30A□A	40A□A	50A□A
Rated Output*	kW (HP)	1.0 (1.3)	1.5 (2.0)	2.0 (2.7)	3.0 (4.0)	4.0 (5.4)	5.0 (6.7)
Rated Torque *	N.m	3.18	4.9	6.36	9.8	12.6	15.8
	lb.in	28.2	43	56.4	87	112	140
Instantaneous Peak Torque*	N.m	9.54	14.7	19.1	29.4	37.8	47.6
	lb.in	84.4	130	169	260	336	422
Rated Current*	A (rms)	5.7	9.5	12.4	18.8	24.3	28.2
Instantaneous Max Current*	A (rms)	17	28	42	56	77	84
Rated Speed*	min ⁻¹	3000					
Instantaneous Max Speed*	min ⁻¹	4500					
Torque Constant	N.m/A (rms)	0.636	0.573	0.559	0.573	0.55	0.61
	lb.in/A (rms)	5.6	5.1	5.0	5.1	4.9	5.4
Moment of Inertia	$\times 10^{-4}$ kg.m ²	1.74	2.47	3.19	7.00	9.60	12.3
	$\times 10^{-3}$ lb.in.s ²	1.54	2.19	2.82	6.20	8.50	10.9
Rated Power Rate*	kW/s	57.9	97.2	127	137	166	202
Rated Angular Acceleration*	rad/s ²	18250	19840	19970	14000	13160	12780
Inertia Time Constant	ms	0.87	0.71	0.58	0.74	0.60	0.57
Inductive Time Constant	ms	7.1	7.7	8.3	13.0	14.1	14.7

* These items and torque-speed characteristics quoted in combination with an SGDB SER-VOPACK at an armature winding temperature of 20°C.

Note These characteristics can be obtained when the following heat sinks (aluminum plates) are used for cooling purposes:

Type 10A□A to 20A□A : 300×300×12 (mm) (11.81×11.81×0.47 (in))

Type 30A□A to 50A□A : 400×400×20 (mm) (15.75×15.75×0.79 (in))

USING THE DIGITAL OPERATOR

5.2.1 Ratings and Specifications cont.

NOTE The ratings and specifications above refer to a standard servomotor.

Add the numerical values below to the moment of inertia values in the table for a motor fitted with a holding brake.

Other specifications will also change slightly.

Servomotor SGMS			10A□A	15A□A	20A□A	30A□A	40A□A	50A□A
Holding brake 90VDC	Moment of Inertia Increase	$\times 10^{-4} \text{ kg}\cdot\text{m}^2$	0.325			2.1		
		$\times 10^{-3} \text{ lb}\cdot\text{in}\cdot\text{s}^2$	0.289			1.86		
	Static Friction Torque	N·m	7.84			2.0		

上正科技有限公司

購買、維修 此手冊零組件

電話： 037-466333

Email: service@repairtw.com

Line id: @zzzz

www.repairtw.com

■ SGM Servomotor (Rated Motor Speed is 1000 r/min) Torque-Motor Speed Characteristics

• SGMS-10A□A

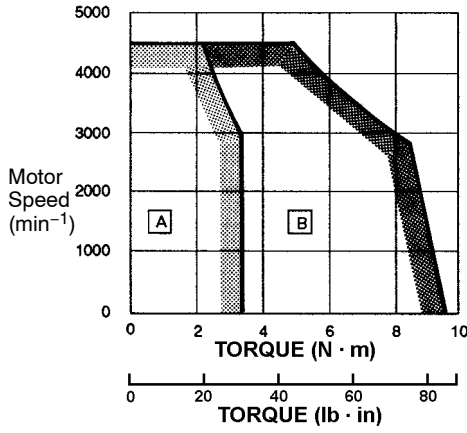

• SGMS-15A□A

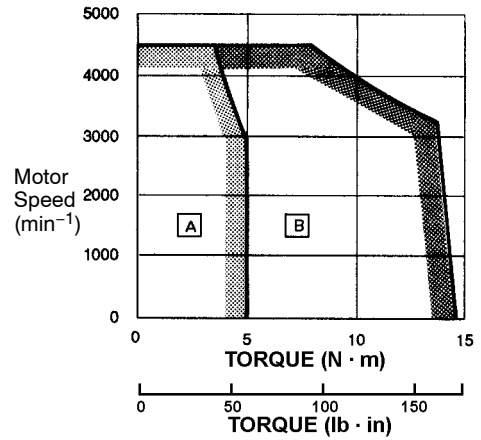

• SGMS-20A□A

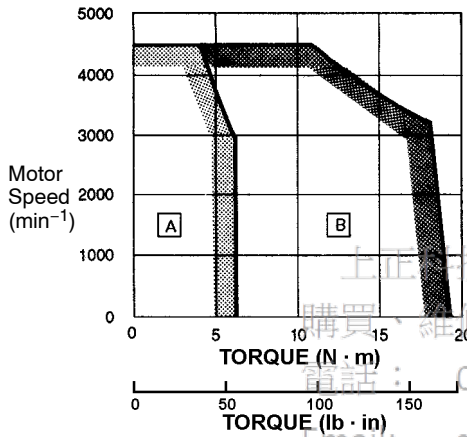

• SGMS-30A□A

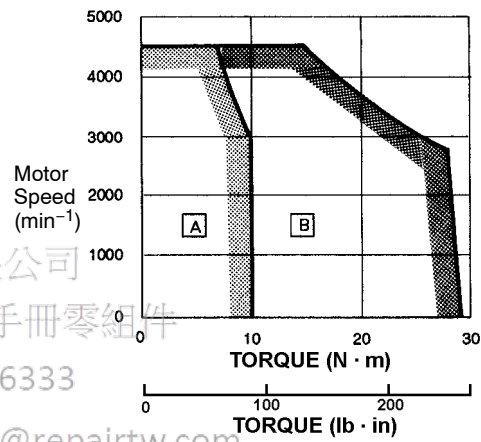

• SGMS-40A□A

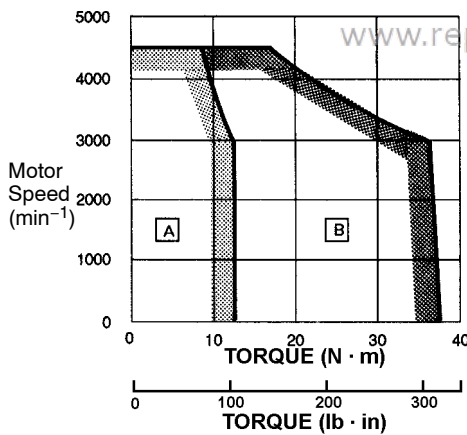

• SGMS-50A□A

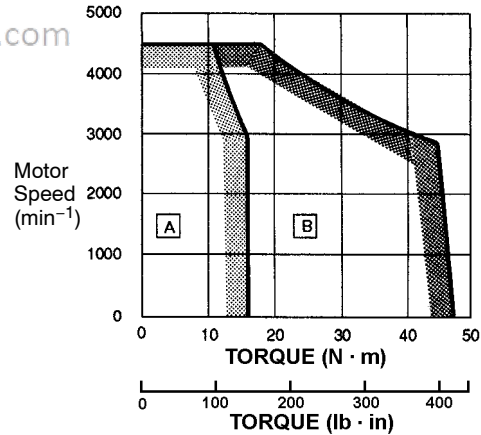

A: Continuous Duty Zone
B: Intermittent Duty Zone

■ SGMS Servomotors with Low-backlash Gears

Ratings and Specifications

Time rating: continuous
 Thermal class: F
 Vibration class: 15 μm or below
 Withstand voltage: 1500 VAC for one minute
 Insulation resistance: 500 VDC 10 MΩ min.
 Enclosure: totally enclosed, self-cooled
 IP44 (or the equivalent)
 Ambient temperature: 0 to 40°C
 Ambient humidity: 20% to 80% (non-condensing)
 Excitation: permanent magnet
 Drive method: direct drive
 Mounting: flange method (can be mounted in any direction)
 Rotation direction: forward
 Gear lubricating method: grease
 Gear mechanism: planetary gear mechanism
 Backlash: 0.05° (3 min) at the gear output shaft

5

Servomotor Model SGMS-	Servomotor			Gear					Gear Inertia × 10 ⁻⁴ kg·m ² (× 10 ⁻³ lb·in·s ²)	Load Inertia at the Motor Shaft (Servomotor + Gear) × 10 ⁻⁴ kg·m ² (× 10 ⁻³ lb·in·s ²)
	Output kW	Rated Speed min ⁻¹	Rated Torque N·m (lb·in)	Gear Ratio	Rated Torque/ Efficiency N·m/% (lb·in/%)	Instantaneous Peak Torque/ Efficiency N·m/% (lb·in/%)	Rated Speed min ⁻¹	Max. Speed min ⁻¹		
-10A□AL1K	1.0	3000	3.18 (28.2)	1/5	12.7/80 (112/80)	38.2/80 (338/80)	600	800	3.44 (3.04)	5.18 (4.58)
-10A□AL2K				1/9	22.9/80 (203/80)	68.7/80 (608/80)	333	444	3.11 (2.75)	4.85 (4.29)
-10A□AL5K				1/20	50.9/80 (451/80)	153/80 (1354/80)	150	200	6.79 (6.01)	8.53 (7.55)
-10A□AL7K				1/29	73.8/80 (653/80)	221/80 (1956/80)	103	138	4.88 (4.32)	6.62 (5.86)
-10A□AL8K				1/45	115/80 (1018/80)	343/80 (3036/80)	66	89	3.92 (3.47)	5.66 (5.01)
-15A□AL1K	1.5	3000	4.9 (43)	1/5	19.6/80 (173/80)	58.8/80 (520/80)	600	800	3.44 (3.04)	5.91 (5.23)
-15A□AL2K				1/9	35.3/80 (312/80)	106/80 (938/80)	333	444	4.77 (4.22)	7.24 (6.41)
-15A□AL5K				1/20	78.4/80 (694/80)	235/80 (2080/80)	150	200	6.79 (6.01)	9.26 (8.20)
-15A□AL7K				1/29	114/80 (1009/80)	341/80 (3018/80)	103	138	4.88 (4.32)	7.35 (6.51)
-15A□AL8K				1/45	176/80 (1558/80)	529/80 (4682/80)	66	89	6.58 (5.82)	9.05 (8.01)

Servomotor Model SGMS-	Servomotor			Gear					Gear Inertia $\times 10^{-4}$ kg·m ² ($\times 10^{-3}$ lb·in·s ²)	Load Inertia at the Motor Shaft (Servomotor + Gear) $\times 10^{-4}$ kg·m ² ($\times 10^{-3}$ lb·in·s ²)
	Output kW	Rated Speed min ⁻¹	Rated Torque N·m (lb·in)	Gear Ratio	Rated Torque/ Efficiency N·m/% (lb·in/%)	Instantaneous Peak Torque/ Efficiency N·m/% (lb·in/%)	Rated Speed min ⁻¹	Max. Speed min ⁻¹		
-20A□AL1K	2.0	3000	6.36 (56.4)	1/5	25.6/80 (227/80)	76.4/80 (676/80)	600	800	3.44 (3.04)	6.63 (5.87)
-20A□AL2K				1/9	46/80 (407/80)	138/80 (1221/80)	333	444	4.77 (4.22)	7.96 (7.05)
-20A□AL5K				1/20	102/80 (903/80)	306/80 (2708/80)	150	200	6.79 (6.01)	9.98 (8.83)
-20A□AL7K				1/29	148/80 (1310/80)	443/80 (3921/80)	103	138	10.3 (9.12)	13.5 (11.9)
-20A□AL8K				1/45	230/80 (2036/80)	688/80 (6089/80)	66	89	6.58 (5.82)	9.77 (8.65)
-30A□AL1K	3.0		9.8 (87)	1/5	39.2/80 (347/80)	118/80 (1044/80)	600	800	10.2 (9.03)	17.2 (15.2)
-30A□AL2K				1/9	70.5/80 (624/80)	212/80 (1876/80)	333	444	7.80 (6.90)	14.8 (13.1)
-30A□AL5K				1/20	157/80 (1390/80)	470/80 (4160/80)	150	200	20.2 (17.9)	27.2 (24.1)
-30A□AL7K				1/29	227/80 (2009/80)	682/80 (6036/80)	103	138	13.4 (11.9)	20.4 (18.1)
-30A□AL8K				1/45	353/80 (3124/80)	1058/80 (9364/80)	66	89	9.70 (8.59)	16.7 (14.8)
-40A□AL1K	4.0		12.6 (112)	1/5	50.4/80 (446/80)	151/80 (1337/80)	600	800	10.2 (9.03)	19.8 (17.5)
-40A□AL2K				1/9	90.7/80 (803/80)	272/80 (2407/80)	333	444	12.5 (11.1)	22.1 (19.6)
-40A□AL5K				1/20	202/80 (1788/80)	605/80 (5355/80)	150	200	20.2 (17.9)	29.8 (26.4)
-40A□AL7K				1/29	292/80 (2584/80)	877/80 (7762/80)	103	138	13.4 (11.9)	23.0 (20.4)
-50A□AL1K	5.0		15.8 (140)	1/5	63.2/80 (559/80)	190/80 (1682/80)	600	800	20.4 (18.1)	32.7 (28.9)
-50A□AL2K				1/9	114/80 (1009/80)	343/80 (3036/80)	333	444	12.5 (11.1)	24.8 (22.0)
-50A□AL5K				1/20	253/80 (2239/80)	762/80 (6744/80)	150	200	20.2 (17.9)	32.5 (28.8)

- Note 1.** The maximum input motor speed for the gear is 4000 min⁻¹.
- 2.** Output torque and motor speed produce the following trends in efficiency. Values in the table are at the rated motor speed.

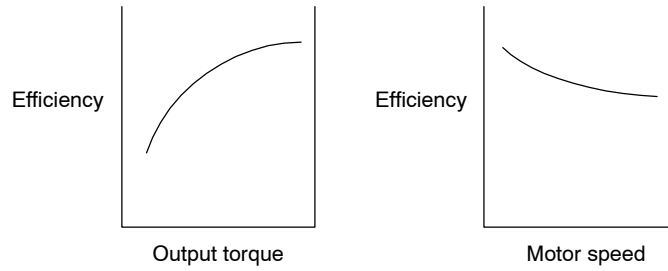

Configuration

This simple planetary gear mechanism is equipped with four planetary gears to which load is evenly distributed via a floating relay ring in each step.

Two gears are used to transmit driving force during forward rotation, and the other two are used to transmit driving force during reverse rotation.

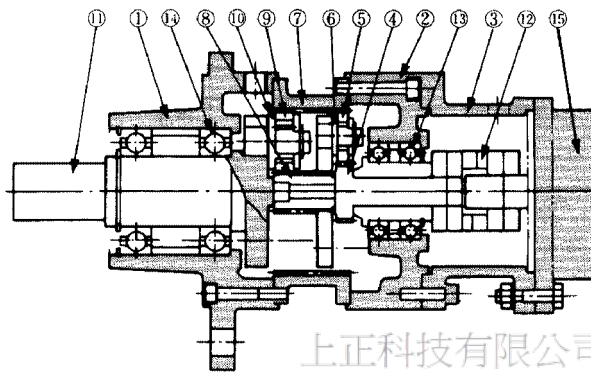

No.	Part Name
1	Casing
2	Bracket
3	Motor bracket
4	Primary sun gear
5	Primary planetary gear
6	Primary planetary shaft
7	Internal gear
8	Secondary sun gear
9	Secondary planetary gear
10	Secondary planetary shaft
11	Low-speed shaft
12	Oldham's coupling
13	High-speed shaft bearing
14	Low-speed shaft bearing
15	Motor

5

上正科技有限公司

購買、維修 此手冊零組件

Gear Lubrication

The gearbox is filled at the factory.

電話： 037-466333

Email: service@repairtw.com

Line id: @zzzz

www.repairtw.com

■ SGMD Servomotors with Holding Brake

Ratings and Specifications

Time rating:	continuous
Thermal class:	F
Vibration class:	15 μ m or below
Withstand voltage:	1500 VAC
Insulation resistance:	500 VDC 10M Ω min.
Enclosure:	totally enclosed, self-cooled IP67 (except for shaft opening)
Ambient temperature:	0 to 40°C
Ambient humidity:	20% to 80% (non-condensing)
Excitation:	permanent magnet
Drive method:	direct drive
Mounting:	flange method
Holding brake:	90VDC Static friction torque 29.4 N·m

Servomotor SGMD		22A□AAB	32A□AAB	40A□AAB
Rated Output*	kW (HP)	2.2 (2.9)	3.2 (4.3)	4.0 (5.4)
Rated Torque *	N·m	10.5	15.3	19.1
	kgf·cm (lb·in)	107 (93)	156 (135)	195 (169)
Instantaneous Peak Torque*	N·m	36.7	53.5	66.9
	kgf·cm (lb·in)	375 (326)	546 (474)	682 (592)
Rated Current *	A (rms)	15.7	20.9	22.8
Instantaneous Max Current*	A (rms)	54	73	77
Rated Speed*	min ⁻¹	2000		
Instantaneous Max Speed*	min ⁻¹	3000		
Torque Constant	N·m/A (rms)	0.72	0.78	0.93
	kgf·cm/A (lb·in/A) (rms)	7.4 (6.4)	8.0 (6.9)	9.5 (8.2)
Moment of Inertia	kg·m ² × 10 ⁻⁴	56.6	74.2	91.8
	gf·cm·s ² (lb·in·s ² × 10 ⁻³)	57.8 (50.3)	75.7 (65.9)	93.7 (81.5)
Rated Power Rate*	kW/s	21.6	34.1	42.3
Rated Angular Acceleration*	rad/s ²	2060	2230	2220
Inertia Time Constant	ms	3.3	2.2	2.0
Inductive Time Constant	ms	16.2	18.2	17.8

* These items and torque-speed characteristics quoted in combination with an SGDB SER-VOPACK at an armature winding temperature of 20°C.

Note These characteristics can be obtained when the following heat sinks (steel plates) are used for cooling purposes:

Type 22A□AAB to 40A□AAB :650×650×35 (mm)
(25.59×25.59×1.38 (in))

Torque-Motor Speed Characteristics

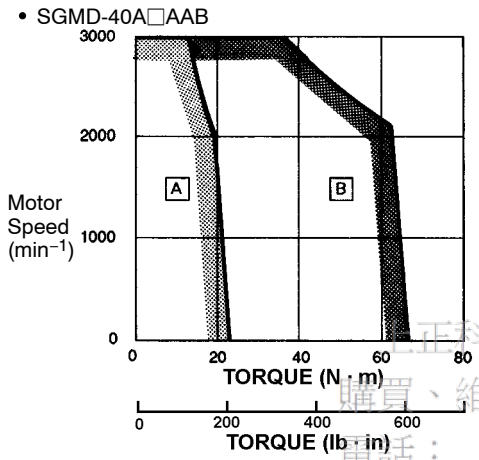
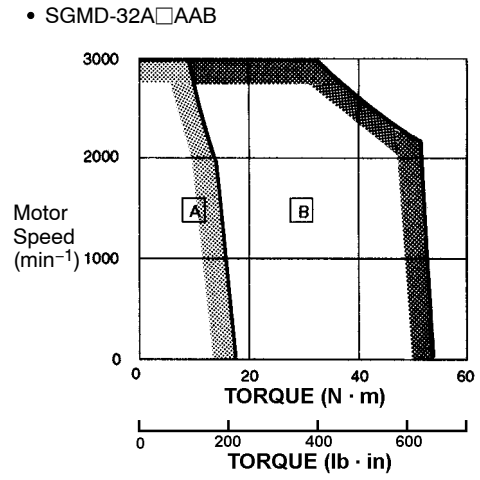
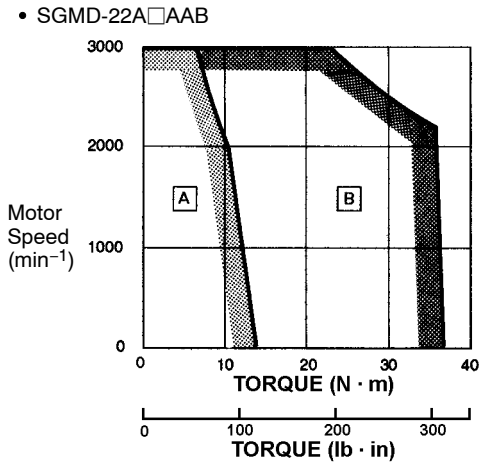

5

正科技有限公司
 購買、維修 此手冊零組件

電話： 037-466333

Email: service@repairtw.com

A: Continuous Duty Zone @zzzz

B: Intermittent Duty Zone

www.repairtw.com

■ SGMP Servomotors (1.5kW)

Ratings and Specifications

Time rating:	continuous
Thermal class:	B
Vibration class:	15 μ m or below
Withstand voltage:	1500 VAC
Insulation resistance:	500 VDC 10M Ω min.
Enclosure:	totally enclosed, self-cooled IP67 (except for shaft opening)
Ambient temperature:	0 to 40°C
Ambient humidity:	20% to 80% (non-condensing)
Excitation:	permanent magnet
Drive method:	direct drive
Mounting:	flange method

Servomotor SGMP		04A	08A	15A
Rated Output* ¹	kW (HP)	0.4 (0.54)	0.75 (1.01)	1.5 (2.0)
Rated Torque * ¹ * ²	N·m	1.27	2.39	4.77
	lb·in	11.2	21.1	42.2
Instantaneous Peak Torque* ¹	N·m	3.82	7.1	14.3
	lb·in	33.8	62.8	126.6
Rated Current* ¹	A (rms)	2.6	4.1	7.5
Instantaneous Max Current* ¹	A (rms)	8.0	13.9	23.0
Rated Speed* ¹	min ⁻¹	3000		
Instantaneous Max Speed* ¹	min ⁻¹	4500		
Torque Constant	N·m/A (rms)	0.535	0.641	0.687
	lb·in/A (rms)	4.73	5.67	6.08
Moment of Inertia	$\times 10^{-4}$ kg·m ²	0.347	2.11	4.03
	$\times 10^{-3}$ oz·in·s ²	4.92	29.9	3.57
Rated Power Rate* ¹	kW/s	46.8	26.9	56.6
Rated Angular Acceleration* ¹	rad/s ²	36700	11300	11800
Inertia Time Constant	ms	0.4	0.7	0.5
Inductive Time Constant	ms	8.5	18	22

*¹ These items and torque-motor speed characteristics quoted in combination with an SGDB SERVOPACK at an armature winding temperature of 100°C. Other values quoted at 20°C. All values typical.

*² Rated torques are continuous allowable torque values at 40°C with a 300 \times 300 \times 12 (mm) (11.81 \times 11.81 \times 0.47 (in)) heat sink attached.

NOTE The ratings and specifications above refer to a standard servomotor.

Add the numerical values below to the moment of inertia values in the table for a motor fitted with a holding brake.

Other specifications will also change slightly.

Item		Type SGMP-	04A	08A	15A
		Holding brake 90VDC	Moment of Inertia Increase	$\times 10^{-4} \text{ kg}\cdot\text{m}^2$	0.109
$\times 10^{-3} \text{ lb}\cdot\text{in}\cdot\text{s}^2$	0.0965			0.774	0.774
Static Friction Torque	N·m		1.91	3.58	7.15

■ SGMP servomotor (1.5kW) Torque-Motor Speed Characteristics

• SGMP-15A

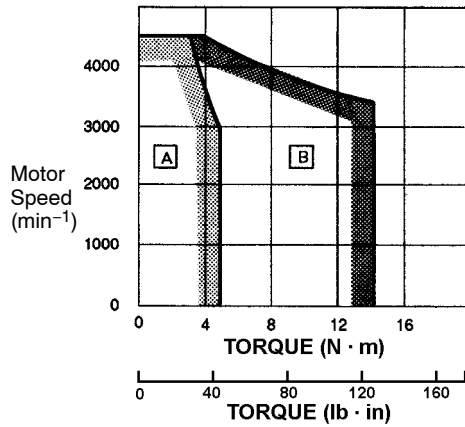

• SGMP-04A

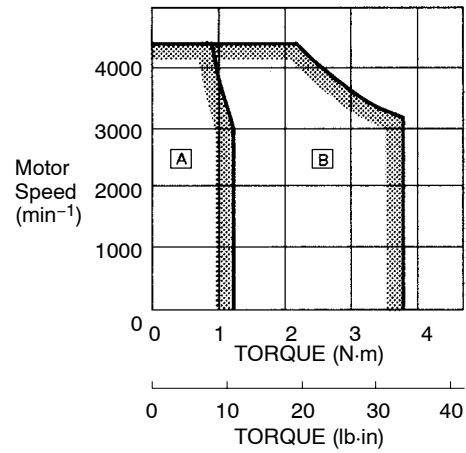

• SGMP-08A

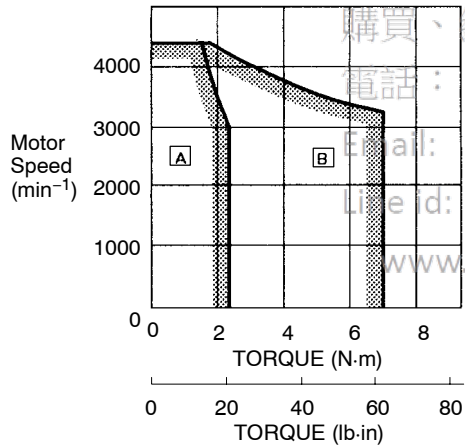

上正科技有限公司

購買、維修 此手冊零組件

電話： 037-466333

Email: service@repairtw.com

Line id: @zzzz

www.repairtw.com

A: Continuous Duty Zone
B: Intermittent Duty Zone

5.2.2 Mechanical Characteristics

■ Allowable Radial Load, Allowable Thrust Load

The output shaft allowable loads for SGM \square servomotor are shown below.

Conduct mechanical design such that the thrust loads and radial loads do not exceed the values stated below.

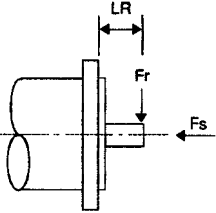
Servomotor Type	Allowable Radial Load Fr [N(lb)]	Allowable Thrust Load Fs [N(lb)]	LR mm (in.)	Reference Diagram
SGMG-05A \square A	490 (110)	98 (22)	58	
-09A \square A	490 (110)	98 (22)	(2.28)	
-13A \square A	686 (154)	343 (77)		
-20A \square A	1176 (265)	490 (110)	79	
-30A \square A	1470 (331)	490 (110)	(3.11)	
-44A \square A	1470 (331)	490 (110)		
-55A \square A	1764 (397)	588 (132)	113	
-75A \square A	1764 (397)	588 (132)	(4.45)	
-1AA \square A	1764 (397)	588 (132)	116	
-1EA \square A	4998 (1125)	2156 (485)	(4.57)	
SGMG-03A \square B	490 (110)	98 (22)	58	
-06A \square B	490 (110)	98 (22)	(2.28)	
-09A \square B	686 (154)	343 (77)		
-12A \square B	1176 (265)	490 (110)	79	
-20A \square B	1470 (331)	490 (110)	(3.11)	
-30A \square B	1470 (331)	490 (110)		
-44A \square B	1764 (397)	588 (132)	113	
-60A \square B	1764 (397)	588 (132)	(4.45)	
SGMS-10A	686 (154)	196 (44)	45	
-15A	686 (154)	196 (44)	(1.77)	
-20A	686 (154)	196 (44)		
-30A	980 (221)	392 (88)	63	
-44A	1176 (265)	392 (88)	(2.48)	
-50A	1176 (265)	392 (88)		
SGMD-22A	1176 (265)	490 (110)	55	
-32A	1176 (265)	490 (110)	(2.17)	
-40A	1176 (265)	490 (110)	65	
			(2.56)	
SGMP-15A	490 (110)	147 (33)	35	
			(1.38)	

Note Allowable radial loads shown above are the maximum values that could be applied to the shaft end.

■ Mechanical Tolerance

The tolerances of the SGM□ servomotor output shaft and installation are shown in the table below.

Tolerance (T.I.R.)		Reference Diagram
Perpendicularity between flange face and output shaft (A)	0.04mm (0.0016in.)	
Mating concentricity of flange O.D. (B)	0.04mm (0.0016in.)	
Run-out at end of shaft (C)	0.02mm* (0.00079in.)	

* 0.02 mm (0.00079 in.) or more for the following servomotors.
 SGMG-55A□A or above
 SGMG-44A□B or above

Note T.I.R. = Total Indicator Reading

■ Direction of Motor Rotation

Positive rotation of the servomotor is counter-clockwise, viewing from the drive end.

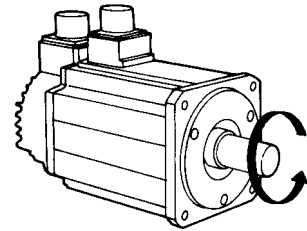

■ Impact Resistance

Mount the servomotor with the axis horizontal. The servomotor must withstand the following vertical impacts.

- Impact Acceleration: 490 m/s²
 - Number of Impacts: 2
- (SGMP-15A)
- Impact Acceleration: 98 m/s²
 - Number of Impacts: 2

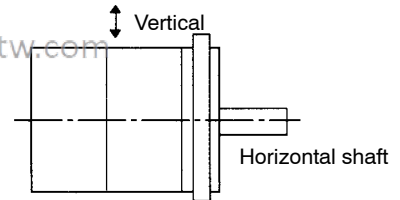

NOTE In SGM□ servomotors, an accurate detector is attached to the shaft at the opposite end from the load. Avoid applying impacts directly to the shaft as these may damage the detector.

上正科技有限公司
 購買、維修 此手冊零組件
 電話: 093-4063333
 Email: service@repairtw.com
 Line id: @zzzz
 www.repairtw.com

■ Vibration Resistance

Mount the servomotor with the axis horizontal. The servomotor must withstand the following vibration accelerations in three directions: vertical, transverse, and longitudinal. The amount of vibration the servomotor endures will vary depending on the application. Check the vibration acceleration being applied to your servomotor for each application.

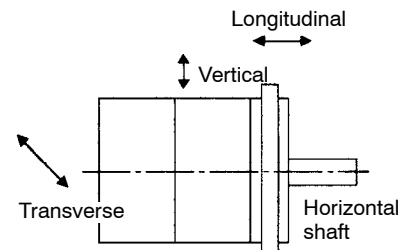

- Vibration Acceleration: 24.5 m/s²

■ Vibration Class

The SGM□ servomotor meets the following **vibration class** at rated speed.

- Vibration Class: 15μm or below

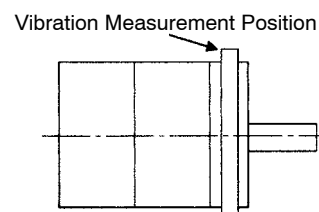

上正科技有限公司

購買、維修 此手冊零組件

電話： 037-466333

Email: service@repairtw.com

Line id: @zzzz

www.repairtw.com



Vibration Class

Vibration class 15μm or below indicates that the total amplitude of vibration of the motor alone, running at rated speed, does not exceed 15μm.

5.2.3 Option Specifications

Option specifications for SGMG, SGMS, and SGMD servomotors are described below.

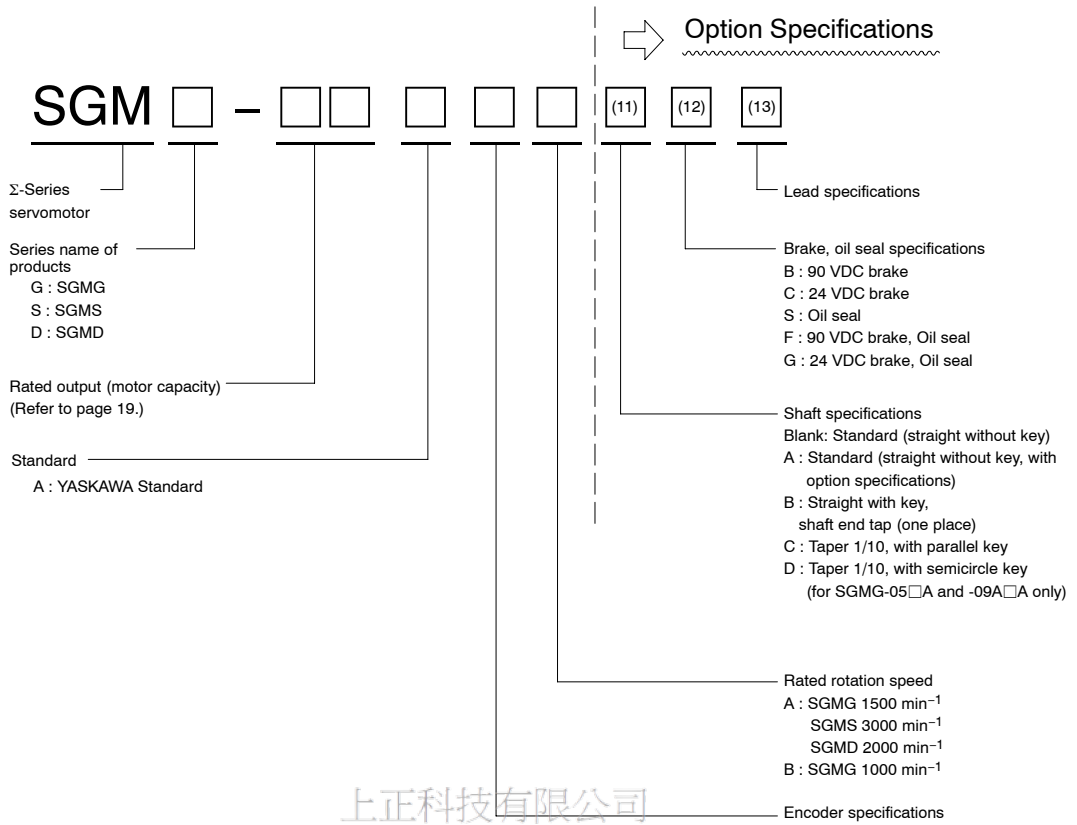

5

Encoder	Incremental Encoder				Absolute Encoder			
	Motor Series	Standard	Option	Standard	Option			
G	2	8192P/R	6	4096P/R	S	8192P/R (15 bit)		
S	6	4096P/R	2	8192P/R*	-	W	1024P/R (12 bit)	
D	-	-	2	8192P/R	W	1024P/R (12 bit)	S	8192P/R (15 bit)
			6	4096P/R				

* Allowable rotation speed : 3000 min⁻¹

■ Shaft Specifications for SGMG, SGMS, and SGMD Servomotors

SGM□ – □□□□□□□□□□

Shaft specifications

Blank : Standard (straight without key)

(Apply when option specifications for brake, oil seal, and lead not provided.)

A : Standard (straight without key)

B : Straight with key, shaft end tap (one place)

(Keyway confirming to JISB1301-1976.)

C : Taper 1/10, with parallel key

(Keyway confirming to JISB1301-1976. SGMG series will be interchangeable with USAGED series.)

D : Taper 1/10, with semicircle key (non-standard)

(For SGMG-05 and -09 only. Semicircle key confirming to JISB1302.)

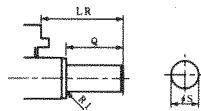

A : Straight without Key

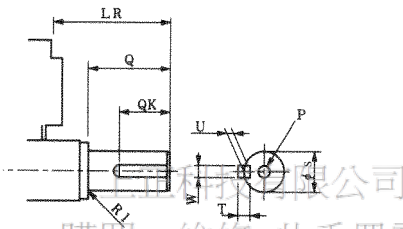

B : Straight with Key and Shaft End Tap

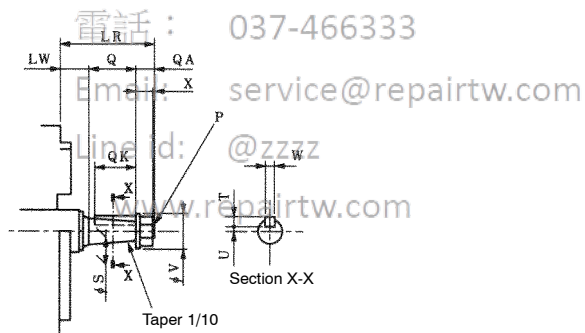

C : Taper 1/10, with Parallel Key

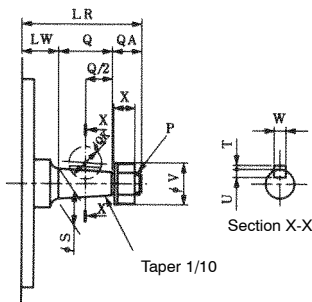

D : Taper 1/10, with Semicircle Key

USING THE DIGITAL OPERATOR

5.2.3 Option Specifications cont.

Co- de	Specifi- cation		Type																			
			SGMS-					SGMG-										SGMD-				
			10	15	20	30	40	50	03B	06B	09B	12B	20B	30B	44B	60B	-	1EA	22	32	40	
						05A	09A	13A	20A	30A	44A	55A	75A	1AA								
A	Straight	LR	45		63		58			79			113			116	116	116	55	65		
		Q	40		55		40			76			110			110	110	110	50	60		
		S	24 ^{-0.013}		28 ^{-0.013}		19 ^{-0.013}		22 ^{-0.013}		35 ^{+0.01} ₀		42 ^{-0.016}		42 ^{-0.016}		55 ^{+0.030} _{+0.011}		28 ^{-0.013}		32 ^{-0.016}	
B	Straight with key and shaft end tap	LR	45		63		58			79			113			116	116	116	55	65		
		Q	40		55		40			76			110			110	110	110	50	60		
		QK	32		50		25			60			90			90	90	90	45	50		
		S	24 ^{-0.013}		28 ^{-0.013}		19 ^{-0.013}		22 ^{-0.013}		35 ^{+0.01} ₀		42 ^{-0.016}		42 ^{-0.016}		55 ^{+0.030} _{+0.011}		28 ^{-0.013}		32 ^{-0.016}	
		W	8				5		6		10		12		12		16	8	10			
		T	7				5		6		8						10	7	8			
		U	4				3		3.5		5						6	4	5			
C	Taper 1/10, with par- allel key	LR	70		80		58			102			132			132	-	-				
		LW	20				18			22						-	-					
		Q	36		42		28			58			82			82	-	-				
		QA	14		18		12			22			28			28	-	-				
		QK	32		36		25*1			50			70			70	-	-				
		X	12.5		16		10.3			19.2			23			26	-	-				
		S	24		28		16		19		32		42		55		-	-				
		V	24		30		21		37		44		60		-	-						
		P	M12, P1.25		M16, P1.5		M10, P1.25		M20, P1.5		M24, P2.0		M36, P3.0		-	-						
		W	8				5		7		10		14		-	-						
		T	7				5*2		7		8		9		-	-						
		U	7.1		8.95		4.3*3		5.8		10.55		13.95		19.95		-	-				
D	Taper 1/10, with semi- circle key	LR					58															
		LW					18															
		Q					28															
		QA					12															
		QK					16															
		X					10.3															
		S	-		-				-		-		-		-							
		V					21															
		P					M10, P1.25															
		W					5															
		T					2															
U					4.5																	

*1 The value will be 16 if SGMG-05A and 09A are not interchangeable.
 *2 The value will be 2 if SGMG-05A and 09A are not interchangeable.
 *3 The value will be 4.5 if SGMG-05A and 09A are not interchangeable.

5

■ Brake, Oil Seal Specification

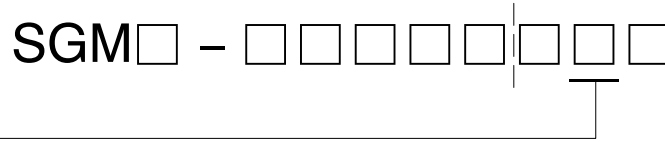

⊙ Standard ○ Non-standard

Code	Specifications	SGMS	SGMG	SGMD										
Blank	Option not provided (standard) (Apply when optional lead specifications not provided.)	⊙	⊙	○										
1	Option not provided (standard)	⊙	⊙	○										
S	With oil seal	○	○	○										
	<table border="1"> <thead> <tr> <th>Flange Angle</th> <th>Type</th> <th>Material</th> </tr> </thead> <tbody> <tr> <td><input type="checkbox"/>100</td> <td rowspan="2">SC30458</td> <td rowspan="4">Nitrile</td> </tr> <tr> <td><input type="checkbox"/>130</td> </tr> <tr> <td><input type="checkbox"/>180</td> <td rowspan="2">SC45629 (15kW : SC658510)</td> </tr> <tr> <td><input type="checkbox"/>220</td> </tr> </tbody> </table>				Flange Angle	Type	Material	<input type="checkbox"/> 100	SC30458	Nitrile	<input type="checkbox"/> 130	<input type="checkbox"/> 180	SC45629 (15kW : SC658510)	<input type="checkbox"/> 220
	Flange Angle				Type	Material								
	<input type="checkbox"/> 100				SC30458	Nitrile								
	<input type="checkbox"/> 130													
<input type="checkbox"/> 180	SC45629 (15kW : SC658510)													
<input type="checkbox"/> 220														
Enclosure : IP67 (including shaft opening)														
B	90 VDC brake	○	○	⊙										
C	24 VDC brake	○	○	○										
F	90 VDC brake, oil seal	○	○	○										
G	24 VDC brake, oil seal	○	○	○										

5

上正科技有限公司
 購買、維修 此手冊零組件
 電話： 037-466333
 Email: service@repairtw.com
 Line id: @zzzz
 www.repairtw.com

■ Lead Specifications

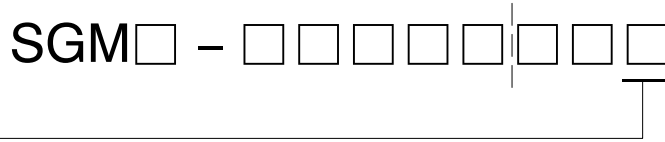

⊙ Standard ○ Non-standard

Code	Specifications	Outgoing-lead Opening *1	SGMS	SGMG	SGMD
Blank	MS connector : Receptacle MS3102A (Standard)		⊙	⊙	⊙
B	<p>(Receptacle size is same as standard type.)</p>	(a)	○	○ *2	○
C		(b)			
D	With loose wire (500 mm), and MS connector at the lead end (with MS3101A plug)	(a)	○	-	-
E	For SGMS-10, -15 and -20 Enclosure : IP44	(b)			
F	With loose wire (500 mm), insertion-type pin terminal at the motor end, and connector at the encoder end	(a)	○	-	-
G	For SGMS-10, -15 and -20 Enclosure : IP44	(b)			

5

上正科技有限公司
 購買、維修 此手冊零組件
 電話：097-466330
 Email: service@repairtw.com
 Line id: @zzzz

*1 Outgoing-lead openings

www.repairtw.com

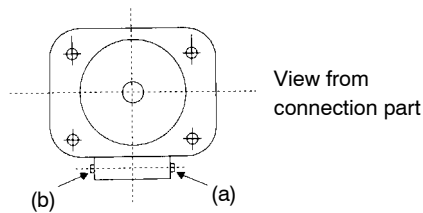

*2 Depends on motor capacity. Contact your YASKAWA representative.

■ 90 ° Bending Support Specifications

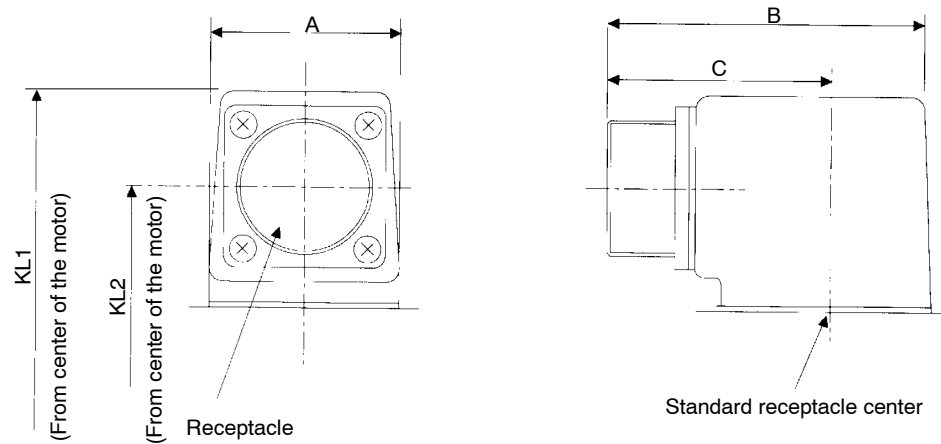

in mm

			SGMS-						SGMG-										SGMD-		
									03 B	06 B	09 B	12 B	20 B	30 B	44 B	60 B					
			10	15	20	30	40	50	05 A	09 A	13 A	20 A	30 A	44 A	55 A	75 A	1A A	1E A	22	32	40
Servo motor Side	With out brake	Receptacle	MS3102A 18-10P			MS3102A 22-22P			MS3102A 18-10P			MS3102A 22-22P				MS3102A 32-17P		MS3102A 24-10P			
		A	42			48			42			48				63		48			
		B	79			86			79			86				113		88			
		C	58			62			58			62				81		64			
		KL1	99			118			113			143				164		183		162	
	KL2	77			95			91			120				131		150		139		
	With brake	Receptacle	MS3102A 20-15P			MS3102A 24-10P			MS3102A 20-15P			MS3102A 24-10P				MS3102A 32-17P		MS3102A 24-10P			
		A	42			48			42			48				63		48			
		B	79			88			79			88				113		88			
		C	58			64			58			64				81		64			
KL1		99			118			113			143				164		183		162		
KL2	77			95			91			120				131		150		139			
Encoder side	Receptacle	MS3102A20-29P																			
	A	42																			
	B	79																			
	C	58																			
	KL1	112																			
	KL2	90																			

5

■ Specifications of Lead with MS Connectors

• Servomotor end

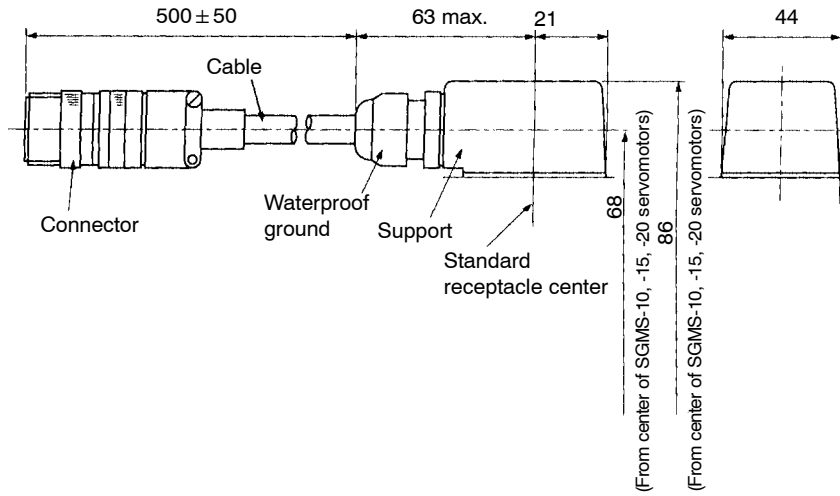

• Encoder end

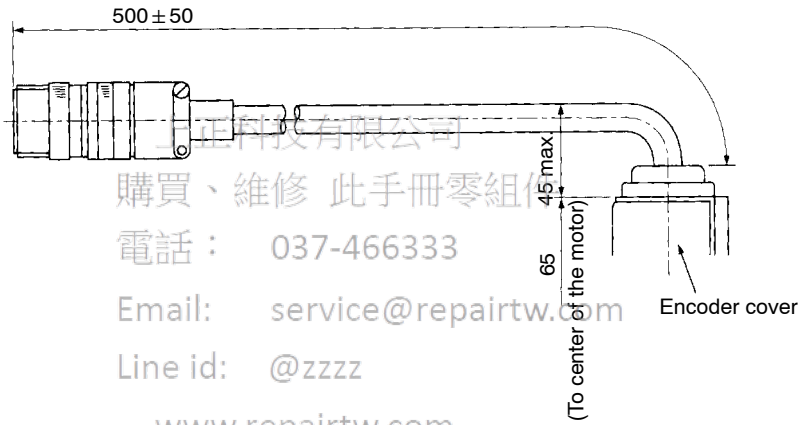

5

	SGMS-10, -15, -20	
	Brake	Connector Type
Servomotor End	Without	MS3101A18-10P
	With	MS3101A20-15P
Encoder End	-	MS3101A20-29P

■ Specifications of Lead with Connectors

• Servomotor end

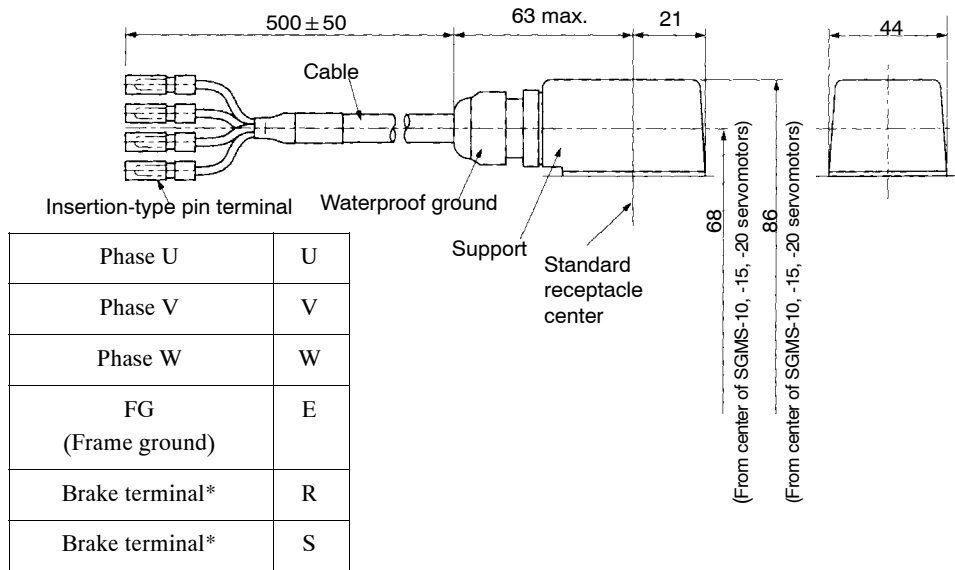

* For servomotors with brake only

• Encoder end

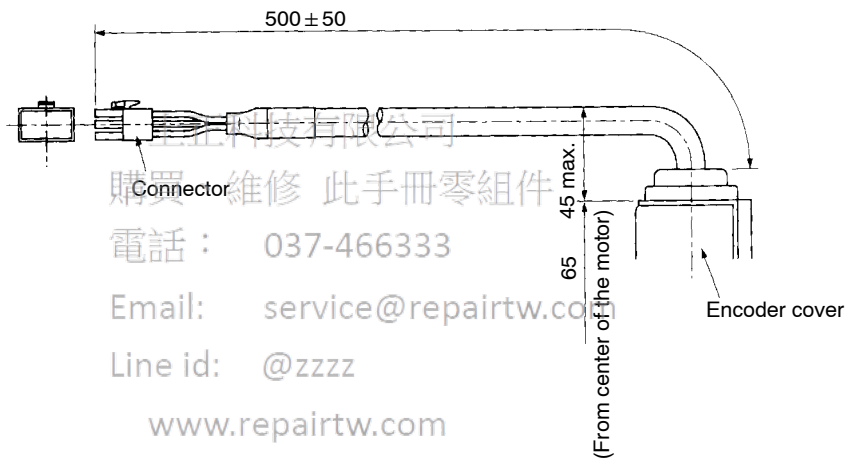

5

		SGMS-10, -15, -20	
		Specifications	Connector Type
Servomotor End	With brake		PC-4020M (4 connectors) Made by NICHIFU
	Without brake	Motor section : PC-4020M (4 connectors) Brake section : PC-2005M (2 connectors)	Made by NICHIFU
Encoder End	With incremental encoder	Plug : 172169-1 Pin : 170359-1	Made by AMP
	With absolute encoder	Plug : 172171-1 Pin : 170359-1	Made by AMP

· Encoder plug

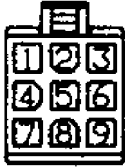

· Incremental Encoder Wiring Specifications

1	A channel output	Blue
2	/A channel output	White /Blue
3	B channel output	Yellow
4	/B channel output	White /Yellow
5	C channel output	Green
6	/C channel output	White /Green
7	0 V (Power supply)	Black
8	+5 VDC (Power supply)	Red
9	FG (Frame ground)	Green /Yellow

· Encoder plug

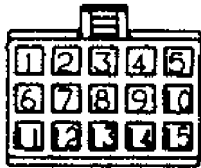

· 12-bit Absolute Encoder (1024 P/R) Wiring Specifications

1	A channel output	Blue
2	/A channel output	White /Blue
3	B channel output	Yellow
4	/B channel output	White /Yellow
5	Z (C) channel output	Green
6	/Z (/C) channel output	White /Green
7	0 V (Power supply)	Black
8	+5 VDC (Power supply)	Red
9	FG (Frame ground)	Green /Yellow
10	S channel output	Purple
11	/S channel output	White /Purple
* (12)	(Capacitor reset)	(Grey)
13	Reset	White /Grey
14	0 V (Battery)	White /Orange
15	3.6 V (Battery)	Orange

* Terminal to discharge capacitor for product dispatch. Do not use.

上正科技有限公司
 購買、維修 此手冊零件
 電話： 037-466333
 Email: service@repairtw.com
 Line id: @zzz
 www.repairtw.com

· 15-bit Absolute Encoder (8192 P/R) Wiring Specifications

· Encoder plug

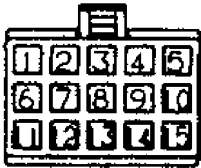

1	A channel output	Blue
2	/A channel output	White /Blue
3	B channel output	Yellow
4	/B channel output	White /Yellow
5	Z (C) channel output	Green
6	/Z (/C) channel output	White /Green
7	0 V (Power supply)	Black
8	+5 VDC (Power supply)	Red
9	FG (Frame ground)	Green /Yellow
10	-	-
11	-	-
(12)	-	-
13	Reset	White /Grey
14	0 V (Battery)	White /Orange
15	3.6 V (Battery)	Orange

上正科技有限公司

購買、維修 此手冊零組件

電話： 037-466333

Email: service@repairtw.com

Line id: @zzzz

www.repairtw.com

5.3 SERVOPACK Ratings and Specifications

This section presents tables of SGDB SERVOPACK ratings and specifications.

5.3.1 Combined Specifications

The following table shows the specifications obtained when SGDB SERVOPACKs are combined with SGMG, SGMS, SGMD and SGMP servomotors:

SG MG Series	SERVOPACK SGDB-		03ADM	07ADM	10ADM	15ADM	20ADM	30ADM	44ADM	60ADM		
	Motor	Type	03A□B	06A□B	09A□B	12A□B	20A□B	30A□B	44A□B	60A□B		
		SGMG-										
		Capacity kW (HP)	0.3 (0.4)	0.6 (0.8)	0.9 (1.2)	1.2 (1.6)	2.0 (2.7)	3.0 (4.0)	4.4 (5.9)	6.0 (8.0)		
	Rated/Max. Motor Speed r/min		1000/2000									
	Applicable Encoder		Standard: Incremental encoder (8192 P/R)									
	Continuous Output Current A (rms)		3.0	5.7	7.6	11.6	18.5	24.8	32.9	46.9		
	Max. Output Current A (rms)		7.3	13.9	16.6	28	42	56	84	110		
Allowable Load Inertia* J_L $\times 10^{-4} \text{ kg}\cdot\text{m}^2$ $(\times 10^{-3} \text{ oz}\cdot\text{in}\cdot\text{s}^2)$		36.2 (32.0)	69.5 (61.5)	103 (91.2)	159 (141)	230 (204)	338 (299)	445 (394)	625 (553)			

上正科技有限公司
 購買・維修・此手冊零組件
 電話：037-466333
 Email: service@repairtw.com
 Line id: @zzzz
 www.repairtw.com

SG MG Series	SERVOPACK SGDB-		05 ADG	10 ADG	15 ADG	20 ADG	30 ADG	44 ADG		60 ADG	75 ADG	1A ADG	1E ADG	
	Motor	Type SGMG-	05 A□A	09 A□A	13 A□A	20 A□A	30 A□A	44 A□A			55 A□A	75 A□A	1A A□A	1E A□A
		Capacity kW (HP)	0.45 (0.6)	0.85 (1.1)	1.3 (1.7)	1.8 (2.4)	2.9 (3.9)	4.4 (5.9)			5.5 (7.4)	7.5 (10)	11 (15)	15 (20)
		Rated/Max Motor Speed r/min	1500/3000										/2000	
Applicable Encoder	Standard: Incremental encoder (8192 P/R)													
Continuous Output Current A (rms)	3.8	7.1	10.7	16.7	23.8	32.8			42.1	54.7	58.6	78.0		
Max. Output Current A (rms)	11	17	28	42	56	84			110	130	140	170		
Allowable Load Inertia* J_L $\times 10^{-4}$ kg·m ² ($\times 10^{-3}$ oz·in·s ²)	36.2 (32.0)	69.5 (61.5)	103 (91.2)	159 (141)	230 (204)	338 (299)			445 (394)	625 (553)	1405 (1244)	1575 (1395)		
SG MD Series	SERVOPACK SGDB-						30 ADD	44 ADD	50 ADD					
	Motor	Type SGMD-					22 A□A	32 A□A	40 A□A					
		Capacity kW (HP)					2.2 (2.9)	3.2 (4.3)	4.0 (5.4)					
		Rated/Max Motor Speed r/min	2000/3000											
	Applicable Encoder	Standard: Absolute encoder (1024 P/R) @repairtw.com												
	Continuous Output Current A (rms)						15.7	20.9	22.8					
Max. Output Current A (rms)						54	73	77						
Allowable Load Inertia* J_L $\times 10^{-4}$ kg·m ² ($\times 10^{-3}$ oz·in·s ²)						255 (226)	343 (304)	431 (382)						

*Allowable load inertia is five times the motor inertia for SGMG and SGMD.

SERVO SELECTION AND DATA SHEETS

5.3.1 Combined Specifications cont.

SG MS Series	SERVOPACK SGDB-			10ADS	15ADS	20ADS	30ADS	44ADS	50ADS			
	Motor	Type SGMS-		10 A□A	15 A□A	20 A□A	30 A□A	40 A□A	50 A□A			
		Capacity kW (HP)		1.0 (1.3)	1.5 (2.0)	2.0 (2.7)	3.0 (4.0)	4.0 (5.4)	5.0 (6.7)			
	Rated/Max. Motor Speed r/min		3000/4500									
	Applicable Encoder		Standard: Incremental encoder (4096 P/R)									
	Continuous Output Current A (rms)			5.7	9.5	12.4	18.8	24.3	28.2			
	Max. Output Current A (rms)			17	28	42	56	77	84			
	Allowable Load Inertia* J_L $\times 10^{-4} \text{ kg}\cdot\text{m}^2$ $(\times 10^{-3} \text{ oz}\cdot\text{in}\cdot\text{s}^2)$			8.7 (7.7)	12.4 (11.0)	16.0 (14.2)	35.0 (31.0)	48.0 (42.5)	61.5 (54.9)			
SG MP Series	SERVOPACK SGDB-		05ADP	10ADP	15ADP							
	Motor	Type SGMP-	04A	08A	15A□							
		Capacity kW (HP)	0.4 (0.54)	0.75 (1.01)	1.5 (2.0)							
	Rated/Max. Motor Speed r/min		3000/4500									
	Applicable Encoder		Standard: Incremental encoder (2048 P/R) Email: service@repairtw.com									
	Continuous Output Current A (rms)		2.6	4.1	7.5							
	Max. Output Current A (rms)		8.0	13.9	23.0							
	Allowable Load Inertia* J_L $\times 10^{-4} \text{ kg}\cdot\text{m}^2$ $(\times 10^{-3} \text{ oz}\cdot\text{in}\cdot\text{s}^2)$		3.5 (49.6)	10.6 (150)	20.2 (286)							

*Allowable load inertia is five times the motor inertia for SGMS and SGMP.

5.3.2 Ratings and Specifications

The ratings and specifications of the SGDB SERVOPACK are shown below. Refer to them as required when selecting a SERVOPACK.

SERVOPACK SGDB-			03	05	07	10	15	20	30	44	50	60	75	1A	1E	
Servomotor	SGMG- (1500 r/min)		–	05A	–	09A	13A	20A	30A	44A	–	55A	75A	1AA	1EA	
	SGMG- (1000 r/min)		03A	–	06A	09A	12A	20A	30A	44A	–	60A	–	–	–	
	SGMS-		–	–	–	10A	15A	20A	30A	40A	50A	–	–	–	–	
	SGMD-		–	–	–	–	–	–	22A	32A	40A	–	–	–	–	
	SGMP-		–	04A	–	08A	15A	–	–	–	–	–	–	–	–	
	SGM-		–	04A	–	08A	–	–	–	–	–	–	–	–	–	
Basic Specifications	Input Power Supply	Main Circuit*1	Three-phase 200 to 230 VAC +10% to –15%, 50/60 Hz													
		Control Circuit*1	Single-phase 200 to 230 VAC +10% to –15%, 50/60 Hz													
	Control Mode		Three-phase, full-wave rectification IGBT PWM (sine-wave driven)													
	Feedback		Incremental encoder, absolute encoder													
	Location	Ambient/Storage Temp.*2		0 to 55°C/–20 to 85°C												
		Ambient/Storage Humidity		90% or less (no-condensing)												
		Vibration/Shock Resistance		4.9m/s ² /19.6m/s ²												
	Structure		Base mounted (duct ventilation available as option)													
Approx. mass		kg(lb)	4 (9)				5 (11)			8 (18)		15 (33)		23 (51)		
Speed/Torque Control Mode	Performance	Speed Control Range		1:5000 (provided that the lower limit of the speed control range does not cause the motor to stop when the rated torque load is applied)												
		Speed Regulation*3	Load Regulation	0% to 100%: 0.01% max. (at rated speed)												
			Voltage Regulation	Rated voltage ±10%: 0% (at rated speed)												
			Temperature Regulation	25±25°C: 0.1% max. (at rated speed)												
		Frequency Characteristics		250Hz (at $J_L=J_M$)												
		Torque Control (Repeatability)		±2.0%												
		Soft Start Time Setting		0 to 10 s (each for acceleration and deceleration)												
	Input Signal	Speed Reference	Reference Voltage*4	±6 VDC (variable setting range: ±2 to ±10 VDC) at rated speed (forward rotation with positive reference)												
			Input Impedance	Approx. 30 kΩ												
			Circuit Time Constant	Approx. 47 μs												
Torque Reference		Reference Voltage*4	±1 to ±10 VDC at rated speed (forward rotation with positive reference)													

SERVO SELECTION AND DATA SHEETS

5.3.2 Ratings and Specifications cont.

SERVOPACK SGDB-				03	05	07	10	15	20	30	44	50	60	75	1A	1E
Speed/ Torque Control Mode	Input Signal	Torque Refer- ence	Input Im- pedance	Approx. 30 kΩ												
Speed/ Torque Control Mode	Input Signal	Torque Refer- ence	Circuit Time Constant	Approx. 47 μs												
		Built-in Reference Power Supply		±12 V, ±30 mA												
		Contact Speed Refer- ence	Rotation Direction Selection	Uses P control signal												
			Speed Selection	Forward/reverse rotation current control signals are used (1st to 3rd speed selection). When both signals are OFF, the motor stops or enters another control mode.												
Position Control Mode	Per- form- ance	Bias Setting		0 to 450 r/min (setting resolution: 1 r/min)												
		Feed-forward Com- pensation		0 to 100% (setting resolution: 1%)												
		Position Complete Width Setting		0 to 250 reference units (setting resolution: 1 reference unit)												
	Input Signal	Refer- ence Pulse	Type	SIGN + PULSE train, 90° phase difference 2-phase pulse (phase A + phase B), or CCW + CW pulse train												
			Pulse Buffer	Line driver (+5 V level), open collector (+5 V or +12 V level)												
			Pulse Frequen- cy	Max. 450/200 kpps (line driver/open collector)												
		Control Signal		CLEAR (input pulse form identical to reference pulse)												
Built-in Open Collec- tor Power Supply*5		+12 V (with built-in 1 kΩ resistor)														
I/O Sig- nals	Position Output	Output Form	Phases A, B and C: Line driver output Phase S: Line driver output (only when 12-bit absolute encoder is used)													
		Frequen- cy Divid- ing Ratio	(16 to N)/N (N: Number of encoder pulses)													
	Sequence Input		Servo ON, P control (or forward/reverse rotation in contact input speed control mode), forward rotation prohibited (P-OT), reverse rotation prohibited (N-OT), alarm reset, forward rotation current limit, and reverse rotation current limit (or contact input speed control)													
	Sequence Output			Servo alarm, 3-bit alarm codes												
		Any 3 of those signals		Positioning complete (speed coincidence), TGON, servo ready, current limit, brake release, overload warning, overload detected												
	Analog Monitor Output	Any 2 of those signals		Speed: 2 V/1000 r/min or 1 V/1000 r/min Torque: 2 V/rated torque Error: 0.05 V/reference unit or 0.05 V/100 reference units												
Built-in Func- tions	Dynamic Brake (DB)		Activated at main power OFF, servo alarm, servo OFF or overtravel													
	Regenerative Processing		Incorporated. For 60 to 1A types, external regenerative resistor must be mounted.													
	Overtravel (OT) Prevention		Motor is stopped by dynamic brake, decelerates to a stop, or coasts to a stop when P-OT or N-OT is activated.													
	Protection		Overcurrent, overload, regenerative error, main circuit voltage error, heat sink overheat, power open phase, overflow, overspeed, encoder error, encoder disconnected, overrun, CPU error, parameter error													
	LED Display		POWER, ALARM, CHARGE													
	Analog Monitor (5CN)		Same analog monitor signal as 1CN is available.													

SERVOPACK SGDB-			03	05	07	10	15	20	30	44	50	60	75	1A	1E
Built-in Functions	Com-mu-nica-tion	Interface	Digital Operator (mount type or hand type) RS422A port such as personal computer (RS232C port can be used if some conditions are met.)												
		1:N Communication	N can be up to 14 when RS422A port is used.												
		Axis Address Setting*6	Hexadecimal rotary switch (1SW) 1: 1:N communication, 0: 1:1 communication												
	Functions	Status display, user constant setting, monitor display, alarm traceback display, jogging, autotuning, etc.													
	Others	Zero-clamp, reverse rotation connection													

*1 The power voltage must not exceed 230 V + 10% (253 V). If it is likely to exceed this limit, use a step-down transformer.

*2 The ambient temperature must be within the specified range. Even if the SERVOPACK is installed in a box, the temperature inside the box must not exceed the range.

*3 Speed regulation can be calculated using the following formula:

$$\left(\text{Speed regulation} = \frac{(\text{no-load motor speed} - \text{full-load motor speed})}{\text{rated motor speed}} \times 100\% \right)$$

Under actual operating conditions, voltage or temperature fluctuation causes drift to the amplifier or changes the operating resistance, resulting in the motor speed being changed.

The percentage of the motor speed change to the rated motor speed is called "speed regulation".

*4 Forward rotation is defined as the clockwise rotation when viewed from the motor on the opposite side of the load. (It is the counterclockwise rotation when viewed from the load or shaft.)

*5 Built-in open collector power supply is not electrically isolated from the control circuit inside the SERVOPACK.

*6 For 1:1 communication, set the rotary switch to "0".

5.3.3 Overload Characteristics

The SERVOPACK has a built-in overload protective function to protect the SERVOPACK and servomotor from overload. Therefore, the SERVOPACK allowable power is limited by the overload protective function, as shown below.

The overload detection level is quoted under **hot start** conditions at a motor ambient temperature of 40°C.

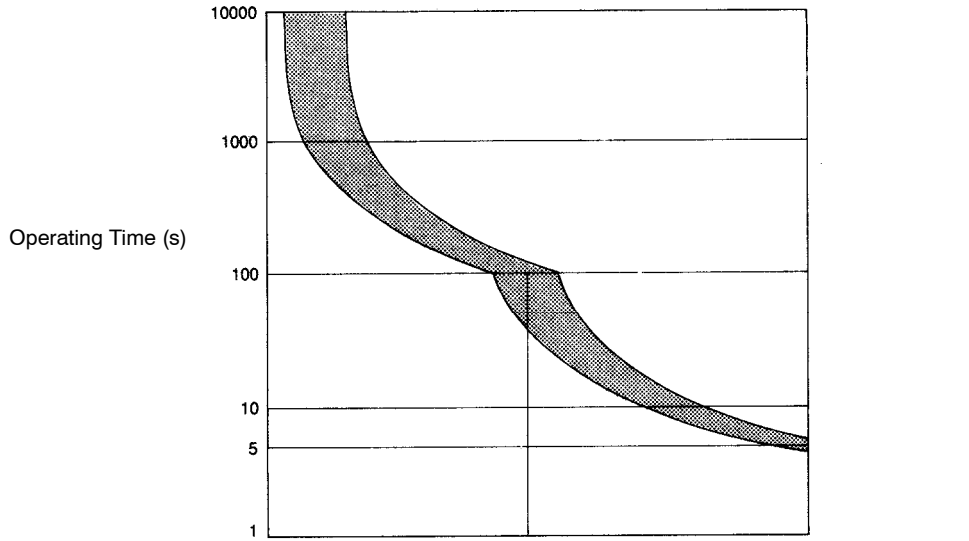

5

上正科技有限公司
 購買、維修 此手冊零組件
 電話： 037-466333
Overload Characteristics
 Email: service@repairtw.com
 Line id: @zzzz
 www.repairtw.com



Hot Start

Indicates that both SERVOPACK and servomotor have run long enough at rated load to be thermally saturated.

5.3.4 Starting Time and Stopping Time

The motor starting time (t_r) and stopping time (t_f) under constant load are calculated by the following formulas. The motor viscous torque and friction torque are ignored.

$$\text{Starting Time: } t_r = \frac{2\pi \cdot N_m (J_M + J_L)}{60 \cdot (T_{PM} - T_L)} \quad [\text{s}]$$

$$\text{Stopping Time: } t_f = \frac{2\pi \cdot N_m (J_M + J_L)}{60 \cdot (T_{PM} + T_L)} \quad [\text{ms}]$$

N_M : Motor speed used (r/min.)

J_M : Motor moment of inertia ($\text{kg}\cdot\text{m}^2$) ($\text{GD}^2_M/4$)

J_L : Load converted to shaft moment of inertia ($\text{kg}\cdot\text{m}^2$) ($\text{GD}^2_L/4$)

T_{PM} : Maximum instantaneous motor torque obtained in combination with SERVOPACK (N·m)

T_L : Load torque (N·m)

To convert the motor current value into an equivalent torque value, use the following formula:

Motor torque constant \times motor current value (effective value)

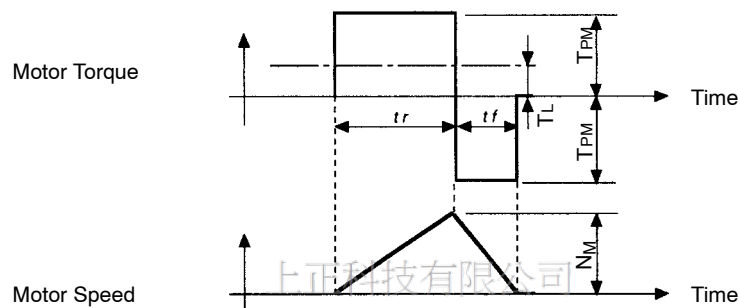

Motor Torque (size) - Motor Speed Timing Chart

電話：037-466333

Email: service@repairtw.com

Line id: @zzzz

www.repairtw.com

5.3.5 Load Inertia

The larger the load inertia becomes, the worse the movement response of the load. The size of the load inertia (J_L) allowable when using a servomotor must not exceed five times the motor inertia (J_M).

If the load inertia exceeds five times the motor inertia, an overvoltage alarm may arise during deceleration. To prevent this, take one of the following actions:

- Reduce the torque limit value.
- Reduce the slope of the deceleration curve.
- Reduce the maximum motor speed.
- Consult your Yaskawa representative.

上正科技有限公司

購買、維修 此手冊零組件

電話： 037-466333

Email: service@repairtw.com

Line id: @zzzz

www.repairtw.com

5.3.6 Overhanging Loads

A servomotor may not be operated under an overhanging load, that is a load which tends to continually rotate the motor.

- Overhanging Load Example 1: Motor drive for vertical axis, using no counterweight

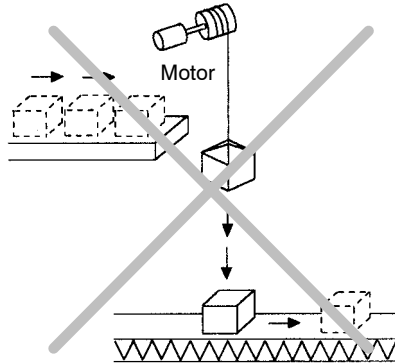

- Overhanging Load Example 2: Tension control drive

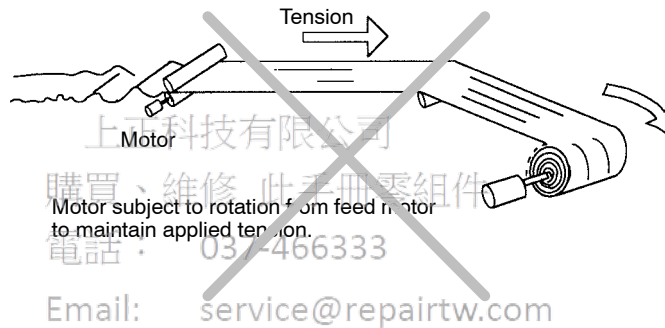

NOTE Under an overhanging load (e.g. when the direction of the torque applied by the motor is opposite from the direction of shaft rotation), the SERVOPACK regenerative brake is applied continuously and the regenerative energy of the load may exceed the allowable range and damage the SERVOPACK.

The regenerative brake capacity of the SGDB SERVOPACK is rated for short-time operation, approximately equivalent to the deceleration stopping time.

5.4 Σ-Series Dimensional Drawings

This section presents dimensional drawings of the Σ-Series servomotor, SERVOPACK, and Digital Operator.

5.4.1 Servomotor Dimensional Drawings

The dimensional drawings of the SGMG, SGMS, SGMD and SGMP (1.5 kW) servomotors are shown on the following pages.

Note that the types and dimensional drawings of the SGMG servomotors differ according to rated speed (1500 or 1000 min⁻¹).

The dimensional drawings of each servomotor series are broadly divided into four types, according to the detector type (incremental or absolute encoder) and the presence or absence of a brake.

- SGMG servomotor (1500 min⁻¹) page 293
- SGMG servomotor (1000 min⁻¹) page 327
- SGMS servomotor page 359
- SGMD servomotor page 378
- SGMP servomotor (1.5kW) page 390
- SGM/SGMP servomotor (400W, 750W) Refer to USER'S MANUAL (Manual No. TSE-S800-15 or S800-17).

上正科技有限公司
 購買、維修 此手冊零組件
 電話：037-466333

Email: service@repairtw.com
 Line id: @zzzz
www.repairtw.com

■ SGMG-□□□A Servomotor (1500 min⁻¹)

Incremental encoder (8192 P/R)

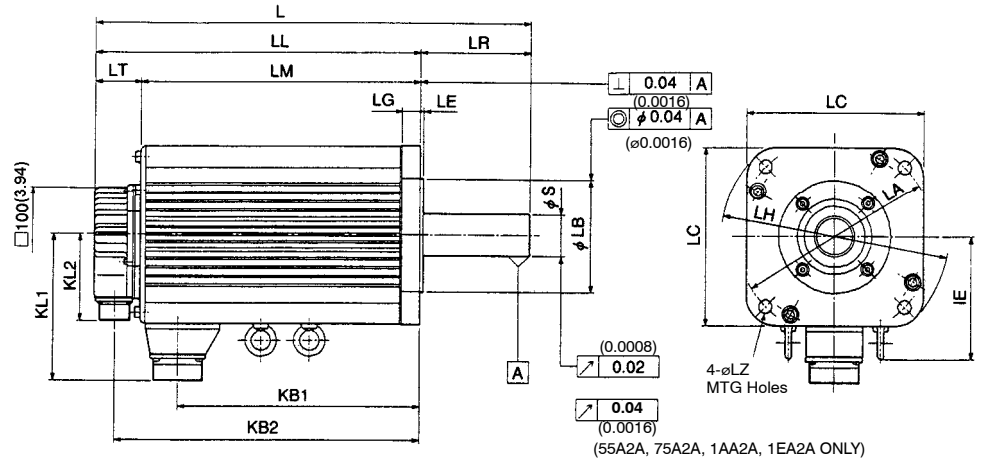

Detailed View of Shaft End for SGMG-05A2A to -13A2A, -1AA2A and -1EA2A

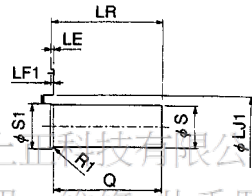

Detailed View of Shaft End for SGMG-20A2A to -75A2A

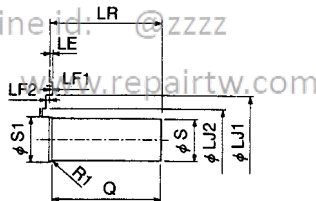

5

購買、維修 此手冊零組件

電話： 037-466333

Email: service@repairtw.com

Line id: @zzzz

www.repairtw.com

in mm (inches)

Type SGMG-	L	LL	LM	LR	LT	KB1	KB2	IE	KL1	KL2
05A2A	196 (7.72)	138 (5.43)	92 (3.62)	58 (2.28)	46 (1.81)	65 (2.56)	117 (4.61)	-	109 (4.29)	88 (3.46)
09A2A	219 (8.62)	161 (6.34)	115 (4.53)	58 (2.28)	46 (1.81)	88 (3.46)	140 (5.51)	-	109 (4.29)	88 (3.46)
13A2A	243 (9.57)	185 (7.28)	139 (5.47)	58 (2.28)	46 (1.81)	112 (4.41)	164 (6.46)	-	109 (4.29)	88 (3.46)
20A2A	245 (9.65)	166 (6.54)	119 (4.69)	79 (3.11)	47 (1.85)	89 (3.50)	145 (5.71)	-	140 (5.51)	88 (3.46)
30A2A	271 (10.67)	192 (7.56)	145 (5.71)	79 (3.11)	47 (1.85)	115 (4.53)	171 (6.73)	-	140 (5.51)	88 (3.46)
44A2A	305 (12.01)	226 (8.90)	179 (7.05)	79 (3.11)	47 (1.85)	149 (5.87)	205 (8.07)	-	140 (5.51)	88 (3.46)
55A2A	373 (14.69)	260 (10.24)	213 (8.39)	113 (4.45)	47 (1.85)	174 (6.85)	239 (9.41)	125 (4.92)	150 (5.91)	88 (3.46)
75A2A	447 (17.60)	334 (13.15)	287 (11.30)	113 (4.45)	47 (1.85)	248 (9.76)	313 (12.32)	125 (4.92)	150 (5.91)	88 (3.46)
1AA2A	454 (17.87)	338 (13.31)	291 (11.46)	116 (4.57)	47 (1.85)	251 (9.88)	317 (12.48)	142 (5.59)	168 (6.61)	88 (3.46)
1EA2A	573 (22.56)	457 (17.99)	388 (15.28)	116 (4.57)	69 (2.72)	343 (13.50)	435 (17.13)	142 (5.59)	168 (6.61)	88 (3.46)

上正科技有限公司

購買、維修 此手冊零組件

電話： 037-466333

Email: service@repairtw.com

Line id: @zzzz

www.repairtw.com

in mm (inches)

Type SGMG-	Flange dimensions										
	LA	LB	LC	LE	LF1	LF2	LG	LH	LJ1	LJ2	LZ
05A2A	145 (5.71)	$110 \begin{matrix} 0 \\ - 0.035 \\ 0 \\ (4.33 - 0.0014) \end{matrix}$	130 (5.12)	6 (0.24)	6 (0.24)	-	12 (0.47)	165 (6.50)	45 (1.77)	-	9 (0.35)
09A2A	145 (5.71)	$110 \begin{matrix} 0 \\ - 0.035 \\ 0 \\ (4.33 - 0.0014) \end{matrix}$	130 (5.12)	6 (0.24)	6 (0.24)	-	12 (0.47)	165 (6.50)	45 (1.77)	-	9 (0.35)
13A2A	145 (5.71)	$110 \begin{matrix} 0 \\ - 0.035 \\ 0 \\ (4.33 - 0.0014) \end{matrix}$	130 (5.12)	6 (0.24)	6 (0.24)	-	12 (0.47)	165 (6.50)	45 (1.77)	-	9 (0.35)
20A2A	200 (7.87)	$114.3 \begin{matrix} 0 \\ - 0.025 \\ 0 \\ (4.50 - 0.0010) \end{matrix}$	180 (7.09)	3.2 (0.13)	3 (0.12)	0.5 (0.0197)	18 (0.71)	230 (9.06)	76 (2.99)	62 (2.44)	13.5 (0.53)
30A2A	200 (7.87)	$114.3 \begin{matrix} 0 \\ - 0.025 \\ 0 \\ (4.50 - 0.0010) \end{matrix}$	180 (7.09)	3.2 (0.13)	3 (0.12)	0.5 (0.0197)	18 (0.71)	230 (9.06)	76 (2.99)	62 (2.44)	13.5 (0.53)
44A2A	200 (7.87)	$114.3 \begin{matrix} 0 \\ - 0.025 \\ 0 \\ (4.50 - 0.0010) \end{matrix}$	180 (7.09)	3.2 (0.13)	3 (0.12)	0.5 (0.0197)	18 (0.71)	230 (9.06)	76 (2.99)	62 (2.44)	13.5 (0.53)
55A2A	200 (7.87)	$114.3 \begin{matrix} 0 \\ - 0.025 \\ 0 \\ (4.50 - 0.0010) \end{matrix}$	180 (7.09)	3.2 (0.13)	3 (0.12)	0.5 (0.0197)	18 (0.71)	230 (9.06)	76 (2.99)	62 (2.44)	13.5 (0.53)
75A2A	200 (7.87)	$114.3 \begin{matrix} 0 \\ - 0.025 \\ 0 \\ (4.50 - 0.0010) \end{matrix}$	180 (7.09)	3.2 (0.13)	3 (0.12)	0.5 (0.0197)	18 (0.71)	230 (9.06)	76 (2.99)	62 (2.44)	13.5 (0.53)
1AA2A	235 (9.25)	$200 \begin{matrix} 0 \\ - 0.046 \\ 0 \\ (7.87 - 0.0018) \end{matrix}$	220 (8.66)	4 (0.16)	4 (0.16)	18 (0.71)	270 (10.63)	62 (2.44)	-	13.5 (0.53)	
1EA2A	235 (9.25)	$200 \begin{matrix} 0 \\ - 0.046 \\ 0 \\ (7.87 - 0.0018) \end{matrix}$	220 (8.66)	4 (0.16)	4 (0.16)	20 (0.79)	270 (10.63)	85 (3.35)	-	13.5 (0.53)	

USING THE DIGITAL OPERATOR

5.4.1 Servomotor Dimensional Drawings cont.

in mm (inches)

Type SGMG-	Shaft end dimensions			Approx. mass kg (lb)
	S	S1	Q	
05A2A	$19 \begin{smallmatrix} 0 \\ - 0.013 \\ 0 \end{smallmatrix}$ (0.75 - 0.0005)	30 (1.18)	40 (1.57)	5.5 (12.12)
09A2A	$19 \begin{smallmatrix} 0 \\ - 0.013 \\ 0 \end{smallmatrix}$ (0.75 - 0.0005)	30 (1.18)	40 (1.57)	7.6 (16.75)
13A2A	$22 \begin{smallmatrix} 0 \\ - 0.013 \\ 0 \end{smallmatrix}$ (0.87 - 0.0005)	30 (1.18)	40 (1.57)	9.6 (21.16)
20A2A	$35 \begin{smallmatrix} + 0.01 \\ 0 \\ + 0.0004 \\ 0 \end{smallmatrix}$ (1.38 + 0.0004)	45 (1.77)	76 (2.99)	14 (30.86)
30A2A	$35 \begin{smallmatrix} + 0.01 \\ 0 \\ + 0.0004 \\ 0 \end{smallmatrix}$ (1.38 + 0.0004)	45 (1.77)	76 (2.99)	18 (39.68)
44A2A	$35 \begin{smallmatrix} + 0.01 \\ 0 \\ + 0.0004 \\ 0 \end{smallmatrix}$ (1.38 + 0.0004)	45 (1.77)	76 (2.99)	23 (50.69)
55A2A	$42 \begin{smallmatrix} 0 \\ - 0.016 \\ 0 \end{smallmatrix}$ (1.65 - 0.0006)	45 (1.77)	110 (4.33)	30 (66.13)
75A2A	$42 \begin{smallmatrix} 0 \\ - 0.016 \\ 0 \end{smallmatrix}$ (1.65 - 0.0006)	45 (1.77)	110 (4.33)	40 (88.18)
1AA2A	$42 \begin{smallmatrix} 0 \\ - 0.016 \\ 0 \end{smallmatrix}$ (1.65 - 0.0006)	45 (1.77)	110 (4.33)	57.5 (126.73)
1EA2A	$55 \begin{smallmatrix} + 0.030 \\ + 0.011 \\ + 0.0012 \\ + 0.0004 \end{smallmatrix}$ (2.17 + 0.0004)	65 (2.56)	110 (4.33)	86 (189.6)

Note 1) Incremental encoder (8192 P/R) is used as a detector.

2) SGMG-05A to -44A2A do not contain eyebolts.

• Connector Wiring on Detector Side

Receptacle: MS3102A20-29P

Plug (To be prepared by customer) (L type): MS3108B20-29S or
(Straight type) MS3106B20-29S

Cable Clamp: (To be prepared by customer) MS3057-12A

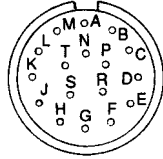

Encoder Wiring Specifications

A	A channel output	K	
B	/A channel output	L	
C	B channel output	M	
D	/B channel output	N	
E	C channel output	P	
F	/C channel output	R	
G	0V	S	
H	+5V DC	T	
J	FG (Frame Ground)		

Note 1) Terminals K to T are not used.

2) Receptacle, plug and cable clamp are common regardless of motor capacity.

• Connector Wiring on Motor Side

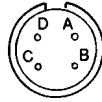

Motor Wiring Specifications

A	Phase U
B	Phase V
C	Phase W
D	Ground terminal

Note Receptacle, plug and cable clamp differ depending on the capacity. Refer to 6) Connectors on Detector and Motor Sides (page 392).

Incremental encoder (8192 P/R) with brake

- 0.5 to 4.4kW

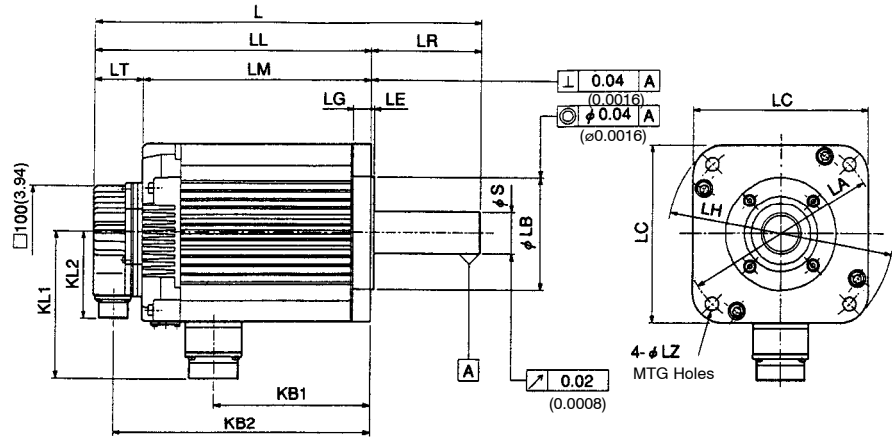

Detailed View of Shaft End for SGMG-05A2AAB to -13A2AAB

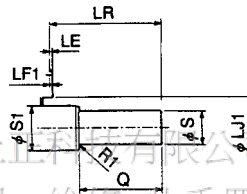

購買、維修 此手冊零組件

電話： 037-466333

Detailed View of Shaft End for SGMG-20A2AAB to -44A2AAB

Email: service@repairtw.com

Line id: @zzzz

www.repairtw.com

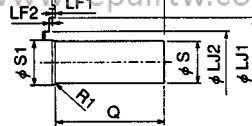

in mm (inches)

Type SGMG-	L	LL	LM	LR	LT	KB1	KB2	KL1	KL2
05A2AAB	234 (9.21)	176 (6.93)	129 (5.08)	58 (2.28)	47 (1.85)	56 (2.20)	155 (2.20)	120 (4.72)	88 (3.46)
09A2AAB	257 (10.12)	199 (7.83)	152 (5.98)	58 (2.28)	47 (1.85)	79 (3.11)	178 (7.01)	120 (4.72)	88 (3.46)
13A2AAB	281 (11.06)	223 (8.78)	176 (6.93)	58 (2.28)	47 (1.85)	103 (4.06)	202 (7.95)	120 (4.72)	88 (3.46)
20A2AAB	296 (11.65)	217 (8.54)	170 (6.69)	79 (3.11)	47 (1.85)	79 (3.11)	196 (7.72)	146 (5.75)	88 (3.46)
30A2AAB	322 (12.68)	243 (9.57)	196 (7.72)	79 (3.11)	47 (1.85)	105 (4.13)	222 (8.74)	146 (5.75)	88 (3.46)
44A2AAB	356 (14.02)	277 (10.91)	230 (9.06)	79 (3.11)	47 (1.85)	139 (5.47)	256 (10.08)	146 (5.75)	88 (3.46)

in mm (inches)

Type SGMG-	Flange dimensions										
	LA	LB	LC	LE	LF1	LF2	LG	LH	LJ1	LJ2	LZ
05A2AAB	145 (5.71)	110 ⁰ - 0.035 (4.33 - 0.0014)	130 (5.12)	6 (0.24)	6 (0.24)	-	12 (0.47)	165 (6.5)	45 (1.77)	-	9 (0.35)
09A2AAB	145 (5.71)	110 ⁰ - 0.035 (4.33 - 0.0014)	130 (5.12)	6 (0.24)	6 (0.24)	-	12 (0.47)	165 (6.5)	45 (1.77)	-	9 (0.35)
13A2AAB	145 (5.71)	110 ⁰ - 0.035 (4.33 - 0.0014)	130 (5.12)	6 (0.24)	6 (0.24)	-	12 (0.47)	165 (6.5)	45 (1.77)	-	9 (0.35)
20A2AAB	200 (7.87)	114.3 ⁰ - 0.025 (4.50 - 0.0010)	180 (7.09)	3.2 (0.13)	3 (0.12)	0.5 (0.0197)	18 (0.71)	230 (9.06)	76 (2.99)	62 (2.44)	13.5 (0.53)
30A2AAB	200 (7.87)	114.3 ⁰ - 0.025 (4.50 - 0.0010)	180 (7.09)	3.2 (0.13)	3 (0.12)	0.5 (0.0197)	18 (0.71)	230 (9.06)	76 (2.99)	62 (2.44)	13.5 (0.53)
44A2AAB	200 (7.87)	114.3 ⁰ - 0.025 (4.50 - 0.0010)	180 (7.09)	3.2 (0.13)	3 (0.12)	0.5 (0.0197)	18 (0.71)	230 (9.06)	76 (2.99)	62 (2.44)	13.5 (0.53)

USING THE DIGITAL OPERATOR

5.4.1 Servomotor Dimensional Drawings cont.

in mm (inches)

Type SGMG-	Shaft end dimensions			Approx. mass kg (lb)
	S	S1	Q	
05A2AAB	$19 \begin{smallmatrix} 0 \\ - 0.013 \\ 0 \\ (0.75 - 0.0005) \end{smallmatrix}$	30 (1.18)	40 (1.57)	7.5 (16.53)
09A2AAB	$19 \begin{smallmatrix} 0 \\ - 0.013 \\ 0 \\ (0.75 - 0.0005) \end{smallmatrix}$	30 (1.18)	40 (1.57)	9.6 (21.16)
13A2AAB	$22 \begin{smallmatrix} 0 \\ - 0.013 \\ 0 \\ (0.87 - 0.0005) \end{smallmatrix}$	30 (1.18)	40 (1.57)	12 26.45
20A2AAB	$35 \begin{smallmatrix} + 0.01 \\ 0 \\ + 0.0004 \\ 0 \end{smallmatrix}$ (1.38)	45 (1.77)	76 (2.99)	19 (41.88)
30A2AAB	$35 \begin{smallmatrix} + 0.01 \\ 0 \\ + 0.0004 \\ 0 \end{smallmatrix}$ (1.38)	45 (1.77)	76 (2.99)	23.5 (51.79)
44A2AAB	$35 \begin{smallmatrix} + 0.01 \\ 0 \\ + 0.0004 \\ 0 \end{smallmatrix}$ (1.38)	45 (1.77)	76 (2.99)	28.5 (62.81)

Note Incremental encoder (8192 P/R) is used as a detector.

- Connector Wiring on Motor Side

A	Phase U	E	Brake terminal
B	Phase V	F	Brake terminal
C	Phase W	G	-
D	Frame ground (FG)		

• 5.5 to 15kW

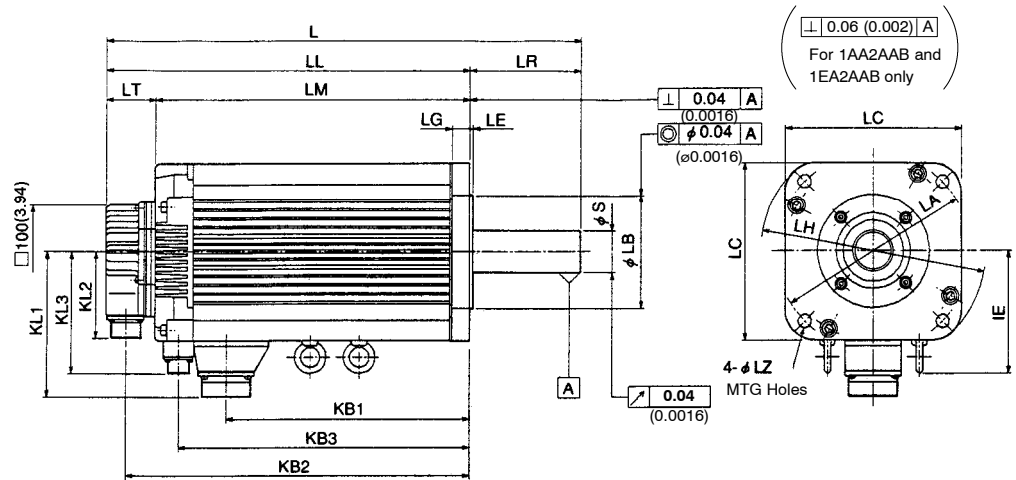

Detailed View of Shaft End for SGMG-55A2AAB and -75A2AAB

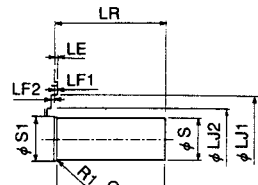

Detailed View of Shaft End for SGMG-1AA2AAB and -1EA2AAB

上正科技有限公司
 購買、維修 此手冊零組件
 電話：037-466333
 Email: service@repairtw.com
 Line id: @zzzz
 www.repairtw.com

in mm (inches)

Type SGMG-	L	LL	LM	LR	LT	KB1	KB2	KB3	IE	KL1	KL2	KL3
55A2AAB	424 (16.69)	311 (12.24)	264 (10.39)	113 (4.45)	47 (1.85)	174 (6.85)	290 (11.42)	231 (9.09)	125 (4.92)	150 (5.91)	88 (3.46)	123 (4.84)
75A2AAB	498 (19.61)	385 (15.16)	338 (13.31)	113 (4.45)	47 (1.85)	248 (9.76)	364 (14.33)	305 (12.01)	125 (4.92)	150 (5.91)	88 (3.46)	123 (4.84)
1AA2AAB	499 (19.65)	383 (15.08)	340 (13.39)	116 (4.57)	43 (1.69)	258 (10.16)	362 (14.25)	315 (12.40)	142 (5.59)	168 (6.61)	88 (3.46)	142 (5.59)
1EA2AAB	635 (25.00)	519 (20.43)	473 (18.62)	116 (4.57)	46 (1.81)	343 (13.50)	497 (19.57)	415 (16.34)	142 (5.59)	168 (6.61)	88 (3.46)	142 (5.59)

USING THE DIGITAL OPERATOR

5.4.1 Servomotor Dimensional Drawings cont.

in mm (inches)

Type SGMG-	Flange dimensions										
	LA	LB	LC	LE	LF1	LF2	LG	LH	LJ1	LJ2	LZ
55A2AAB	200 (7.87)	114.3 ⁰ _{-0.025} (4.50 ⁰ _{-0.0010})	180 (7.09)	3.2 (0.13)	3 (0.12)	0.5 (0.0197)	18 (0.71)	230 (9.06)	76 (2.99)	62 (2.44)	13.5 (0.53)
75A2AAB	200 (7.87)	114.3 ⁰ _{-0.025} (4.50 ⁰ _{-0.0010})	180 (7.09)	3.2 (0.13)	3 (0.12)	0.5 (0.0197)	18 (0.71)	230 (9.06)	76 (2.99)	62 (2.44)	13.5 (0.53)
1AA2AAB	235 (9.25)	200 ⁰ _{-0.046} (7.87 ⁰ _{-0.0018})	220 (8.66)	4 (0.16)	4 (0.16)	-	18 (0.71)	270 (10.63)	62 (2.44)	-	13.5 (0.53)
1EA2AAB	235 (9.25)	200 ⁰ _{-0.046} (7.87 ⁰ _{-0.0018})	220 (8.66)	4 (0.16)	4 (0.16)	-	20 (0.79)	270 (10.63)	85 (3.35)	-	13.5 (0.53)

in mm (inches)

Type SGMG-	Shaft end dimensions			Approx. mass kg (lb)
	S	S1	Q	
55A2AAB	42 ⁰ _{-0.016} (1.65 ⁰ _{-0.0006})	45 (1.77)	110 (4.33)	35 (77.14)
75A2AAB	42 ⁰ _{-0.016} (1.65 ⁰ _{-0.0006})	45 (1.77)	110 (4.33)	45.5 (100.28)
1AA2AAB	42 ⁰ _{-0.016} (1.65 ⁰ _{-0.0006})	45 (1.77)	110 (4.33)	65 (143.26)
1EA2AAB	55 ^{+0.030} _{+0.011} (2.17 ^{+0.0012} _{+0.0004})	65 (2.56)	110 (4.33)	100 (220.47)

Note Incremental encoder (8192 P/R) is used as a detector.

- Connector Wiring on Brake and Motor Sides



A	Brake terminal
B	Brake terminal
C	

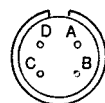

A	Phase U
B	Phase V
C	Phase W
D	Frame ground (FG)

Absolute encoder (15bit : 8192 P/R, 12 bit : 1024 P/R)

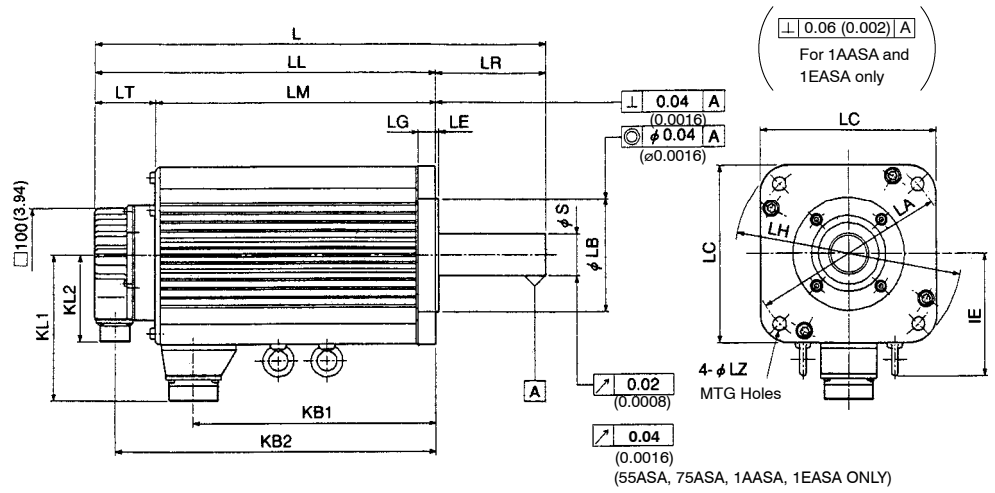

Detailed View of Shaft End for SGMG-05ASA to -13ASA, -1AASA and -1EASA

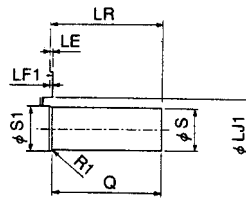

上正科技有限公司

Detailed View of Shaft End for SGMG-20ASA to -75ASA

電話： 037-466333

Email: service@repairtw.com

Line id: 222222

www.repairtw.com

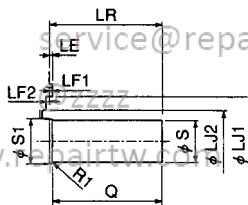

5

in mm (inches)

Type SGMG-	L	LL	LM	LR	LT	KB1	KB2	IE	KL1	KL2
05ASA	210 (8.27)	152 (5.98)	92 (3.62)	58 (2.28)	60 (2.36)	65 (2.56)	131 (5.16)	-	109 (4.29)	88 (3.46)
09ASA	233 (9.17)	175 (6.89)	115 (4.53)	58 (2.28)	60 (2.36)	88 (3.46)	154 (6.06)	-	109 (4.29)	88 (3.46)
13ASA	257 (10.12)	199 (7.83)	139 (5.47)	58 (2.28)	60 (2.36)	112 (4.41)	178 (7.01)	-	109 (4.29)	88 (3.46)
20ASA	259 (10.20)	180 (7.09)	119 (4.69)	79 (3.11)	61 (2.40)	89 (3.50)	159 (6.26)	-	140 (5.51)	88 (3.46)
30ASA	285 (11.22)	206 (8.11)	145 (5.71)	79 (3.11)	61 (2.40)	115 (4.53)	185 (7.28)	-	140 (5.51)	88 (3.46)
44ASA	319 (12.56)	240 (9.45)	179 (7.05)	79 (3.11)	61 (2.40)	149 (5.87)	219 (8.62)	-	140 (5.51)	88 (3.46)
55ASA	387 (15.24)	274 (10.79)	213 (8.39)	113 (4.45)	61 (2.40)	174 (6.85)	253 (9.96)	125 (4.92)	150 (5.91)	88 (3.46)
75ASA	461 (18.15)	348 (13.70)	287 (11.30)	113 (4.45)	61 (2.40)	248 (9.76)	327 (12.87)	125 (4.92)	150 (5.91)	88 (3.46)
1AASA	468 (18.43)	352 (13.86)	291 (11.46)	116 (4.57)	61 (2.40)	251 (9.88)	331 (13.03)	142 (5.59)	168 (6.61)	88 (3.46)
1EASA	587 (23.11)	471 (18.54)	388 (15.28)	116 (4.57)	83 (3.27)	343 (13.50)	449 (17.68)	142 (5.59)	168 (6.61)	88 (3.46)

上正科技有限公司

購買、維修 此手冊零組件

電話： 037-466333

Email: service@repairtw.com

Line id: @zzzz

www.repairtw.com

in mm (inches)

Type SGMG-	Flange dimensions										
	LA	LB	LC	LE	LF1	LF2	LG	LH	LJ1	LJ2	LZ
05ASA	145 (5.71)	110 ⁰ _{-0.035} (4.33 ⁰ _{-0.0014})	130 (5.12)	6 (0.24)	6 (0.24)	-	12 (0.47)	165 (6.50)	45 (1.77)	-	9 (0.35)
09ASA	145 (5.71)	110 ⁰ _{-0.035} (4.33 ⁰ _{-0.0014})	130 (5.12)	6 (0.24)	6 (0.24)	-	12 (0.47)	165 (6.50)	45 (1.77)	-	9 (0.35)
13ASA	145 (5.71)	110 ⁰ _{-0.035} (4.33 ⁰ _{-0.0014})	130 (5.12)	6 (0.24)	6 (0.24)	-	12 (0.47)	165 (6.50)	45 (1.77)	-	9 (0.35)
20ASA	200 (7.87)	114.3 ⁰ _{-0.025} (4.50 ⁰ _{-0.0010})	180 (7.09)	3.2 (0.13)	3 (0.12)	0.5 (0.0197)	18 (0.71)	230 (9.06)	76 (2.99)	62 (2.44)	13.5 (0.53)
30ASA	200 (7.87)	114.3 ⁰ _{-0.025} (4.50 ⁰ _{-0.0010})	180 (7.09)	3.2 (0.13)	3 (0.12)	0.5 (0.0197)	18 (0.71)	230 (9.06)	76 (2.99)	62 (2.44)	13.5 (0.53)
44ASA	200 (7.87)	114.3 ⁰ _{-0.025} (4.50 ⁰ _{-0.0010})	180 (7.09)	3.2 (0.13)	3 (0.12)	0.5 (0.0197)	18 (0.71)	230 (9.06)	76 (2.99)	62 (2.44)	13.5 (0.53)
55ASA	200 (7.87)	114.3 ⁰ _{-0.025} (4.50 ⁰ _{-0.0010})	180 (7.09)	3.2 (0.13)	3 (0.12)	0.5 (0.0197)	18 (0.71)	230 (9.06)	76 (2.99)	62 (2.44)	13.5 (0.53)
75ASA	200 (7.87)	114.3 ⁰ _{-0.025} (4.50 ⁰ _{-0.0010})	180 (7.09)	3.2 (0.13)	3 (0.12)	0.5 (0.0197)	18 (0.71)	230 (9.06)	76 (2.99)	62 (2.44)	13.5 (0.53)
1AASA	235 (9.25)	200 ⁰ _{-0.046} (7.87 ⁰ _{-0.0018})	220 (8.66)	4 (0.16)	4 (0.16)	-	18 (0.71)	270 (10.63)	62 (2.44)	-	13.5 (0.53)
1EASA	235 (9.25)	200 ⁰ _{-0.046} (7.87 ⁰ _{-0.0018})	220 (8.66)	4 (0.16)	4 (0.16)	-	20 (0.79)	270 (10.63)	85 (3.35)	-	13.5 (0.53)

USING THE DIGITAL OPERATOR

5.4.1 Servomotor Dimensional Drawings cont.

in mm (inches)

Type SGMG-	Shaft end dimensions			Approx. mass kg (lb)
	S	S1	Q	
05ASA	$19 \begin{matrix} 0 \\ - 0.013 \\ 0 \\ (0.75 - 0.0005) \end{matrix}$	$30 \begin{matrix} (1.18) \end{matrix}$	$40 \begin{matrix} (1.57) \end{matrix}$	$5.9 \begin{matrix} (13.00) \end{matrix}$
09ASA	$19 \begin{matrix} 0 \\ - 0.013 \\ 0 \\ (0.75 - 0.0005) \end{matrix}$	$30 \begin{matrix} (1.18) \end{matrix}$	$40 \begin{matrix} (1.57) \end{matrix}$	$8.0 \begin{matrix} (17.63) \end{matrix}$
13ASA	$22 \begin{matrix} 0 \\ - 0.013 \\ 0 \\ (0.87 - 0.0005) \end{matrix}$	$30 \begin{matrix} (1.18) \end{matrix}$	$40 \begin{matrix} (1.57) \end{matrix}$	$10 \begin{matrix} (22.04) \end{matrix}$
20ASA	$35 \begin{matrix} + 0.01 \\ 0 \\ (1.38 + 0.0004) \\ 0 \end{matrix}$	$45 \begin{matrix} (1.77) \end{matrix}$	$76 \begin{matrix} (2.99) \end{matrix}$	$14 \begin{matrix} (30.86) \end{matrix}$
30ASA	$35 \begin{matrix} + 0.01 \\ 0 \\ (1.38 + 0.0004) \\ 0 \end{matrix}$	$45 \begin{matrix} (1.77) \end{matrix}$	$76 \begin{matrix} (2.99) \end{matrix}$	$18.5 \begin{matrix} (40.77) \end{matrix}$
44ASA	$35 \begin{matrix} + 0.01 \\ 0 \\ (1.38 + 0.0004) \\ 0 \end{matrix}$	$45 \begin{matrix} (1.77) \end{matrix}$	$76 \begin{matrix} (2.99) \end{matrix}$	$24 \begin{matrix} (52.90) \end{matrix}$
55ASA	$42 \begin{matrix} 0 \\ - 0.016 \\ 0 \\ (1.65 - 0.0006) \end{matrix}$	$45 \begin{matrix} (1.77) \end{matrix}$	$110 \begin{matrix} (4.33) \end{matrix}$	$30 \begin{matrix} (66.12) \end{matrix}$
75ASA	$42 \begin{matrix} 0 \\ - 0.016 \\ 0 \\ (1.65 - 0.0006) \end{matrix}$	$45 \begin{matrix} (1.77) \end{matrix}$	$110 \begin{matrix} (4.33) \end{matrix}$	$40 \begin{matrix} (88.16) \end{matrix}$
1AASA	$42 \begin{matrix} 0 \\ - 0.016 \\ 0 \\ (1.65 - 0.0006) \end{matrix}$	$45 \begin{matrix} (1.77) \end{matrix}$	$110 \begin{matrix} (4.33) \end{matrix}$	$58 \begin{matrix} (127.83) \end{matrix}$
1EASA	$55 \begin{matrix} + 0.030 \\ + 0.011 \\ (2.17 + 0.0012) \\ + 0.0004 \end{matrix}$	$65 \begin{matrix} (2.56) \end{matrix}$	$110 \begin{matrix} (4.33) \end{matrix}$	$86 \begin{matrix} (189.6) \end{matrix}$

Note 1) Absolute encoder (15bit : 8192 P/R) is used as a detector.

2) SGMG-05ASA to -44ASA do not contain eyebolts.

- Connector Wiring on Detector Side

Receptacle: MS3102A20-29P

Plug (To be prepared by customer) (L type): MS3108B20-29S or
(Straight type) MS3106B20-29S

Cable Clamp: (To be prepared by customer) MS3057-12A

Encoder Wiring Specifications

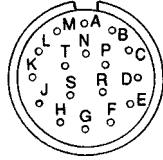

A	A channel output	K	
B	/A channel output	L	
C	B channel output	M	
D	/B channel output	N	
E	Z (C) channel output	P	
F	/Z (C) channel output	R	Reset
G	0V	S	0V
H	+5V DC	T	3.6V
J	FG (Frame Ground)		

- Note**
- 1) Terminals K to P are not used. Do not connect anything.
 - 2) Receptacle, plug and cable clamp are common regardless of motor capacity.

- Connector Wiring on Motor Side



Motor Wiring Specifications

A	Phase U
B	Phase V
C	Phase W
D	Ground terminal

- Note** Receptacle, plug and cable clamp differ depending on the capacity. Refer to 6) Connectors on Detector and Motor Sides (page 392).

Absolute encoder (15bit : 8192 P/R, 12 bit : 1024 P/R), with brake

- 0.5 to 4.4kW

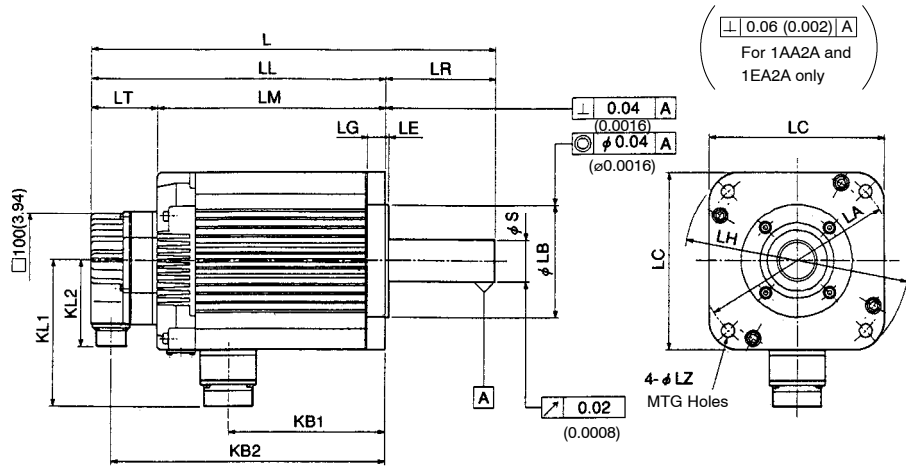

Detailed View of Shaft End for SGMG-05ASAAB to -13ASAAB

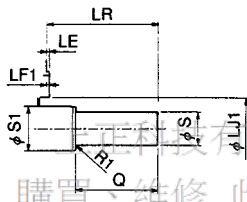

Detailed View of Shaft End for SGMG-20ASAAB to -44ASAAB

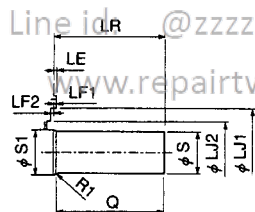

5

www.repairtw.com
 購買、維修 此手冊零組件
 電話： 037-466333
 Email: service@repairtw.com

Line id: @zzzz
 www.repairtw.com

in mm (inches)

Type SGMG-	L	LL	LM	LR	LT	KB1	KB2	KL1	KL2
05ASAAB	248 (9.76)	190 (7.48)	129 (5.08)	58 (2.28)	61 (2.40)	56 (2.20)	169 (6.65)	120 (4.72)	88 (3.46)
09ASAAB	271 (10.67)	213 (8.39)	152 (5.98)	58 (2.28)	61 (2.40)	79 (3.11)	192 (7.56)	120 (4.72)	88 (3.46)
13ASAAB	295 (11.61)	237 (9.33)	176 (6.93)	58 (2.28)	61 (2.40)	103 (4.06)	216 (8.50)	120 (4.72)	88 (3.46)
20ASAAB	310 (12.20)	231 (9.09)	170 (6.69)	79 (3.11)	61 (2.40)	79 (3.11)	210 (8.27)	146 (5.75)	88 (3.46)
30ASAAB	336 (13.23)	257 (10.12)	196 (7.72)	79 (3.11)	61 (2.40)	105 (4.13)	236 (9.29)	146 (5.75)	88 (3.46)
44ASAAB	370 (14.57)	291 (11.46)	230 (9.06)	79 (3.11)	61 (2.40)	139 (5.47)	270 (10.63)	146 (5.75)	88 (3.46)

in mm (inches)

Type SGMG-	Flange dimensions										
	LA	LB	LC	LE	LF1	LF2	LG	LH	LJ1	LJ2	LZ
05ASAAB	145 (5.71)	110 ⁰ _{-0.035} (4.33 ⁰ _{-0.0014})	130 (5.12)	6 (0.24)	6 (0.24)	-	12 (0.47)	165 (6.50)	45 (1.77)	-	9 (0.35)
09ASAAB	145 (5.71)	110 ⁰ _{-0.035} (4.33 ⁰ _{-0.0014})	130 (5.12)	6 (0.24)	6 (0.24)	-	12 (0.47)	165 (6.50)	45 (1.77)	-	9 (0.35)
13ASAAB	145 (5.71)	110 ⁰ _{-0.035} (4.33 ⁰ _{-0.0014})	130 (5.12)	6 (0.24)	6 (0.24)	-	12 (0.47)	165 (6.50)	45 (1.77)	-	9 (0.35)
20ASAAB	200 (7.87)	114.3 ⁰ _{-0.025} (4.50 ⁰ _{-0.0010})	180 (7.09)	3.2 (0.13)	3 (0.12)	0.5 (0.0197)	18 (0.71)	230 (9.06)	76 (2.99)	62 (2.44)	13.5 (0.53)
30ASAAB	200 (7.87)	114.3 ⁰ _{-0.025} (4.50 ⁰ _{-0.0010})	180 (7.09)	3.2 (0.13)	3 (0.12)	0.5 (0.0197)	18 (0.71)	230 (9.06)	76 (2.99)	62 (2.44)	13.5 (0.53)
44ASAAB	200 (7.87)	114.3 ⁰ _{-0.025} (4.50 ⁰ _{-0.0010})	180 (7.09)	3.2 (0.13)	3 (0.12)	0.5 (0.0197)	18 (0.71)	230 (9.06)	76 (2.99)	62 (2.44)	13.5 (0.53)

USING THE DIGITAL OPERATOR

5.4.1 Servomotor Dimensional Drawings cont.

in mm (inches)

Type SGMG-	Shaft end dimensions			Approx. mass kg (lb)
	S	S1	Q	
05ASAAB	$19 \begin{smallmatrix} 0 \\ - 0.013 \\ 0 \end{smallmatrix}$ (0.75 - 0.0005)	30 (1.18)	40 (1.57)	7.9 (17.41)
09ASAAB	$19 \begin{smallmatrix} 0 \\ - 0.013 \\ 0 \end{smallmatrix}$ (0.75 - 0.0005)	30 (1.18)	40 (1.57)	10 (22.04)
13ASAAB	$22 \begin{smallmatrix} 0 \\ - 0.013 \\ 0 \end{smallmatrix}$ (0.87 - 0.0005)	30 (1.18)	40 (1.57)	12 (26.45)
20ASAAB	$35 \begin{smallmatrix} + 0.01 \\ 0 \\ + 0.0004 \\ 0 \end{smallmatrix}$ (1.38)	45 (1.77)	76 (2.99)	19.5 (42.98)
30ASAAB	$35 \begin{smallmatrix} + 0.01 \\ 0 \\ + 0.0004 \\ 0 \end{smallmatrix}$ (1.38)	45 (1.77)	76 (2.99)	23.5 (51.79)
44ASAAB	$35 \begin{smallmatrix} + 0.01 \\ 0 \\ + 0.0004 \\ 0 \end{smallmatrix}$ (1.38)	45 (1.77)	76 (2.99)	29 (63.92)

5

上正科技有限公司

Note Absolute encoder (15bit : 8192 P/R) is used as a detector.

購買、維修 此子冊零件

電話: 037-466333

Email: service@repairtw.com

Motor Wiring Specifications

Line id: @zzzz

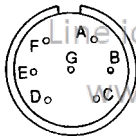

A	Phase U	E	Brake terminal
B	Phase V	F	Brake terminal
C	Phase W	G	-
D	Frame ground (FG)		

• 5.5 to 15kW

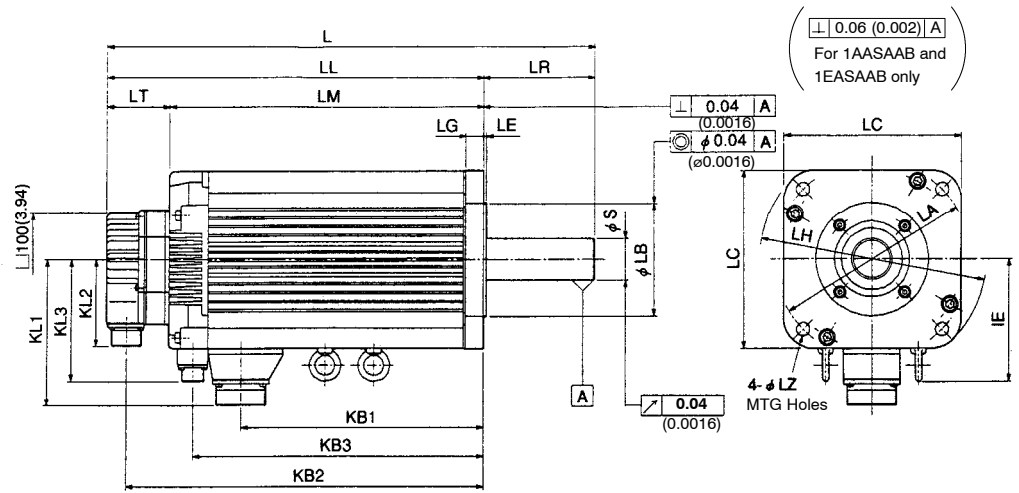

Detailed View of Shaft End for SGMG-55ASAAB and -75ASAAB

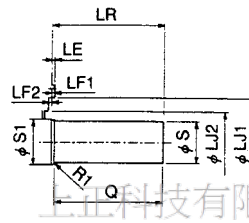

Detailed View of Shaft End for SGMG-1AASAAB and -1EASAAB

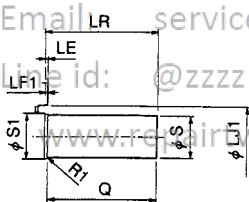

in mm (inches)

Type SGMG-	L	LL	LM	LR	LT	KB1	KB2	KB3	IE	KL1	KL2	KL3
55ASAAB	438 (17.24)	325 (12.80)	264 (10.39)	113 (4.45)	61 (2.40)	174 (6.85)	304 (11.97)	231 (9.09)	125 (4.92)	150 (5.91)	88 (3.46)	123 (4.84)
75ASAAB	512 (20.16)	399 (15.71)	338 (13.31)	113 (4.45)	61 (2.40)	248 (9.76)	378 (14.88)	305 (12.01)	125 (4.92)	150 (5.91)	88 (3.46)	123 (4.84)
1AASAAB	513 (20.20)	397 (15.63)	340 (13.39)	116 (4.57)	57 (2.24)	258 (10.16)	376 (14.80)	315 (12.40)	142 (5.59)	168 (6.61)	88 (3.46)	142 (5.59)
1EASAAB	649 (25.53)	533 (20.98)	473 (18.62)	116 (4.57)	60 (2.36)	343 (13.50)	511 (20.12)	415 (16.39)	142 (5.59)	168 (6.61)	88 (3.46)	142 (5.59)

上海正科有限公司
 購買、維修 此手冊零組件
 電話：057-466535
 Email: service@repairtw.com
 Line id: @zzzz
 www.repairtw.com

USING THE DIGITAL OPERATOR

5.4.1 Servomotor Dimensional Drawings cont.

in mm (inches)

Type SGMG-	Flange dimensions										
	LA	LB	LC	LE	LF1	LF2	LG	LH	LJ1	LJ2	LZ
55ASAAB	200 (7.87)	114.3 ⁰ _{-0.025} (4.50 ⁰ _{-0.0010})	180 (7.09)	3.2 (0.13)	3 (0.12)	0.5 (0.0197)	18 (0.71)	230 (9.06)	76 (2.99)	62 (2.44)	13.5 (0.53)
75ASAAB	200 (7.87)	114.3 ⁰ _{-0.025} (4.50 ⁰ _{-0.0010})	180 (7.09)	3.2 (0.13)	3 (0.12)	0.5 (0.0197)	18 (0.71)	230 (9.06)	76 (2.99)	62 (2.44)	13.5 (0.53)
1AASAAB	235 (9.25)	200 ⁰ _{-0.046} (7.87 ⁰ _{-0.0018})	220 (8.66)	4 (0.16)	4 (0.16)	-	18 (0.71)	270 (10.63)	62 (2.44)	-	13.5 (0.53)
1EASAAB	235 (9.25)	200 ⁰ _{-0.046} (7.87 ⁰ _{-0.0018})	220 (8.66)	4 (0.16)	4 (0.16)	-	20 (0.79)	270 (10.63)	85 (3.35)	-	13.5 (0.53)

in mm (inches)

Type SGMG-	Shaft end dimensions			Approx. mass kg (lb)
	S	S1	Q	
55ASAAB	42 ⁰ _{-0.016} (1.65 ⁰ _{-0.0006})	45 (1.77)	110 (4.33)	36 (79.34)
75ASAAB	42 ⁰ _{-0.016} (1.65 ⁰ _{-0.0006})	45 (1.77)	110 (4.33)	50 (110.20)
1AASAAB	42 ⁰ _{-0.016} (1.65 ⁰ _{-0.0006})	45 (1.77)	110 (4.33)	65.5 (144.36)
1EASAAB	55 ^{+0.030} _{+0.011} (2.17 ^{+0.0012} _{+0.0004})	65 (2.56)	110 (4.33)	100 (220.47)

Note Absolute encoder (15bit : 8192 P/R) is used as a detector.

- Connector Wiring on Brake and Motor Sides



A	Brake terminal
B	Brake terminal
C	

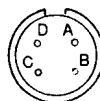

A	Phase U
B	Phase V
C	Phase W
D	Frame ground (FG)

Standard backlash gear (1500 min⁻¹), without brake

- Foot-mounted type

Grease-lubrication type servomotors

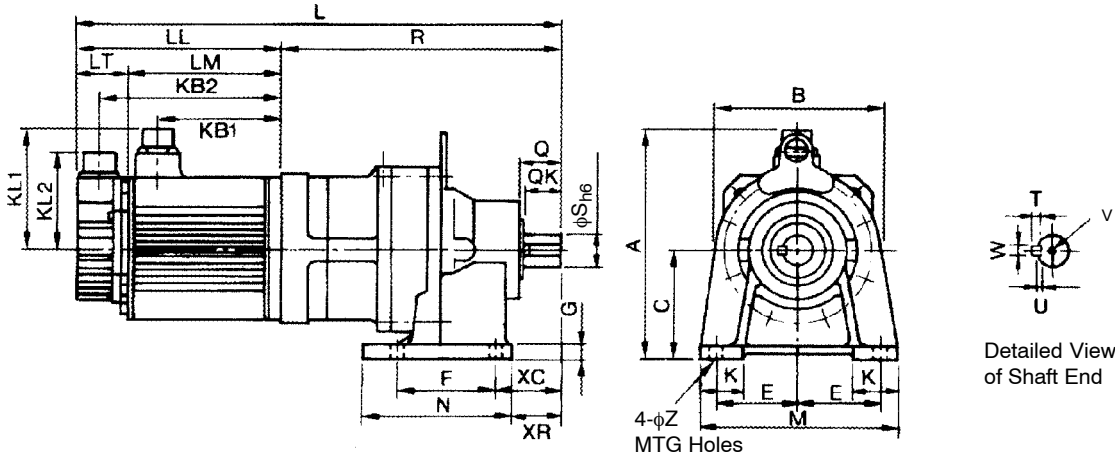

in mm (inches)

Motor type SGMG-	Gear type	Gear ratio	L	LL	LM	LT	KB1	KB2	KL1	KL2	R	A	B	C	Shaft center allowable radial load N
05A2ASAR	CNHX-4095	1/6	380 (15.0)	138 (5.43)	92 (3.62)	46 (1.81)	65 (2.56)	117 (4.61)	109 (4.29)	88 (3.46)	242 (9.53)	209 (8.23)	152 (5.98)	100 ⁰ _{-0.5} (3.94 ⁰ _{-0.020})	2050
05A2ASBR	CNHX-4095	1/11	380 (15.0)	138 (5.43)	92 (3.62)	46 (1.81)	65 (2.56)	117 (4.61)	109 (4.29)	88 (3.46)	242 (9.53)	209 (8.23)	152 (5.98)	100 ⁰ _{-0.5} (3.94 ⁰ _{-0.020})	2520
05A2ASCR	CNHX-4105	1/21	394 (15.5)	138 (5.43)	92 (3.62)	46 (1.81)	65 (2.56)	117 (4.61)	109 (4.29)	88 (3.46)	256 (10.1)	209 (8.23)	152 (5.98)	100 ⁰ _{-0.5} (3.94 ⁰ _{-0.020})	4940
05A2AS7R	CNHX-4105	1/29	394 (15.5)	138 (5.43)	92 (3.62)	46 (1.81)	65 (2.56)	117 (4.61)	109 (4.29)	88 (3.46)	256 (10.1)	209 (8.23)	152 (5.98)	100 ⁰ _{-0.5} (3.94 ⁰ _{-0.020})	5360
09A2ASAR	CNHX-4105	1/6	417 (16.4)	161 (6.34)	115 (4.53)	46 (1.81)	88 (3.46)	140 (5.51)	109 (4.29)	88 (3.46)	256 (10.1)	209 (8.23)	152 (5.98)	100 ⁰ _{-0.5} (3.94 ⁰ _{-0.020})	3240
09A2ASBR	CNHX-4105	1/11	417 (16.4)	161 (6.34)	115 (4.53)	46 (1.81)	88 (3.46)	140 (5.51)	109 (4.29)	88 (3.46)	256 (10.1)	209 (8.23)	152 (5.98)	100 ⁰ _{-0.5} (3.94 ⁰ _{-0.020})	3840
09A2ASCR	CNHX-4115	1/21	449 (17.7)	161 (6.34)	115 (4.53)	46 (1.81)	88 (3.46)	140 (5.51)	109 (4.29)	88 (3.46)	288 (11.3)	257 (10.1)	204 (8.03)	120 ⁰ _{-0.5} (4.72 ⁰ _{-0.020})	6190
09A2AS7R	CNHX-4115	1/29	449 (17.7)	161 (6.34)	115 (4.53)	46 (1.81)	88 (3.46)	140 (5.51)	109 (4.29)	88 (3.46)	288 (11.3)	257 (10.1)	204 (8.03)	120 ⁰ _{-0.5} (4.72 ⁰ _{-0.020})	6870
13A2ASAR	CNHX-4105	1/6	441 (17.4)	185 (7.28)	139 (5.47)	46 (1.81)	112 (4.41)	164 (6.46)	109 (4.29)	88 (3.46)	256 (10.1)	209 (8.23)	152 (5.98)	100 ⁰ _{-0.5} (3.94 ⁰ _{-0.020})	3240
13A2ASBR	CNHX-4115	1/11	473 (18.6)	185 (7.28)	139 (5.47)	46 (1.81)	112 (4.41)	164 (6.46)	109 (4.29)	88 (3.46)	288 (11.3)	257 (10.1)	204 (8.03)	120 ⁰ _{-0.5} (4.72 ⁰ _{-0.020})	4970
13A2ASCR	CNHX-4115	1/21	473 (18.6)	185 (7.28)	139 (5.47)	46 (1.81)	112 (4.41)	164 (6.46)	109 (4.29)	88 (3.46)	288 (11.3)	257 (10.1)	204 (8.03)	120 ⁰ _{-0.5} (4.72 ⁰ _{-0.020})	6190

USING THE DIGITAL OPERATOR

5.4.1 Servomotor Dimensional Drawings cont.

Motor type SGMG-	Gear type	Gear ratio	L	LL	LM	LT	KB1	KB2	KL1	KL2	R	A	B	C	Shaft center allowable radial load N
13A2AS7R	CHHX-4135	1/29	532 (20.9)	185 (7.28)	139 (5.47)	46 (1.81)	112 (4.41)	164 (6.46)	109 (4.29)	88 (3.46)	347 (13.7)	300 (11.8)	246 (9.69)	150 ⁰ _{-0.5} (5.91 ⁰ _{-0.020})	9900
20A2ASAR	CNHX-4115	1/6	477 (18.8)	166 (6.54)	119 (4.69)	47 (1.85)	89 (3.50)	145 (5.71)	140 (5.51)	88 (3.46)	311 (12.2)	260 (10.2)	204 (8.03)	120 ⁰ _{-0.5} (4.72 ⁰ _{-0.020})	4050
20A2ASBR	CNHX-4115	1/11	477 (18.8)	166 (6.54)	119 (4.69)	47 (1.85)	89 (3.50)	145 (5.71)	140 (5.51)	88 (3.46)	311 (12.2)	260 (10.2)	204 (8.03)	120 ⁰ _{-0.5} (4.72 ⁰ _{-0.020})	4970
20A2ASCR	CHHX-4130	1/21	536 (21.1)	166 (6.54)	119 (4.69)	47 (1.85)	89 (3.50)	145 (5.71)	140 (5.51)	88 (3.46)	370 (14.6)	300 (11.8)	246 (9.69)	150 ⁰ _{-0.5} (5.91 ⁰ _{-0.020})	8940
20A2AS7R	CHHX-4135	1/29	536 (21.1)	166 (6.54)	119 (4.69)	47 (1.85)	89 (3.50)	145 (5.71)	140 (5.51)	88 (3.46)	370 (14.6)	300 (11.8)	246 (9.69)	150 ⁰ _{-0.5} (5.91 ⁰ _{-0.020})	9900
30A2ASAR	CNHX-4115	1/6	503 (19.8)	192 (7.56)	145 (5.71)	47 (1.85)	115 (4.53)	171 (6.73)	140 (5.51)	88 (3.46)	311 (12.2)	260 (10.2)	204 (8.03)	120 ⁰ _{-0.5} (4.72 ⁰ _{-0.020})	4050
30A2ASBR	CNHX-4115	1/11	503 (19.8)	192 (7.56)	145 (5.71)	47 (1.85)	115 (4.53)	171 (6.73)	140 (5.51)	88 (3.46)	311 (12.2)	260 (10.2)	204 (8.03)	120 ⁰ _{-0.5} (4.72 ⁰ _{-0.020})	4970
30A2ASCR	CHHX-4145	1/21	582 (22.9)	192 (7.56)	145 (5.71)	47 (1.85)	115 (4.53)	171 (6.73)	140 (5.51)	88 (3.46)	390 (15.4)	300 (11.8)	246 (9.69)	150 ⁰ _{-0.5} (5.91 ⁰ _{-0.020})	11590
44A2ASAR	CHHX-4130	1/6	596 (23.5)	226 (8.90)	179 (7.05)	47 (1.85)	149 (5.87)	205 (8.07)	140 (5.51)	88 (3.46)	370 (14.6)	300 (11.8)	246 (9.69)	150 ⁰ _{-0.5} (5.91 ⁰ _{-0.020})	5870
44A2ASBR	CHHX-4135	1/11	596 (23.5)	226 (8.90)	179 (7.05)	47 (1.85)	149 (5.87)	205 (8.07)	140 (5.51)	88 (3.46)	370 (14.6)	300 (11.8)	246 (9.69)	150 ⁰ _{-0.5} (5.91 ⁰ _{-0.020})	7190
55A2ASAR	CHHX-4135	1/6	664 (26.1)	260 (10.2)	213 (8.39)	47 (1.85)	174 (6.85)	239 (9.41)	150 (5.91)	88 (3.46)	404 (15.9)	300 (11.8)	246 (9.69)	150 ⁰ _{-0.5} (5.91 ⁰ _{-0.020})	5870
55A2ASBR	CHHX-4145	1/11	684 (26.9)	260 (10.2)	213 (8.39)	47 (1.85)	174 (6.85)	239 (9.41)	150 (5.91)	88 (3.46)	424 (16.7)	300 (11.8)	246 (9.69)	150 ⁰ _{-0.5} (5.91 ⁰ _{-0.020})	9500

5

Email: service@repairtw.com

Line id: @zzzz

in mm (inches)

Motor type SGMG-	Foot dimensions										Shaft end dimensions					Approx. mass kg (lb)	
	E	F	G	K	M	N	XR	XC	Z	Q	QK	S	T	U	W		V
05A2ASAR	75 (2.95)	90 (3.54)	12 (0.47)	40 (1.57)	180 (7.09)	130 (5.12)	45 (1.77)	60 (2.36)	11 (0.43)	35 (1.38)	32 (1.26)	φ28 ⁰ _{-0.013} (φ1.10 ⁰ _{-0.0005})	7 (0.28)	4 (0.16)	8 (0.31)	M8 screw, depth 19	20.5 (45.2)
05A2ASBR	75 (2.95)	90 (3.54)	12 (0.47)	40 (1.57)	180 (7.09)	130 (5.12)	45 (1.77)	60 (2.36)	11 (0.43)	35 (1.38)	32 (1.26)	φ28 ⁰ _{-0.013} (φ1.10 ⁰ _{-0.0005})	7 (0.28)	4 (0.16)	8 (0.31)	M8 screw, depth 19	20.5 (45.2)
05A2ASCR	75 (2.95)	90 (3.54)	12 (0.47)	40 (1.57)	180 (7.09)	135 (5.31)	45 (1.77)	60 (2.36)	11 (0.43)	35 (1.38)	32 (1.26)	φ28 ⁰ _{-0.013} (φ1.10 ⁰ _{-0.0005})	7 (0.28)	4 (0.16)	8 (0.31)	M8 screw, depth 19	22.5 (49.6)
05A2AS7R	75 (2.95)	90 (3.54)	12 (0.47)	40 (1.57)	180 (7.09)	135 (5.31)	45 (1.77)	60 (2.36)	11 (0.43)	35 (1.38)	32 (1.26)	φ28 ⁰ _{-0.013} (φ1.10 ⁰ _{-0.0005})	7 (0.28)	4 (0.16)	8 (0.31)	M8 screw, depth 19	22.5 (49.6)
09A2ASAR	75 (2.95)	90 (3.54)	12 (0.47)	40 (1.57)	180 (7.09)	135 (5.31)	45 (1.77)	60 (2.36)	11 (0.43)	35 (1.38)	32 (1.26)	φ28 ⁰ _{-0.013} (φ1.10 ⁰ _{-0.0005})	7 (0.28)	4 (0.16)	8 (0.31)	M8 screw, depth 19	24.6 (54.2)

Motor type SGMG-	Foot dimensions									Shaft end dimensions						Approx. mass kg (lb)	
	E	F	G	K	M	N	XR	XC	Z	Q	QK	S	T	U	W		V
09A2ASBR	75 (2.95)	90 (3.54)	12 (0.47)	40 (1.57)	180 (7.09)	135 (5.31)	45 (1.77)	60 (2.36)	11 (0.43)	35 (1.38)	32 (1.26)	$\phi 28 \begin{smallmatrix} 0 \\ -0.013 \\ 0 \end{smallmatrix}$ $(\phi 1.10 \begin{smallmatrix} 0 \\ -0.0005 \end{smallmatrix})$	7 (0.28)	4 (0.16)	8 (0.31)	M8 screw, depth 19	24.6 (54.2)
09A2ASCR	95 (3.74)	115 (4.53)	15 (0.59)	55 (2.17)	230 (9.06)	155 (6.10)	62 (2.44)	82 (3.23)	14 (0.55)	55 (2.17)	50 (1.97)	$\phi 38 \begin{smallmatrix} 0 \\ -0.016 \\ 0 \end{smallmatrix}$ $(\phi 1.50 \begin{smallmatrix} 0 \\ -0.0006 \end{smallmatrix})$	8 (0.31)	5 (0.20)	10 (0.39)	M10 screw, depth 22	34.6 (76.3)
09A2AS7R	95 (3.74)	115 (4.53)	15 (0.59)	55 (2.17)	230 (9.06)	155 (6.10)	62 (2.44)	82 (3.23)	14 (0.55)	55 (2.17)	50 (1.97)	$\phi 38 \begin{smallmatrix} 0 \\ -0.016 \\ 0 \end{smallmatrix}$ $(\phi 1.50 \begin{smallmatrix} 0 \\ -0.0006 \end{smallmatrix})$	8 (0.31)	5 (0.20)	10 (0.39)	M10 screw, depth 22	34.6 (76.3)
13A2ASAR	75 (2.95)	90 (3.54)	12 (0.47)	40 (1.57)	180 (7.09)	135 (5.31)	45 (1.77)	60 (2.36)	11 (0.43)	35 (1.38)	32 (1.26)	$\phi 28 \begin{smallmatrix} 0 \\ -0.013 \\ 0 \end{smallmatrix}$ $(\phi 1.10 \begin{smallmatrix} 0 \\ -0.0005 \end{smallmatrix})$	7 (0.28)	4 (0.16)	8 (0.31)	M8 screw, depth 19	26.6 (58.7)
13A2ASBR	95 (3.74)	115 (4.53)	15 (0.59)	55 (2.17)	230 (9.06)	155 (6.10)	62 (2.44)	82 (3.23)	14 (0.55)	55 (2.17)	50 (1.97)	$\phi 38 \begin{smallmatrix} 0 \\ -0.016 \\ 0 \end{smallmatrix}$ $(\phi 1.50 \begin{smallmatrix} 0 \\ -0.0006 \end{smallmatrix})$	8 (0.31)	5 (0.20)	10 (0.39)	M10 screw, depth 22	36.6 (80.7)
13A2ASCR	95 (3.74)	115 (4.53)	15 (0.59)	55 (2.17)	230 (9.06)	155 (6.10)	62 (2.44)	82 (3.23)	14 (0.55)	55 (2.17)	50 (1.97)	$\phi 38 \begin{smallmatrix} 0 \\ -0.016 \\ 0 \end{smallmatrix}$ $(\phi 1.50 \begin{smallmatrix} 0 \\ -0.0006 \end{smallmatrix})$	8 (0.31)	5 (0.20)	10 (0.39)	M10 screw, depth 22	36.6 (80.7)
13A2AS7R	145 (5.71)	145 (5.71)	22 (0.87)	65 (2.56)	330 (13.0)	195 (7.68)	75 (2.95)	100 (3.94)	18 (0.71)	70 (2.76)	56 (2.20)	$\phi 50 \begin{smallmatrix} 0 \\ -0.016 \\ 0 \end{smallmatrix}$ $(\phi 1.97 \begin{smallmatrix} 0 \\ -0.0006 \end{smallmatrix})$	9 (0.35)	5.5 (0.22)	14 (0.55)	M10 screw, depth 18	57.6 (127.0)
20A2ASAR	95 (3.74)	115 (4.53)	15 (0.59)	55 (2.17)	230 (9.06)	155 (6.10)	62 (2.44)	82 (3.23)	14 (0.55)	55 (2.17)	50 (1.97)	$\phi 38 \begin{smallmatrix} 0 \\ -0.016 \\ 0 \end{smallmatrix}$ $(\phi 1.50 \begin{smallmatrix} 0 \\ -0.0006 \end{smallmatrix})$	8 (0.31)	5 (0.20)	10 (0.39)	M10 screw, depth 22	43 (94.8)
20A2ASBR	95 (3.74)	115 (4.53)	15 (0.59)	55 (2.17)	230 (9.06)	155 (6.10)	62 (2.44)	82 (3.23)	14 (0.55)	55 (2.17)	50 (1.97)	$\phi 38 \begin{smallmatrix} 0 \\ -0.016 \\ 0 \end{smallmatrix}$ $(\phi 1.50 \begin{smallmatrix} 0 \\ -0.0006 \end{smallmatrix})$	8 (0.31)	5 (0.20)	10 (0.39)	M10 screw, depth 22	43 (94.8)
20A2ASCR	145 (5.71)	145 (5.71)	22 (0.87)	65 (2.56)	330 (13.0)	195 (7.68)	95 (3.74)	100 (3.94)	18 (0.71)	70 (2.76)	56 (2.20)	$\phi 50 \begin{smallmatrix} 0 \\ -0.016 \\ 0 \end{smallmatrix}$ $(\phi 1.97 \begin{smallmatrix} 0 \\ -0.0006 \end{smallmatrix})$	9 (0.35)	5.5 (0.22)	14 (0.55)	M10 screw, depth 18	67 (147.7)
20A2AS7R	145 (5.71)	145 (5.71)	22 (0.87)	65 (2.56)	330 (13.0)	195 (7.68)	75 (2.95)	100 (3.94)	18 (0.71)	70 (2.76)	56 (2.20)	$\phi 50 \begin{smallmatrix} 0 \\ -0.016 \\ 0 \end{smallmatrix}$ $(\phi 1.97 \begin{smallmatrix} 0 \\ -0.0006 \end{smallmatrix})$	9 (0.35)	5.5 (0.22)	14 (0.55)	M10 screw, depth 18	67 (147.7)
30A2ASAR	95 (3.74)	115 (4.53)	15 (0.59)	55 (2.17)	230 (9.06)	155 (6.10)	62 (2.44)	82 (3.23)	14 (0.55)	55 (2.17)	50 (1.97)	$\phi 38 \begin{smallmatrix} 0 \\ -0.016 \\ 0 \end{smallmatrix}$ $(\phi 1.50 \begin{smallmatrix} 0 \\ -0.0006 \end{smallmatrix})$	8 (0.31)	5 (0.20)	10 (0.39)	M10 screw, depth 22	47 (103.6)
30A2ASBR	95 (3.74)	115 (4.53)	15 (0.59)	55 (2.17)	230 (9.06)	155 (6.10)	62 (2.44)	82 (3.23)	14 (0.55)	55 (2.17)	50 (1.97)	$\phi 38 \begin{smallmatrix} 0 \\ -0.016 \\ 0 \end{smallmatrix}$ $(\phi 1.50 \begin{smallmatrix} 0 \\ -0.0006 \end{smallmatrix})$	8 (0.31)	5 (0.20)	10 (0.39)	M10 screw, depth 22	47 (103.6)
30A2ASCR	145 (5.71)	145 (5.71)	22 (0.87)	65 (2.56)	330 (13.0)	195 (7.68)	95 (3.74)	120 (4.72)	18 (0.71)	90 (3.54)	80 (3.15)	$\phi 50 \begin{smallmatrix} 0 \\ -0.016 \\ 0 \end{smallmatrix}$ $(\phi 1.97 \begin{smallmatrix} 0 \\ -0.0006 \end{smallmatrix})$	9 (0.35)	5.5 (0.22)	14 (0.55)	M10 screw, depth 18	72 (158.7)
44A2ASAR	145 (5.71)	145 (5.71)	22 (0.87)	65 (2.56)	330 (13.0)	195 (7.68)	75 (2.95)	100 (3.94)	18 (0.71)	70 (2.76)	56 (2.20)	$\phi 50 \begin{smallmatrix} 0 \\ -0.016 \\ 0 \end{smallmatrix}$ $(\phi 1.97 \begin{smallmatrix} 0 \\ -0.0006 \end{smallmatrix})$	9 (0.35)	5.5 (0.22)	14 (0.55)	M10 screw, depth 18	76 (167.5)
44A2ASBR	145 (5.71)	145 (5.71)	22 (0.87)	65 (2.56)	330 (13.0)	195 (7.68)	75 (2.95)	100 (3.94)	18 (0.71)	70 (2.76)	56 (2.20)	$\phi 50 \begin{smallmatrix} 0 \\ -0.016 \\ 0 \end{smallmatrix}$ $(\phi 1.97 \begin{smallmatrix} 0 \\ -0.0006 \end{smallmatrix})$	9 (0.35)	5.5 (0.22)	14 (0.55)	M10 screw, depth 18	76 (167.5)
55A2ASAR	145 (5.71)	145 (5.71)	22 (0.87)	65 (2.56)	330 (13.0)	195 (7.68)	75 (2.95)	100 (3.94)	18 (0.71)	70 (2.76)	56 (2.20)	$\phi 50 \begin{smallmatrix} 0 \\ -0.016 \\ 0 \end{smallmatrix}$ $(\phi 1.97 \begin{smallmatrix} 0 \\ -0.0006 \end{smallmatrix})$	9 (0.35)	5.5 (0.22)	14 (0.55)	M10 screw, depth 18	88 (194.0)
55A2ASBR	145 (5.71)	145 (5.71)	22 (0.87)	65 (2.56)	330 (13.0)	195 (7.68)	95 (3.74)	120 (4.72)	18 (0.71)	90 (3.54)	80 (3.15)	$\phi 50 \begin{smallmatrix} 0 \\ -0.016 \\ 0 \end{smallmatrix}$ $(\phi 1.97 \begin{smallmatrix} 0 \\ -0.0006 \end{smallmatrix})$	9 (0.35)	5.5 (0.22)	14 (0.55)	M10 screw, depth 18	89 (196.2)

Oil-lubrication type servomotors

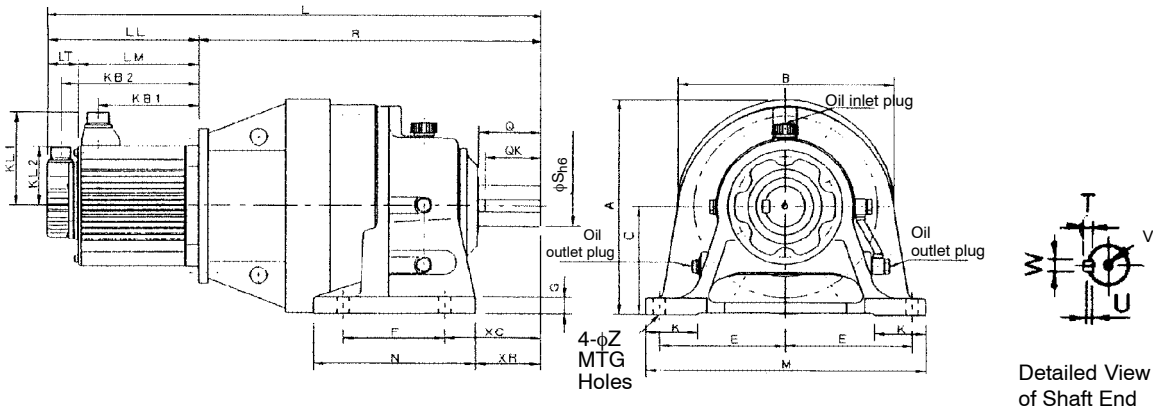

in mm (inches)

Motor type SGMG-	Gear type	Gear ratio	L	LL	LM	LT	KB1	KB2	KL1	KL2	R	A	B	C	Shaft center allowable radial load N
30A2AS7R	CHHJ-4160	1/29	687 (27.1)	192 (7.56)	145 (5.71)	47 (1.85)	115 (4.53)	171 (6.73)	140 (5.51)	88 (3.46)	495 (19.5)	319 (12.6)	318 (12.5)	160 ⁰ _{-0.5} (6.30 ⁰ _{-0.020})	16290
44A2ASCR	CHHJ-4160	1/21	721 (28.4)	226 (8.90)	179 (7.05)	47 (1.85)	149 (5.87)	205 (8.07)	140 (5.51)	88 (3.46)	495 (19.5)	319 (12.6)	318 (12.5)	160 ⁰ _{-0.5} (6.30 ⁰ _{-0.020})	14640
44A2AS7R	CHHJ-4170	1/29	785 (30.9)	226 (8.90)	179 (7.05)	47 (1.85)	149 (5.87)	205 (8.07)	140 (5.51)	88 (3.46)	559 (22.0)	382 (15.0)	363 (14.3)	200 ⁰ _{-0.5} (7.87 ⁰ _{-0.020})	19020
55A2ASCR	CHHJ-4170	1/21	853 (33.6)	260 (10.2)	213 (8.39)	47 (1.85)	174 (6.85)	239 (9.41)	150 (5.91)	88 (3.46)	593 (23.4)	382 (15.0)	363 (14.3)	200 ⁰ _{-0.5} (7.87 ⁰ _{-0.020})	17180
55A2AS7R	CHHJ-4175	1/29	853 (33.6)	260 (10.2)	213 (8.39)	47 (1.85)	174 (6.85)	239 (9.41)	150 (5.91)	88 (3.46)	593 (23.4)	382 (15.0)	363 (14.3)	200 ⁰ _{-0.5} (7.87 ⁰ _{-0.020})	19020
75A2ASBR	CHHJ-4160	1/11	863 (34.0)	334 (13.2)	287 (11.3)	47 (1.85)	248 (9.76)	313 (12.3)	150 (5.91)	88 (3.46)	529 (20.8)	319 (12.6)	318 (12.5)	160 ⁰ _{-0.5} (6.30 ⁰ _{-0.020})	11740
75A2ASCR	CHHJ-4175	1/21	927 (36.5)	334 (13.2)	287 (11.3)	47 (1.85)	248 (9.76)	313 (12.3)	150 (5.91)	88 (3.46)	593 (23.4)	381 (15.0)	363 (14.3)	200 ⁰ _{-0.5} (7.87 ⁰ _{-0.020})	17180
75A2AS7R	CHHJ-4180	1/29	977 (38.5)	334 (13.2)	287 (11.3)	47 (1.85)	248 (9.76)	313 (12.3)	150 (5.91)	88 (3.46)	643 (25.3)	417 (16.4)	392 (15.4)	220 ⁰ _{-0.5} (8.66 ⁰ _{-0.020})	25600
1AA2ASBR	CHHJ-4170	1/11	934 (36.8)	338 (13.3)	291 (11.5)	47 (1.85)	251 (9.88)	317 (12.5)	168 (6.61)	88 (3.46)	596 (23.5)	382 (15.0)	363 (14.3)	200 ⁰ _{-0.5} (7.87 ⁰ _{-0.020})	13800
1AA2ASCR	CHHJ-4185	1/21	984 (38.7)	338 (13.3)	291 (11.5)	47 (1.85)	251 (9.88)	317 (12.5)	168 (6.61)	88 (3.46)	646 (25.4)	417 (16.4)	392 (15.4)	220 ⁰ _{-0.5} (8.66 ⁰ _{-0.020})	23010
1AA2AS7R	CHHJ-4190	1/29	1077 (42.4)	338 (13.3)	291 (11.5)	47 (1.85)	251 (9.88)	317 (12.5)	168 (6.61)	88 (3.46)	739 (29.1)	477 (18.8)	454 (17.9)	250 ⁰ _{-0.5} (9.84 ⁰ _{-0.020})	35810

in mm (inches)

Motor type SGMG-	Foot dimensions									Shaft end dimensions						Approx. mass kg (lb)	
	E	F	G	K	M	N	XR	XC	Z	Q	QK	S	T	U	W		V
30A2AS7R	185 (7.28)	150 (5.91)	25 (0.98)	75 (2.95)	410 (16.1)	238 (9.37)	95 (3.74)	139 (5.47)	18 (0.71)	90 (3.54)	80 (3.15)	$\phi 60 \begin{smallmatrix} 0 \\ -0.019 \\ 0 \\ -0.0007 \end{smallmatrix}$ ($\phi 2.36 \begin{smallmatrix} 0 \\ -0.0007 \end{smallmatrix}$)	11 (0.43)	7 (0.28)	18 (0.71)	M10 screw, depth 18	126 (277.8)
44A2ASCR	185 (7.28)	150 (5.91)	25 (0.98)	75 (2.95)	410 (16.1)	238 (9.37)	95 (3.74)	139 (5.47)	18 (0.71)	90 (3.54)	80 (3.15)	$\phi 60 \begin{smallmatrix} 0 \\ -0.019 \\ 0 \\ -0.0007 \end{smallmatrix}$ ($\phi 2.36 \begin{smallmatrix} 0 \\ -0.0007 \end{smallmatrix}$)	11 (0.43)	7 (0.28)	18 (0.71)	M10 screw, depth 18	131 (288.8)
44A2AS7R	190 (7.48)	275 (10.8)	30 (1.18)	80 (3.15)	430 (16.9)	335 (13.2)	95 (3.74)	125 (4.92)	22 (0.87)	90 (3.54)	80 (3.15)	$\phi 70 \begin{smallmatrix} 0 \\ -0.016 \\ 0 \\ -0.0006 \end{smallmatrix}$ ($\phi 2.76 \begin{smallmatrix} 0 \\ -0.0006 \end{smallmatrix}$)	12 (0.47)	7.5 (0.30)	20 (0.79)	M12 screw, depth 24	176 (388.0)
55A2ASCR	190 (7.48)	275 (10.8)	30 (1.18)	80 (3.15)	430 (16.9)	335 (13.2)	95 (3.74)	125 (4.92)	22 (0.87)	90 (3.54)	80 (3.15)	$\phi 70 \begin{smallmatrix} 0 \\ -0.016 \\ 0 \\ -0.0006 \end{smallmatrix}$ ($\phi 2.76 \begin{smallmatrix} 0 \\ -0.0006 \end{smallmatrix}$)	12 (0.47)	7.5 (0.30)	20 (0.79)	M12 screw, depth 24	191 (421.1)
55A2AS7R	190 (7.48)	275 (10.8)	30 (1.18)	80 (3.15)	430 (16.9)	335 (13.2)	95 (3.74)	125 (4.92)	22 (0.87)	90 (3.54)	80 (3.15)	$\phi 70 \begin{smallmatrix} 0 \\ -0.016 \\ 0 \\ -0.0006 \end{smallmatrix}$ ($\phi 2.76 \begin{smallmatrix} 0 \\ -0.0006 \end{smallmatrix}$)	12 (0.47)	7.5 (0.30)	20 (0.79)	M12 screw, depth 24	191 (421.1)
75A2ASBR	185 (7.28)	150 (5.91)	25 (0.98)	75 (2.95)	410 (16.1)	238 (9.37)	95 (3.74)	139 (5.47)	18 (0.71)	90 (3.54)	80 (3.15)	$\phi 60 \begin{smallmatrix} 0 \\ -0.019 \\ 0 \\ -0.0007 \end{smallmatrix}$ ($\phi 2.36 \begin{smallmatrix} 0 \\ -0.0007 \end{smallmatrix}$)	11 (0.43)	7 (0.28)	18 (0.71)	M10 screw, depth 18	155 (341.7)
75A2ASCR	190 (7.48)	275 (10.8)	30 (1.18)	80 (3.15)	430 (16.9)	335 (13.2)	95 (3.74)	125 (4.92)	22 (0.87)	90 (3.54)	80 (3.15)	$\phi 70 \begin{smallmatrix} 0 \\ -0.016 \\ 0 \\ -0.0006 \end{smallmatrix}$ ($\phi 2.76 \begin{smallmatrix} 0 \\ -0.0006 \end{smallmatrix}$)	12 (0.47)	7.5 (0.30)	20 (0.79)	M12 screw, depth 24	201 (443.1)
75A2AS7R	210 (8.27)	320 (12.6)	30 (1.18)	85 (3.35)	470 (18.5)	380 (15.0)	115 (4.53)	145 (5.71)	22 (0.87)	110 (4.33)	100 (3.94)	$\phi 80 \begin{smallmatrix} 0 \\ -0.016 \\ 0 \\ -0.0006 \end{smallmatrix}$ ($\phi 3.15 \begin{smallmatrix} 0 \\ -0.0006 \end{smallmatrix}$)	14 (0.55)	9 (0.35)	22 (0.87)	M12 screw, depth 24	245 (540.1)
1AA2ASBR	190 (7.48)	275 (10.8)	30 (1.18)	80 (3.15)	430 (16.9)	335 (13.2)	95 (3.74)	125 (4.92)	22 (0.87)	90 (3.54)	80 (3.15)	$\phi 70 \begin{smallmatrix} 0 \\ -0.016 \\ 0 \\ -0.0006 \end{smallmatrix}$ ($\phi 2.76 \begin{smallmatrix} 0 \\ -0.0006 \end{smallmatrix}$)	12 (0.47)	7.5 (0.30)	20 (0.79)	M12 screw, depth 24	230.5 (508.2)
1AA2ASCR	210 (8.27)	320 (12.6)	30 (1.18)	85 (3.35)	470 (18.5)	380 (15.0)	115 (4.53)	145 (5.71)	22 (0.87)	110 (4.33)	100 (3.94)	$\phi 80 \begin{smallmatrix} 0 \\ -0.016 \\ 0 \\ -0.0006 \end{smallmatrix}$ ($\phi 3.15 \begin{smallmatrix} 0 \\ -0.0006 \end{smallmatrix}$)	14 (0.55)	9 (0.35)	22 (0.87)	M12 screw, depth 24	276.5 (609.6)
1AA2AS7R	240 (9.45)	380 (15.0)	35 (1.38)	90 (3.54)	530 (20.9)	440 (17.3)	140 (5.51)	170 (6.69)	26 (1.02)	135 (5.31)	125 (4.92)	$\phi 95 \begin{smallmatrix} 0 \\ -0.022 \\ 0 \\ -0.0009 \end{smallmatrix}$ ($\phi 3.74 \begin{smallmatrix} 0 \\ -0.0009 \end{smallmatrix}$)	14 (0.55)	9 (0.35)	25 (0.98)	M20 screw, depth 34	357.5 (788.1)

Email: service@repairtw.com

Line id: @zzzz

www.repairtw.com

• Flange-mounted type
Grease-lubrication type servomotors

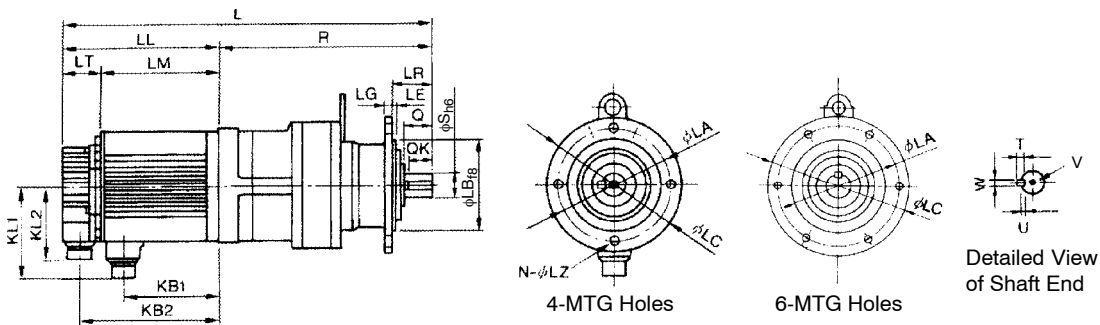

in mm (inches)

Motor type SGMG-	Gear type	Gear ratio	L	LL	LM	LT	KB1	KB2	KL1	KL2	R	A	Axis center allowable radial load N	Approx. mass kg (lb)
05A2ATAR	CNVX-4095	1/6	380 (15.0)	138 (5.43)	92 (3.62)	46 (1.81)	65 (2.56)	117 (4.61)	109 (4.29)	88 (3.46)	242 (9.53)	-	2050	18.5 (40.8)
05A2ATBR	CNVX-4095	1/11	380 (15.0)	138 (5.43)	92 (3.62)	46 (1.81)	65 (2.56)	117 (4.61)	109 (4.29)	88 (3.46)	242 (9.53)	-	2520	18.5 (40.8)
05A2ATCR	CNVX-4105	1/21	394 (15.5)	138 (5.43)	92 (3.62)	46 (1.81)	65 (2.56)	117 (4.61)	109 (4.29)	88 (3.46)	256 (10.1)	-	4940	20.5 (45.2)
05A2AT7R	CNVX-4105	1/29	394 (15.5)	138 (5.43)	92 (3.62)	46 (1.81)	65 (2.56)	117 (4.61)	109 (4.29)	88 (3.46)	256 (10.1)	-	5360	20.5 (45.2)
09A2ATAR	CNVX-4105	1/6	417 (16.4)	161 (6.34)	115 (4.53)	46 (1.81)	88 (3.46)	140 (5.51)	109 (4.29)	88 (3.46)	256 (10.1)	-	3240	22.6 (49.8)
09A2ATBR	CNVX-4105	1/11	417 (16.4)	161 (6.34)	115 (4.53)	46 (1.81)	88 (3.46)	140 (5.51)	109 (4.29)	88 (3.46)	256 (10.1)	-	3840	22.6 (49.8)
09A2ATCR	CNVX-4115	1/21	449 (17.7)	161 (6.34)	115 (4.53)	46 (1.81)	88 (3.46)	140 (5.51)	109 (4.29)	88 (3.46)	288 (11.3)	-	6190	33.6 (74.1)
09A2AT7R	CNVX-4115	1/29	449 (17.7)	161 (6.34)	115 (4.53)	46 (1.81)	88 (3.46)	140 (5.51)	109 (4.29)	88 (3.46)	288 (11.3)	-	6870	33.6 (74.1)
13A2ATAR	CNVX-4105	1/6	441 (17.4)	185 (7.28)	139 (5.47)	46 (1.81)	112 (4.41)	164 (6.46)	109 (4.29)	88 (3.46)	256 (10.1)	-	3240	24.6 (54.2)
13A2ATBR	CNVX-4115	1/11	473 (18.6)	185 (7.28)	139 (5.47)	46 (1.81)	112 (4.41)	164 (6.46)	109 (4.29)	88 (3.46)	288 (11.3)	-	4970	35.6 (78.5)
13A2ATCR	CNVX-4115	1/21	473 (18.6)	185 (7.28)	139 (5.47)	46 (1.81)	112 (4.41)	164 (6.46)	109 (4.29)	88 (3.46)	288 (11.3)	-	6190	35.6 (78.5)
20A2ATAR	CNVX-4115	1/6	477 (18.8)	166 (6.54)	119 (4.69)	47 (1.85)	89 (3.50)	145 (5.71)	140 (5.51)	88 (3.46)	311 (12.2)	-	4050	42 (92.6)
20A2ATBR	CNVX-4115	1/11	477 (18.8)	166 (6.54)	119 (4.69)	47 (1.85)	89 (3.50)	145 (5.71)	140 (5.51)	88 (3.46)	311 (12.2)	-	4970	42 (92.6)
30A2ATAR	CNVX-4115	1/6	503 (19.8)	192 (7.56)	145 (5.71)	47 (1.85)	115 (4.53)	171 (6.73)	140 (5.51)	88 (3.46)	311 (12.2)	-	4050	46 (101.4)
30A2ATBR	CNVX-4115	1/11	503 (19.8)	192 (7.56)	145 (5.71)	47 (1.85)	115 (4.53)	171 (6.73)	140 (5.51)	88 (3.46)	311 (12.2)	-	4970	46 (101.4)
30A2ATCR	CHVX-4145	1/21	582 (22.9)	192 (7.56)	145 (5.71)	47 (1.85)	115 (4.53)	171 (6.73)	140 (5.51)	88 (3.46)	390 (15.4)	209 (8.23)	11590	71 (156.5)

in mm (inches)

Motor type SGMG	Flange dimensions								Shaft end dimensions						
	LA	LB	LC	LE	LG	LR	N	LZ	Q	QK	S	T	U	W	V
05A2ATAR	134 (5.28)	110 ^{-0.036} _{-0.090} (4.33 ^{-0.0014} _{-0.0035})	160 (6.30)	3 (0.12)	9 (0.35)	48 (1.89)	4 (0.16)	11 (0.43)	35 (1.38)	32 (1.26)	φ28 ⁰ _{-0.013} (φ1.10 ⁰ _{-0.0005})	7 (0.28)	4 (0.16)	8 (0.31)	M8 screw, depth 19
05A2ATBR	134 (5.28)	110 ^{-0.036} _{-0.090} (4.33 ^{-0.0014} _{-0.0035})	160 (6.30)	3 (0.12)	9 (0.35)	48 (1.89)	4 (0.16)	11 (0.43)	35 (1.38)	32 (1.26)	φ28 ⁰ _{-0.013} (φ1.10 ⁰ _{-0.0005})	7 (0.28)	4 (0.16)	8 (0.31)	M8 screw, depth 19
05A2ATCR	134 (5.28)	110 ^{-0.036} _{-0.090} (4.33 ^{-0.0014} _{-0.0035})	160 (6.30)	3 (0.12)	9 (0.35)	48 (1.89)	4 (0.16)	11 (0.43)	35 (1.38)	32 (1.26)	φ28 ⁰ _{-0.013} (φ1.10 ⁰ _{-0.0005})	7 (0.28)	4 (0.16)	8 (0.31)	M8 screw, depth 19
05A2AT7R	134 (5.28)	110 ^{-0.036} _{-0.090} (4.33 ^{-0.0014} _{-0.0035})	160 (6.30)	3 (0.12)	9 (0.35)	48 (1.89)	4 (0.16)	11 (0.43)	35 (1.38)	32 (1.26)	φ38 ⁰ _{-0.016} (φ1.50 ⁰ _{-0.0006})	7 (0.28)	4 (0.16)	8 (0.31)	M8 screw, depth 19
09A2ATAR	134 (5.28)	110 ^{-0.036} _{-0.090} (4.33 ^{-0.0014} _{-0.0035})	160 (6.30)	3 (0.12)	9 (0.35)	48 (1.89)	4 (0.16)	11 (0.43)	35 (1.38)	32 (1.26)	φ28 ⁰ _{-0.013} (φ1.10 ⁰ _{-0.0005})	7 (0.28)	4 (0.16)	8 (0.31)	M8 screw, depth 19
09A2ATBR	134 (5.28)	110 ^{-0.036} _{-0.090} (4.33 ^{-0.0014} _{-0.0035})	160 (6.30)	3 (0.12)	9 (0.35)	48 (1.89)	4 (0.16)	11 (0.43)	35 (1.38)	32 (1.26)	φ28 ⁰ _{-0.013} (φ1.10 ⁰ _{-0.0005})	7 (0.28)	4 (0.16)	8 (0.31)	M8 screw, depth 19
09A2ATCR	180 (7.09)	140 ^{-0.043} _{-0.106} (5.51 ^{-0.0017} _{-0.0042})	210 (8.27)	4 (0.16)	13 (0.51)	69 (2.72)	6 (0.24)	11 (0.43)	55 (2.17)	50 (1.97)	φ38 ⁰ _{-0.016} (φ1.50 ⁰ _{-0.0006})	8 (0.31)	5 (0.20)	10 (0.39)	M10 screw, depth 22
09A2AT7R	180 (7.09)	140 ^{-0.043} _{-0.106} (5.51 ^{-0.0017} _{-0.0042})	210 (8.27)	4 (0.16)	13 (0.51)	69 (2.72)	6 (0.24)	11 (0.43)	55 (2.17)	50 (1.97)	φ38 ⁰ _{-0.016} (φ1.50 ⁰ _{-0.0006})	8 (0.31)	5 (0.20)	10 (0.39)	M10 screw, depth 22
13A2ATAR	134 (5.28)	110 ^{-0.036} _{-0.090} (4.33 ^{-0.0014} _{-0.0035})	160 (6.30)	3 (0.12)	9 (0.35)	48 (1.89)	4 (0.16)	11 (0.43)	35 (1.38)	32 (1.26)	φ28 ⁰ _{-0.013} (φ1.10 ⁰ _{-0.0005})	7 (0.28)	4 (0.16)	8 (0.31)	M8 screw, depth 19
13A2ATBR	180 (7.09)	140 ^{-0.043} _{-0.106} (5.51 ^{-0.0017} _{-0.0042})	210 (8.27)	4 (0.16)	13 (0.51)	69 (2.72)	6 (0.24)	11 (0.43)	55 (2.17)	50 (1.97)	φ38 ⁰ _{-0.016} (φ1.50 ⁰ _{-0.0006})	8 (0.31)	5 (0.20)	10 (0.39)	M10 screw, depth 22
13A2ATCR	180 (7.09)	140 ^{-0.043} _{-0.106} (5.51 ^{-0.0017} _{-0.0042})	210 (8.27)	4 (0.16)	13 (0.51)	69 (2.72)	6 (0.24)	11 (0.43)	55 (2.17)	50 (1.97)	φ38 ⁰ _{-0.016} (φ1.50 ⁰ _{-0.0006})	8 (0.31)	5 (0.20)	10 (0.39)	M10 screw, depth 22
20A2ATAR	180 (7.09)	140 ^{-0.043} _{-0.106} (5.51 ^{-0.0017} _{-0.0042})	210 (8.27)	4 (0.16)	13 (0.51)	69 (2.72)	6 (0.24)	11 (0.43)	55 (2.17)	50 (1.97)	φ38 ⁰ _{-0.016} (φ1.50 ⁰ _{-0.0006})	8 (0.31)	5 (0.20)	10 (0.39)	M10 screw, depth 22
20A2ATBR	180 (7.09)	140 ^{-0.043} _{-0.106} (5.51 ^{-0.0017} _{-0.0042})	210 (8.27)	4 (0.16)	13 (0.51)	69 (2.72)	6 (0.24)	11 (0.43)	55 (2.17)	50 (1.97)	φ38 ⁰ _{-0.016} (φ1.50 ⁰ _{-0.0006})	8 (0.31)	5 (0.20)	10 (0.39)	M10 screw, depth 22
30A2ATAR	180 (7.09)	140 ^{-0.043} _{-0.106} (5.51 ^{-0.0017} _{-0.0042})	210 (8.27)	4 (0.16)	13 (0.51)	69 (2.72)	6 (0.24)	11 (0.43)	55 (2.17)	50 (1.97)	φ38 ⁰ _{-0.016} (φ1.50 ⁰ _{-0.0006})	8 (0.31)	5 (0.20)	10 (0.39)	M10 screw, depth 22
30A2ATBR	180 (7.09)	140 ^{-0.043} _{-0.106} (5.51 ^{-0.0017} _{-0.0042})	210 (8.27)	4 (0.16)	13 (0.51)	69 (2.72)	6 (0.24)	11 (0.43)	55 (2.17)	50 (1.97)	φ38 ⁰ _{-0.016} (φ1.50 ⁰ _{-0.0006})	8 (0.31)	5 (0.20)	10 (0.39)	M10 screw, depth 22
30A2ATCR	230 (9.06)	200 ^{-0.050} _{-0.122} (7.87 ^{-0.0020} _{-0.0048})	260 (10.2)	4 (0.16)	15 (0.59)	96 (3.78)	6 (0.24)	11 (0.43)	90 (3.54)	80 (3.15)	φ50 ⁰ _{-0.016} (φ1.97 ⁰ _{-0.0006})	9 (0.35)	5.5 (0.22)	14 (0.55)	M10 screw, depth 18

Oil-lubrication type small size servomotors

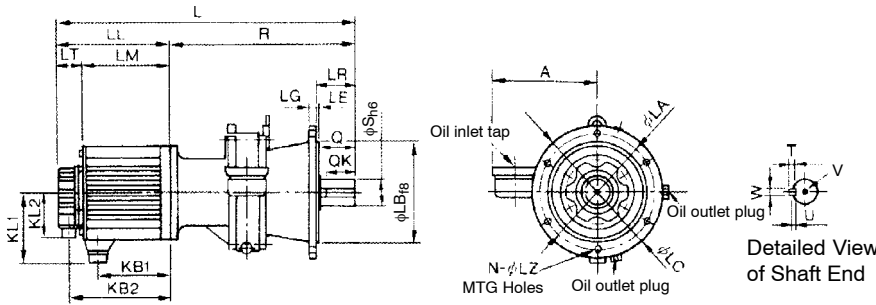

in mm (inches)

Motor type SGMG-	Gear type	Gear ratio	L	LL	LM	LT	KB1	KB2	KL1	KL2	R	A	Axis center allowable radial load N	Approx. mass kg (lb)
13A2AT7R	CHVX-4135	1/29	532 (20.9)	185 (7.28)	139 (5.47)	46 (1.81)	112 (4.41)	164 (6.46)	109 (4.29)	88 (3.46)	347 (13.7)	209 (8.23)	9900	56.6 (124.8)
20A2ATCR	CHVX-4130	1/21	536 (21.1)	166 (6.54)	119 (4.69)	47 (1.85)	89 (3.50)	145 (5.71)	140 (5.51)	88 (3.46)	370 (14.6)	209 (8.23)	8940	66 (145.5)
20A2AT7R	CHVX-4135	1/29	536 (21.1)	166 (6.54)	119 (4.69)	47 (1.85)	89 (3.50)	145 (5.71)	140 (5.51)	88 (3.46)	370 (14.6)	209 (8.23)	9900	66 (145.5)
44A2ATAR	CHVX-4130	1/6	596 (23.5)	226 (8.90)	179 (7.05)	47 (1.85)	149 (5.87)	205 (8.07)	140 (5.51)	88 (3.46)	370 (14.6)	209 (8.23)	5870	75 (165.3)
44A2ATBR	CHVX-4135	1/11	596 (23.5)	226 (8.90)	179 (7.05)	47 (1.85)	149 (5.87)	205 (8.07)	140 (5.51)	88 (3.46)	370 (14.6)	209 (8.23)	7190	75 (165.3)
55A2ATAR	CHVX-4135	1/6	664 (26.1)	260 (10.2)	213 (8.39)	47 (1.85)	174 (6.85)	239 (9.41)	150 (5.91)	88 (3.46)	404 (15.9)	209 (8.23)	5870	87 (191.8)
55A2ATBR	CHVX-4145	1/11	684 (26.9)	260 (10.2)	213 (8.39)	47 (1.85)	174 (6.85)	239 (9.41)	150 (5.91)	88 (3.46)	424 (16.7)	209 (8.23)	9500	88 (194.0)

5

in mm (inches)

Motor type SGMG	Flange dimensions								Shaft end dimensions						
	LA	LB	LC	LE	LG	LR	N	LZ	Q	QK	S	T	U	W	V
13A2AT7R	230 (9.06)	200 ^{-0.050} _{-0.122} (7.87 ^{-0.0020} _{-0.0048})	260 (10.2)	4 (0.16)	15 (0.59)	76 (2.99)	6 (0.24)	11 (0.43)	70 (2.76)	56 (2.20)	φ50 ⁰ _{-0.016} (φ1.97 ⁰ _{-0.0006})	9 (0.35)	5.5 (0.22)	14 (0.55)	M10 screw, depth 18
20A2ATCR	230 (9.06)	200 ^{-0.050} _{-0.122} (7.87 ^{-0.0020} _{-0.0048})	260 (10.2)	4 (0.16)	15 (0.59)	76 (2.99)	6 (0.24)	11 (0.43)	70 (2.76)	56 (2.20)	φ50 ⁰ _{-0.016} (φ1.97 ⁰ _{-0.0006})	9 (0.35)	5.5 (0.22)	14 (0.55)	M10 screw, depth 18
20A2AT7R	230 (9.06)	200 ^{-0.050} _{-0.122} (7.87 ^{-0.0020} _{-0.0048})	260 (10.2)	4 (0.16)	15 (0.59)	76 (2.99)	6 (0.24)	11 (0.43)	70 (2.76)	56 (2.20)	φ50 ⁰ _{-0.016} (φ1.97 ⁰ _{-0.0006})	9 (0.35)	5.5 (0.22)	14 (0.55)	M10 screw, depth 18
44A2ATAR	230 (9.06)	200 ^{-0.050} _{-0.122} (7.87 ^{-0.0020} _{-0.0048})	260 (10.2)	4 (0.16)	15 (0.59)	76 (2.99)	6 (0.24)	11 (0.43)	70 (2.76)	56 (2.20)	φ50 ⁰ _{-0.016} (φ1.97 ⁰ _{-0.0006})	9 (0.35)	5.5 (0.22)	14 (0.55)	M10 screw, depth 18
44A2ATBR	230 (9.06)	200 ^{-0.050} _{-0.122} (7.87 ^{-0.0020} _{-0.0048})	260 (10.2)	4 (0.16)	15 (0.59)	76 (2.99)	6 (0.24)	11 (0.43)	70 (2.76)	56 (2.20)	φ50 ⁰ _{-0.016} (φ1.97 ⁰ _{-0.0006})	9 (0.35)	5.5 (0.22)	14 (0.55)	M10 screw, depth 18
55A2ATAR	230 (9.06)	200 ^{-0.050} _{-0.122} (7.87 ^{-0.0020} _{-0.0048})	260 (10.2)	4 (0.16)	15 (0.59)	76 (2.99)	6 (0.24)	11 (0.43)	70 (2.76)	56 (2.20)	φ50 ⁰ _{-0.016} (φ1.97 ⁰ _{-0.0006})	9 (0.35)	5.5 (0.22)	14 (0.55)	M10 screw, depth 18
55A2ATBR	230 (9.06)	200 ^{-0.050} _{-0.122} (7.87 ^{-0.0020} _{-0.0048})	260 (10.2)	4 (0.16)	15 (0.59)	96 (3.78)	6 (0.24)	11 (0.43)	90 (3.54)	80 (3.15)	φ50 ⁰ _{-0.016} (φ1.97 ⁰ _{-0.0006})	9 (0.35)	5.5 (0.22)	14 (0.55)	M10 screw, depth 18

電話： 037-466333

Email: service@repairtw.com

Line id: @zzzz

www.repairtw.com

Oil-lubrication type large size servomotors

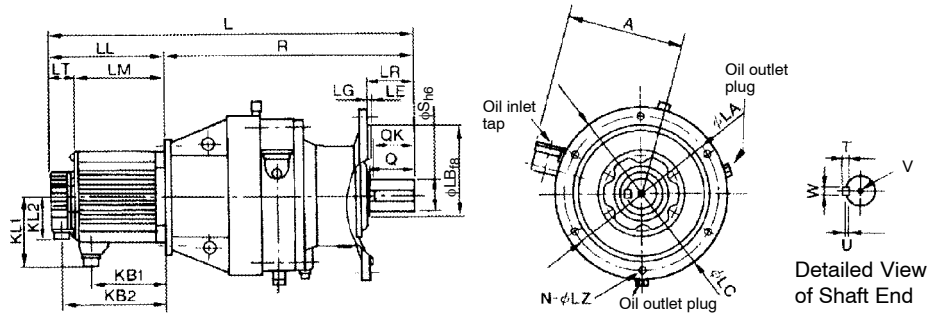

in mm (inches)

Motor type SGMG-	Gear type	Gear ratio	L	LL	LM	LT	KB1	KB2	KL1	KL2	R	A	Axis center allowable radial load N	Approx. mass kg (lb)
30A2AT7R	CHVJ-4160	1/29	687 (27.1)	192 (7.56)	145 (5.71)	47 (1.85)	115 (4.53)	171 (6.73)	140 (5.51)	88 (3.46)	495 (19.5)	228 (8.98)	16290	121 (266.8)
44A2ATCR	CHVJ-4160	1/21	721 (28.4)	226 (8.90)	179 (7.05)	47 (1.85)	149 (5.87)	205 (8.07)	140 (5.51)	88 (3.46)	495 (19.5)	228 (8.98)	14640	126 (277.8)
44A2AT7R	CHVJ-4170	1/29	785 (30.9)	226 (8.90)	179 (7.05)	47 (1.85)	149 (5.87)	205 (8.07)	140 (5.51)	88 (3.46)	559 (22.0)	243 (9.57)	19020	176 (388.0)
55A2ATCR	CHVJ-4170	1/21	853 (33.6)	260 (10.2)	213 (8.39)	47 (1.85)	174 (6.85)	239 (9.41)	150 (5.91)	88 (3.46)	593 (23.4)	243 (9.57)	17180	191 (421.1)
55A2AT7R	CHVJ-4175	1/29	853 (33.6)	260 (10.2)	213 (8.39)	47 (1.85)	174 (6.85)	239 (9.41)	150 (5.91)	88 (3.46)	593 (23.4)	243 (9.57)	19020	191 (421.1)
75A2ATBR	CHVJ-4160	1/11	863 (34.0)	334 (13.2)	287 (11.3)	47 (1.85)	248 (9.76)	313 (12.3)	150 (5.91)	88 (3.46)	529 (20.8)	228 (8.98)	11740	150 (330.7)
75A2ATCR	CHVJ-4175	1/21	927 (36.5)	334 (13.2)	287 (11.3)	47 (1.85)	248 (9.76)	313 (12.3)	150 (5.91)	88 (3.46)	593 (23.4)	243 (9.57)	17180	201 (443.1)
75A2AT7R	CHVJ-4180	1/29	977 (38.5)	334 (13.2)	287 (11.3)	47 (1.85)	248 (9.76)	313 (12.3)	150 (5.91)	88 (3.46)	643 (25.3)	258 (10.2)	25600	232 (511.5)
1AA2ATBR	CHVJ-4170	1/11	934 (36.8)	338 (13.3)	291 (11.5)	47 (1.85)	251 (9.88)	317 (12.5)	168 (6.61)	88 (3.46)	596 (23.5)	243 (9.57)	13800	230.5 (508.2)
1AA2ATCR	CHVJ-4185	1/21	984 (38.7)	338 (13.3)	291 (11.5)	47 (1.85)	251 (9.88)	317 (12.5)	168 (6.61)	88 (3.46)	646 (25.4)	258 (10.2)	23010	263.5 (580.9)
1AA2AT7R	CHVJ-4190	1/29	1077 (42.4)	338 (13.3)	291 (11.5)	47 (1.85)	251 (9.88)	317 (12.5)	168 (6.61)	88 (3.46)	739 (29.1)	285 (11.2)	35810	342.5 (755.1)

USING THE DIGITAL OPERATOR

5.4.1 Servomotor Dimensional Drawings cont.

in mm (inches)

Motor type SGMG	Flange dimensions								Shaft end dimensions						
	LA	LB	LC	LE	LG	LR	N	LZ	Q	QK	S	T	U	W	V
30A2AT7R	310 (12.2)	270 ^{-0.056} _{-0.137} (10.6 ^{-0.0022} _{-0.0054})	340 (13.4)	4 (0.16)	20 (0.79)	89 (3.50)	6 (0.24)	11 (0.43)	90 (3.54)	80 (3.15)	φ60 ⁰ _{-0.019} (φ2.36 ⁰ _{-0.0007})	11 (0.43)	7 (0.28)	18 (0.71)	M10 screw, depth 18
44A2ATCR	310 (12.2)	270 ^{-0.056} _{-0.137} (10.6 ^{-0.0022} _{-0.0054})	340 (13.4)	4 (0.16)	20 (0.79)	89 (3.50)	6 (0.24)	11 (0.43)	90 (3.54)	80 (3.15)	φ60 ⁰ _{-0.019} (φ2.36 ⁰ _{-0.0007})	11 (0.43)	7 (0.28)	18 (0.71)	M10 screw, depth 18
44A2AT7R	360 (14.2)	316 ^{-0.062} _{-0.151} (12.4 ^{-0.0024} _{-0.0059})	400 (15.8)	5 (0.20)	22 (0.87)	94 (3.70)	8 (0.31)	14 (0.55)	90 (3.54)	80 (3.15)	φ70 ⁰ _{-0.016} (φ2.76 ⁰ _{-0.0006})	12 (0.47)	7.5 (0.30)	20 (0.79)	M12 screw, depth 24
55A2ATCR	360 (14.2)	316 ^{-0.062} _{-0.151} (12.4 ^{-0.0024} _{-0.0059})	400 (15.8)	5 (0.20)	22 (0.87)	94 (3.70)	8 (0.31)	14 (0.55)	90 (3.54)	80 (3.15)	φ70 ⁰ _{-0.016} (φ2.76 ⁰ _{-0.0006})	12 (0.47)	7.5 (0.30)	20 (0.79)	M12 screw, depth 24
55A2AT7R	360 (14.2)	316 ^{-0.062} _{-0.151} (12.4 ^{-0.0024} _{-0.0059})	400 (15.8)	5 (0.20)	22 (0.87)	94 (3.70)	8 (0.31)	14 (0.55)	90 (3.54)	80 (3.15)	φ70 ⁰ _{-0.016} (φ2.76 ⁰ _{-0.0006})	12 (0.47)	7.5 (0.30)	20 (0.79)	M12 screw, depth 24
75A2ATBR	310 (12.2)	270 ^{-0.056} _{-0.137} (10.6 ^{-0.0022} _{-0.0054})	340 (13.4)	4 (0.16)	20 (0.79)	89 (3.50)	6 (0.24)	11 (0.43)	90 (3.54)	80 (3.15)	φ60 ⁰ _{-0.019} (φ2.36 ⁰ _{-0.0007})	11 (0.43)	7 (0.28)	18 (0.71)	M10 screw, depth 18
75A2ATCR	360 (14.2)	316 ^{-0.062} _{-0.151} (12.4 ^{-0.0024} _{-0.0059})	400 (15.8)	5 (0.20)	22 (0.87)	94 (3.70)	8 (0.31)	14 (0.55)	90 (3.54)	80 (3.15)	φ70 ⁰ _{-0.016} (φ2.76 ⁰ _{-0.0006})	12 (0.47)	7.5 (0.30)	20 (0.79)	M12 screw, depth 24
75A2AT7R	390 (15.4)	345 ^{-0.062} _{-0.151} (13.58 ^{-0.0024} _{-0.0059})	430 (16.9)	5 (0.20)	22 (0.87)	110 (4.33)	8 (0.31)	18 (0.71)	110 (4.33)	100 (3.94)	φ80 ⁰ _{-0.016} (φ3.15 ⁰ _{-0.0006})	14 (0.55)	9 (0.35)	22 (0.87)	M12 screw, depth 24
1AA2ATBR	360 (14.2)	316 ^{-0.062} _{-0.151} (12.4 ^{-0.0024} _{-0.0059})	400 (15.8)	5 (0.20)	22 (0.87)	94 (3.70)	8 (0.31)	14 (0.55)	90 (3.54)	80 (3.15)	φ70 ⁰ _{-0.016} (φ2.76 ⁰ _{-0.0006})	12 (0.47)	7.5 (0.30)	20 (0.79)	M12 screw, depth 24
1AA2ATCR	390 (15.4)	345 ^{-0.062} _{-0.151} (13.58 ^{-0.0024} _{-0.0059})	430 (16.9)	5 (0.20)	22 (0.87)	100 (3.94)	8 (0.31)	18 (0.71)	110 (4.33)	100 (3.94)	φ80 ⁰ _{-0.016} (φ3.15 ⁰ _{-0.0006})	14 (0.55)	9 (0.35)	22 (0.87)	M12 screw, depth 24
1AA2AT7R	450 (17.7)	400 ^{-0.062} _{-0.151} (15.7 ^{-0.0024} _{-0.0059})	490 (19.3)	6 (0.24)	30 (1.18)	145 (5.71)	12 (0.47)	18 (0.71)	135 (5.31)	125 (4.92)	φ95 ⁰ _{-0.022} (φ3.74 ⁰ _{-0.0009})	14 (0.55)	9 (0.35)	25 (0.98)	M20 screw, depth 34

Email: service@repairtw.com

Line id: @zzzz

www.repairtw.com

Low-backlash gear (1500 min⁻¹), without brake

- Frange-mounted type

Grease-lubrication type small size servomotors

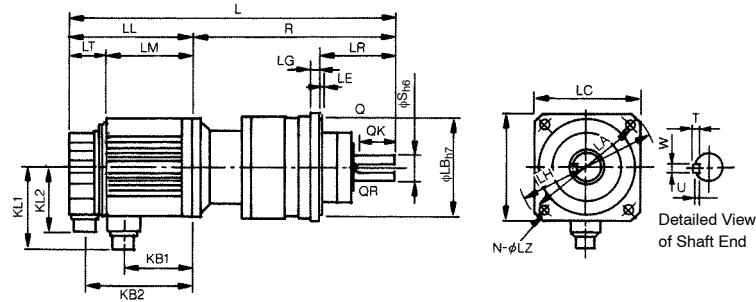

in mm (inches)

Motor type SGMG-	Gear type	Gear ratio	L	LL	LM	LR	LT	KB1	KB2	KL1	KL2	R	Axis center allowable radial load N	Approx. mass kg (lb)
05A2AL1K	BL2	1/5	394 (15.5)	138 (5.43)	92 (3.62)	100 (3.94)	46 (1.81)	65 (2.56)	117 (4.61)	109 (4.29)	88 (3.46)	256 (10.1)	833	14 (30.9)
05A2AL2K		1/9	406 (16.0)	138 (5.43)	92 (3.62)	100 (3.94)	46 (1.81)	65 (2.56)	117 (4.61)	109 (4.29)	88 (3.46)	268 (10.6)	980	14 (30.9)
09A2AL1K		1/5	417 (16.4)	161 (6.34)	115 (4.53)	100 (3.94)	46 (1.81)	88 (3.46)	140 (5.51)	109 (4.29)	88 (3.46)	256 (10.1)	833	16 (35.3)
09A2AL2K		1/9	429 (16.9)	161 (6.34)	115 (4.53)	100 (3.94)	46 (1.81)	88 (3.46)	140 (5.51)	109 (4.29)	88 (3.46)	268 (10.6)	980	16 (35.3)

in mm (inches)

Motor type SGMG-	Flange dimensions							Shaft end dimensions							
	LA	LB	LC	LE	LG	LH	N	LZ	S	Q	QK	QR	T	U	W
05A2AL1K	160 (6.30)	130 ⁰ _{-0.040} (5.12 ⁰ _{-0.0016})	140 (5.51)	3 (0.12)	12 (0.47)	185 (7.28)	4 (0.16)	12 (0.47)	35 ⁰ _{-0.016} (1.38 ⁰ _{-0.0006})	55 (2.17)	47 (1.85)	1 (0.039)	8 (0.31)	5 (0.20)	10 (0.39)
05A2AL2K	160 (6.30)	130 ⁰ _{-0.040} (5.12 ⁰ _{-0.0016})	140 (5.51)	3 (0.12)	12 (0.47)	185 (7.28)	4 (0.16)	12 (0.47)	35 ⁰ _{-0.016} (1.38 ⁰ _{-0.0006})	55 (2.17)	47 (1.85)	1 (0.039)	8 (0.31)	5 (0.20)	10 (0.39)
09A2AL1K	160 (6.30)	130 ⁰ _{-0.040} (5.12 ⁰ _{-0.0016})	140 (5.51)	3 (0.12)	12 (0.47)	185 (7.28)	4 (0.16)	12 (0.47)	35 ⁰ _{-0.016} (1.38 ⁰ _{-0.0006})	55 (2.17)	47 (1.85)	1 (0.039)	8 (0.31)	5 (0.20)	10 (0.39)
09A2AL2K	160 (6.30)	130 ⁰ _{-0.040} (5.12 ⁰ _{-0.0016})	140 (5.51)	3 (0.12)	12 (0.47)	185 (7.28)	4 (0.16)	12 (0.47)	35 ⁰ _{-0.016} (1.38 ⁰ _{-0.0006})	55 (2.17)	47 (1.85)	1 (0.039)	8 (0.31)	5 (0.20)	10 (0.39)

Grease-lubrication type large size servomotors

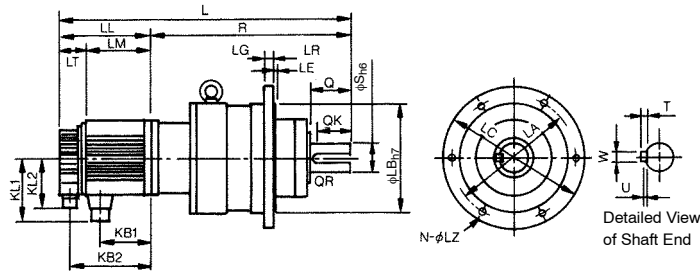

in mm (inches)

Motor type SGMG-	Gear type	Gear ratio	L	LL	LM	LR	LT	KB1	KB2	KL1	KL2	R	Axis center allowable radial load N	Approx. mass kg (lb)
05A2AL5K	BL3	1/20	491 (19.3)	138 (5.43)	92 (3.62)	140 (5.51)	46 (1.81)	65 (2.56)	117 (4.61)	109 (4.29)	88 (3.46)	353 (13.9)	2650	31 (68.3)
05A2AL7K		1/29	491 (19.3)	138 (5.43)	92 (3.62)	140 (5.51)	46 (1.81)	65 (2.56)	117 (4.61)	109 (4.29)	88 (3.46)	353 (13.9)	2940	31 (68.3)
05A2AL8K		1/45	501 (19.7)	138 (5.43)	92 (3.62)	140 (5.51)	46 (1.81)	65 (2.56)	117 (4.61)	109 (4.29)	88 (3.46)	363 (14.3)	3430	31 (68.3)
09A2AL5K		1/20	514 (20.2)	161 (6.34)	115 (4.53)	140 (5.51)	46 (1.81)	88 (3.46)	140 (5.51)	109 (4.29)	88 (3.46)	353 (13.9)	2650	33 (72.8)
09A2AL7K		1/29	514 (20.2)	161 (6.34)	115 (4.53)	140 (5.51)	46 (1.81)	88 (3.46)	140 (5.51)	109 (4.29)	88 (3.46)	353 (13.9)	2940	33 (72.8)
09A2AL8K	BL4	1/45	565 (22.2)	161 (6.34)	115 (4.53)	160 (6.30)	46 (1.81)	88 (3.46)	140 (5.51)	109 (4.29)	88 (3.46)	404 (15.9)	8040	53 (116.8)
13A2AL1K	BL3	1/5	507 (20.0)	185 (7.28)	139 (5.47)	140 (5.51)	46 (1.81)	112 (4.41)	164 (6.46)	109 (4.29)	88 (3.46)	322 (12.7)	1670	28 (61.7)
13A2AL2K		1/9	534 (21.0)	185 (7.28)	139 (5.47)	140 (5.51)	46 (1.81)	112 (4.41)	164 (6.46)	109 (4.29)	88 (3.46)	349 (13.7)	1960	35 (77.1)
13A2AL5K		1/20	538 (21.2)	185 (7.28)	139 (5.47)	140 (5.51)	46 (1.81)	112 (4.41)	164 (6.46)	109 (4.29)	88 (3.46)	353 (13.9)	2650	35 (77.1)
13A2AL7K	BL4	1/29	579 (22.8)	185 (7.28)	139 (5.47)	160 (6.30)	46 (1.81)	112 (4.41)	164 (6.46)	109 (4.29)	88 (3.46)	394 (15.5)	6860	55 (121.3)
13A2AL8K		1/45	589 (23.2)	185 (7.28)	139 (5.47)	160 (6.30)	46 (1.81)	112 (4.41)	164 (6.46)	109 (4.29)	88 (3.46)	404 (15.9)	8040	55 (121.3)
20A2AL1K	BL3	1/5	509 (20.0)	166 (6.54)	119 (4.69)	140 (5.51)	47 (1.85)	89 (3.50)	145 (5.71)	140 (5.51)	88 (3.46)	343 (13.5)	1670	32 (70.5)
20A2AL2K		1/9	536 (21.1)	166 (6.54)	119 (4.69)	140 (5.51)	47 (1.85)	89 (3.50)	145 (5.71)	140 (5.51)	88 (3.46)	370 (14.6)	1960	39 (86.0)
20A2AL5K	BL4	1/20	581 (22.9)	166 (6.54)	119 (4.69)	160 (6.30)	47 (1.85)	89 (3.50)	145 (5.71)	140 (5.51)	88 (3.46)	415 (16.3)	6080	39 (86.0)
20A2AL7K		1/29	581 (22.9)	166 (6.54)	119 (4.69)	160 (6.30)	47 (1.85)	89 (3.50)	145 (5.71)	140 (5.51)	88 (3.46)	415 (16.3)	6860	39 (86.0)
30A2AL1K		1/5	575 (22.6)	192 (7.56)	145 (5.71)	160 (6.30)	47 (1.85)	115 (4.53)	171 (6.73)	140 (5.51)	88 (3.46)	383 (15.1)	3820	53 (116.8)
30A2AL2K		1/9	607 (23.9)	192 (7.56)	145 (5.71)	160 (6.30)	47 (1.85)	115 (4.53)	171 (6.73)	140 (5.51)	88 (3.46)	415 (16.3)	4700	63 (138.9)
30A2AL5K		1/20	607 (23.9)	192 (7.56)	145 (5.71)	160 (6.30)	47 (1.85)	115 (4.53)	171 (6.73)	140 (5.51)	88 (3.46)	415 (16.3)	6080	63 (138.9)
44A2AL1K	BL4	1/5	609 (24.0)	226 (8.90)	179 (7.05)	160 (6.30)	47 (1.85)	149 (5.87)	205 (8.07)	140 (5.51)	88 (3.46)	383 (15.1)	3820	58 (127.9)
44A2AL2K		1/9	641 (25.2)	226 (8.90)	179 (7.05)	160 (6.30)	47 (1.85)	149 (5.87)	205 (8.07)	140 (5.51)	88 (3.46)	415 (16.3)	4700	68 (149.9)

5

in mm (inches)

Motor type SGMG-	Flange dimensions							Shaft end dimensions						
	LA	LB	LC	LE	LG	N	LZ	S	Q	QK	QR	T	U	W
05A2AL5K	220 (8.66)	$190^{0}_{-0.046}$ $(7.48^{0}_{-0.0018})$	245 (9.65)	5 (0.20)	15 (0.59)	6 (0.24)	12 (0.47)	$50^{0}_{-0.016}$ $(1.97^{0}_{-0.0006})$	75 (2.95)	65 (2.56)	1 (0.039)	9 (0.35)	5.5 (0.22)	14 (0.55)
05A2AL7K	220 (8.66)	$190^{0}_{-0.046}$ $(7.48^{0}_{-0.0018})$	245 (9.65)	5 (0.20)	15 (0.59)	6 (0.24)	12 (0.47)	$50^{0}_{-0.016}$ $(1.97^{0}_{-0.0006})$	75 (2.95)	65 (2.56)	1 (0.039)	9 (0.35)	5.5 (0.22)	14 (0.55)
05A2AL8K	220 (8.66)	$190^{0}_{-0.046}$ $(7.48^{0}_{-0.0018})$	245 (9.65)	5 (0.20)	15 (0.59)	6 (0.24)	12 (0.47)	$50^{0}_{-0.016}$ $(1.97^{0}_{-0.0006})$	75 (2.95)	65 (2.56)	1 (0.039)	9 (0.35)	5.5 (0.22)	14 (0.55)
09A2AL5K	220 (8.66)	$190^{0}_{-0.046}$ $(7.48^{0}_{-0.0018})$	245 (9.65)	5 (0.20)	15 (0.59)	6 (0.24)	12 (0.47)	$50^{0}_{-0.016}$ $(1.97^{0}_{-0.0006})$	75 (2.95)	65 (2.56)	1 (0.039)	9 (0.35)	5.5 (0.22)	14 (0.55)
09A2AL7K	220 (8.66)	$190^{0}_{-0.046}$ $(7.48^{0}_{-0.0018})$	245 (9.65)	5 (0.20)	15 (0.59)	6 (0.24)	12 (0.47)	$50^{0}_{-0.016}$ $(1.97^{0}_{-0.0006})$	75 (2.95)	65 (2.56)	1 (0.039)	9 (0.35)	5.5 (0.22)	14 (0.55)
09A2AL8K	280 (11.0)	$240^{0}_{-0.046}$ $(9.45^{0}_{-0.0018})$	310 (12.2)	5 (0.20)	18 (0.71)	6 (0.24)	14 (0.55)	$60^{0}_{-0.019}$ $(2.36^{0}_{-0.0007})$	90 (3.54)	78 (3.07)	1 (0.039)	11 (0.43)	7 (0.28)	18 (0.71)
13A2AL1K	220 (8.66)	$190^{0}_{-0.046}$ $(7.48^{0}_{-0.0018})$	245 (9.65)	5 (0.20)	15 (0.59)	6 (0.24)	12 (0.47)	$50^{0}_{-0.016}$ $(1.97^{0}_{-0.0006})$	75 (2.95)	65 (2.56)	1 (0.039)	9 (0.35)	5.5 (0.22)	14 (0.55)
13A2AL2K	220 (8.66)	$190^{0}_{-0.046}$ $(7.48^{0}_{-0.0018})$	245 (9.65)	5 (0.20)	15 (0.59)	6 (0.24)	12 (0.47)	$50^{0}_{-0.016}$ $(1.97^{0}_{-0.0006})$	75 (2.95)	65 (2.56)	1 (0.039)	9 (0.35)	5.5 (0.22)	14 (0.55)
13A2AL5K	220 (8.66)	$190^{0}_{-0.046}$ $(7.48^{0}_{-0.0018})$	245 (9.65)	5 (0.20)	15 (0.59)	6 (0.24)	12 (0.47)	$50^{0}_{-0.016}$ $(1.97^{0}_{-0.0006})$	75 (2.95)	65 (2.56)	1 (0.039)	9 (0.35)	5.5 (0.22)	14 (0.55)
13A2AL7K	280 (11.0)	$240^{0}_{-0.046}$ $(9.45^{0}_{-0.0018})$	310 (12.2)	5 (0.20)	18 (0.71)	6 (0.24)	14 (0.55)	$60^{0}_{-0.019}$ $(2.36^{0}_{-0.0007})$	90 (3.54)	78 (3.07)	1 (0.039)	11 (0.43)	7 (0.28)	18 (0.71)
13A2AL8K	280 (11.0)	$240^{0}_{-0.046}$ $(9.45^{0}_{-0.0018})$	310 (12.2)	5 (0.20)	18 (0.71)	6 (0.24)	14 (0.55)	$60^{0}_{-0.019}$ $(2.36^{0}_{-0.0007})$	90 (3.54)	78 (3.07)	1 (0.039)	11 (0.43)	7 (0.28)	18 (0.71)
20A2AL1K	220 (8.66)	$190^{0}_{-0.046}$ $(7.48^{0}_{-0.0018})$	245 (9.65)	5 (0.20)	15 (0.59)	6 (0.24)	12 (0.47)	$50^{0}_{-0.016}$ $(1.97^{0}_{-0.0006})$	75 (2.95)	65 (2.56)	1 (0.039)	9 (0.35)	5.5 (0.22)	14 (0.55)
20A2AL2K	220 (8.66)	$190^{0}_{-0.046}$ $(7.48^{0}_{-0.0018})$	245 (9.65)	5 (0.20)	15 (0.59)	6 (0.24)	12 (0.47)	$50^{0}_{-0.016}$ $(1.97^{0}_{-0.0006})$	75 (2.95)	65 (2.56)	1 (0.039)	9 (0.35)	5.5 (0.22)	14 (0.55)
20A2AL5K	280 (11.0)	$240^{0}_{-0.046}$ $(9.45^{0}_{-0.0018})$	310 (12.2)	5 (0.20)	18 (0.71)	6 (0.24)	14 (0.55)	$60^{0}_{-0.019}$ $(2.36^{0}_{-0.0007})$	90 (3.54)	78 (3.07)	1 (0.039)	11 (0.43)	7 (0.28)	18 (0.71)
20A2AL7K	280 (11.0)	$240^{0}_{-0.046}$ $(9.45^{0}_{-0.0018})$	310 (12.2)	5 (0.20)	18 (0.71)	6 (0.24)	14 (0.55)	$60^{0}_{-0.019}$ $(2.36^{0}_{-0.0007})$	90 (3.54)	78 (3.07)	1 (0.039)	11 (0.43)	7 (0.28)	18 (0.71)
30A2AL1K	280 (11.0)	$240^{0}_{-0.046}$ $(9.45^{0}_{-0.0018})$	310 (12.2)	5 (0.20)	18 (0.71)	6 (0.24)	14 (0.55)	$60^{0}_{-0.019}$ $(2.36^{0}_{-0.0007})$	90 (3.54)	78 (3.07)	1 (0.039)	11 (0.43)	7 (0.28)	18 (0.71)
30A2AL2K	280 (11.0)	$240^{0}_{-0.046}$ $(9.45^{0}_{-0.0018})$	310 (12.2)	5 (0.20)	18 (0.71)	6 (0.24)	14 (0.55)	$60^{0}_{-0.019}$ $(2.36^{0}_{-0.0007})$	90 (3.54)	78 (3.07)	1 (0.039)	11 (0.43)	7 (0.28)	18 (0.71)
30A2AL5K	280 (11.0)	$240^{0}_{-0.046}$ $(9.45^{0}_{-0.0018})$	310 (12.2)	5 (0.20)	18 (0.71)	6 (0.24)	14 (0.55)	$60^{0}_{-0.019}$ $(2.36^{0}_{-0.0007})$	90 (3.54)	78 (3.07)	1 (0.039)	11 (0.43)	7 (0.28)	18 (0.71)
44A2AL1K	280 (11.0)	$240^{0}_{-0.046}$ $(9.45^{0}_{-0.0018})$	310 (12.2)	5 (0.20)	18 (0.71)	6 (0.24)	14 (0.55)	$60^{0}_{-0.019}$ $(2.36^{0}_{-0.0007})$	90 (3.54)	78 (3.07)	1 (0.039)	11 (0.43)	7 (0.28)	18 (0.71)
44A2AL2K	280 (11.0)	$240^{0}_{-0.046}$ $(9.45^{0}_{-0.0018})$	310 (12.2)	5 (0.20)	18 (0.71)	6 (0.24)	14 (0.55)	$60^{0}_{-0.019}$ $(2.36^{0}_{-0.0007})$	90 (3.54)	78 (3.07)	1 (0.039)	11 (0.43)	7 (0.28)	18 (0.71)

Shaft end tap specifications

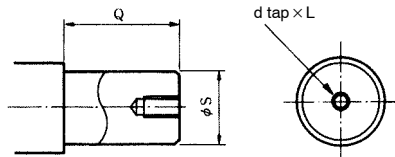

in mm (inches)

Gear type	Shaft diameter S	Shaft length Q	d x L
BL2	35 (1.38)	55 (2.17)	M8 x 16
BL3	50 (1.97)	75 (2.95)	M10 x 20
BL4	60 (2.36)	90 (3.54)	M12 x 24

Detailed dimensions of IMT gear

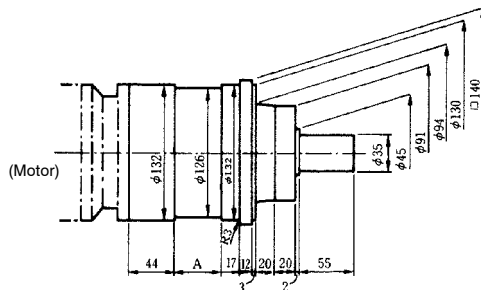

(BL 2)

in mm (inches)

Gear ratio	A
1/5	6 (0.24)
1/9	18 (0.71)
1/20, 1/29	39 (1.54)
1/45	47 (1.85)

5

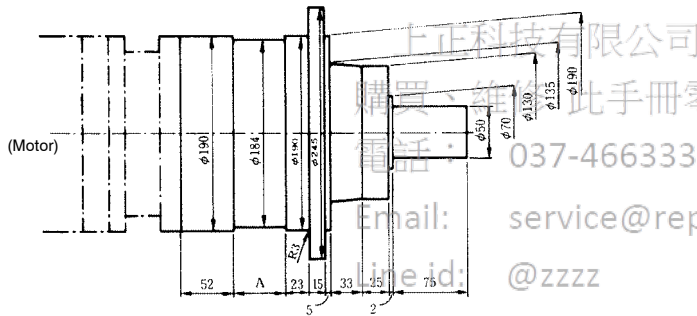

(BL 3)

in mm (inches)

Gear ratio	A
1/5	11 (0.43)
1/9	38 (1.50)
1/20, 1/29	46 (1.81)
1/45	52 (2.05)

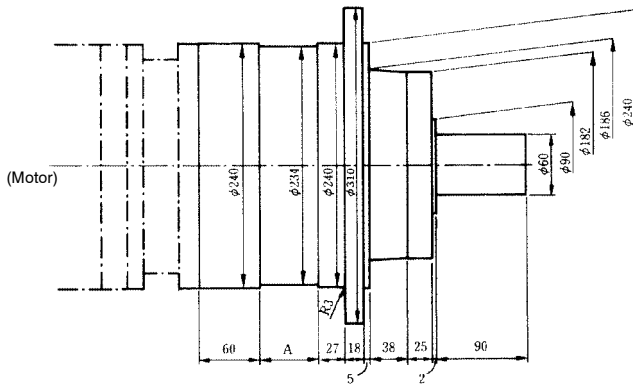

(BL 4)

in mm (inches)

Gear ratio	A
1/5	16 (0.63)
1/9	48 (1.89)
1/20, 1/29	55 (2.17)
1/45	58 (2.28)

■ SGMG-□□A□B Servomotor (1000 min⁻¹)

Incremental encoder (8192 P/R)

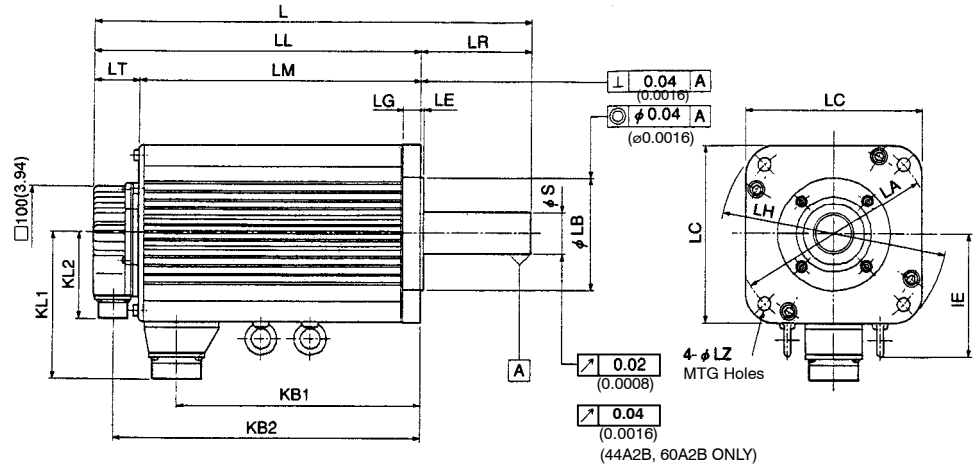

Detailed View of Shaft End for SGMG-03A2B to -09A2B

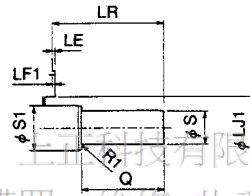

Detailed View of Shaft End for SGMG-12A2B to -60A2B

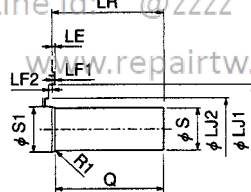

上海科捷有限公司
 購買、維修 此手冊零組件
 電話： 037-466333
 Email: service@repairtw.com

Line id: LR @zzzz
 www.repairtw.com

USING THE DIGITAL OPERATOR

5.4.1 Servomotor Dimensional Drawings cont.

in mm (inches)

Type SGMG-	L	LL	LM	LR	LT	KB1	KB2	IE	KL1	KL2
03A2B	196 (7.72)	138 (5.43)	92 (3.62)	58 (2.28)	46 (1.81)	65 (2.56)	117 (4.61)	-	109 (4.29)	88 (3.46)
06A2B	219 (8.62)	161 (6.34)	115 (4.53)	58 (2.28)	46 (1.81)	88 (3.46)	140 (5.51)	-	109 (4.29)	88 (3.46)
09A2B	243 (9.57)	185 (7.28)	139 (5.47)	58 (2.28)	46 (1.81)	112 (4.41)	164 (6.46)	-	109 (4.29)	88 (3.46)
12A2B	245 (9.65)	166 (6.54)	119 (4.69)	79 (3.11)	47 (1.85)	89 (3.50)	145 (5.71)	-	140 (5.51)	88 (3.46)
20A2B	271 (10.67)	192 (7.56)	145 (5.71)	79 (3.11)	47 (1.85)	115 (4.53)	171 (6.73)	-	140 (5.51)	88 (3.46)
30A2B	305 (12.01)	226 (8.90)	179 (7.05)	79 (3.11)	47 (1.85)	149 (5.87)	205 (8.07)	-	140 (5.51)	88 (3.46)
44A2B	373 (14.69)	260 (10.24)	213 (8.39)	113 (4.45)	47 (1.85)	174 (6.85)	239 (9.41)	125 (4.92)	150 (5.91)	88 (3.46)
60A2B	447 (17.60)	334 (13.15)	287 (11.30)	113 (4.45)	47 (1.85)	248 (9.76)	313 (12.32)	125 (4.92)	150 (5.91)	88 (3.46)

in mm (inches)

Type SGMG-	Flange dimensions										
	LA	LB	LC	LE	LF1	LF2	LG	LH	LJ1	LJ2	LZ
03A2B	145 (5.71)	110 ⁰ _{-0.035} (4.33 - 0.0014)	130 (5.12)	6 (0.24)	6 (0.24)	-	12 (0.47)	165 (6.50)	45 (1.77)	-	9 (0.35)
06A2B	145 (5.71)	110 ⁰ _{-0.035} (4.33 - 0.0014)	130 (5.12)	6 (0.24)	6 (0.24)	-	12 (0.47)	165 (6.50)	45 (1.77)	-	9 (0.35)
09A2B	145 (5.71)	110 ⁰ _{-0.035} (4.33 - 0.0014)	130 (5.12)	6 (0.24)	6 (0.24)	-	12 (0.47)	165 (6.50)	45 (1.77)	-	9 (0.35)
12A2B	200 (7.87)	114.3 ⁰ _{-0.025} (4.50 - 0.0010)	180 (7.09)	3.2 (0.13)	3 (0.12)	0.5 (0.0197)	18 (0.71)	230 (9.06)	76 (2.99)	62 (2.44)	13.5 (0.53)
20A2B	200 (7.87)	114.3 ⁰ _{-0.025} (4.50 - 0.0010)	180 (7.09)	3.2 (0.13)	3 (0.12)	0.5 (0.0197)	18 (0.71)	230 (9.06)	76 (2.99)	62 (2.44)	13.5 (0.53)
30A2B	200 (7.87)	114.3 ⁰ _{-0.025} (4.50 - 0.0010)	180 (7.09)	3.2 (0.13)	3 (0.12)	0.5 (0.0197)	18 (0.71)	230 (9.06)	76 (2.99)	62 (2.44)	13.5 (0.53)
44A2B	200 (7.87)	114.3 ⁰ _{-0.025} (4.50 - 0.0010)	180 (7.09)	3.2 (0.13)	3 (0.12)	0.5 (0.0197)	18 (0.71)	230 (9.06)	76 (2.99)	62 (2.44)	13.5 (0.53)
60A2B	200 (7.87)	114.3 ⁰ _{-0.025} (4.50 - 0.0010)	180 (7.09)	3.2 (0.13)	3 (0.12)	0.5 (0.0197)	18 (0.71)	230 (9.06)	76 (2.99)	62 (2.44)	13.5 (0.53)

in mm (inches)

Type SGMG-	Shaft end dimensions			Approx. mass kg (lb)
	S	S1	Q	
03A2B	$19 \begin{smallmatrix} 0 \\ - 0.013 \\ 0 \end{smallmatrix}$ (0.75 - 0.0005)	30 (1.18)	40 (1.57)	5.5 (12.12)
06A2B	$19 \begin{smallmatrix} 0 \\ - 0.013 \\ 0 \end{smallmatrix}$ (0.75 - 0.0005)	30 (1.18)	40 (1.57)	7.6 (16.75)
09A2B	$22 \begin{smallmatrix} 0 \\ - 0.013 \\ 0 \end{smallmatrix}$ (0.87 - 0.0005)	30 (1.18)	40 (1.57)	9.6 (21.16)
12A2B	$35 \begin{smallmatrix} + 0.01 \\ 0 \\ + 0.0004 \\ 0 \end{smallmatrix}$ (1.38 + 0.0004)	45 (1.77)	76 (2.99)	14 (30.86)
20A2B	$35 \begin{smallmatrix} + 0.01 \\ 0 \\ + 0.0004 \\ 0 \end{smallmatrix}$ (1.38 + 0.0004)	45 (1.77)	76 (2.99)	18 (39.62)
30A2B	$35 \begin{smallmatrix} + 0.01 \\ 0 \\ + 0.0004 \\ 0 \end{smallmatrix}$ (1.38 + 0.0004)	45 (1.77)	76 (2.99)	23 (50.69)
44A2B	$42 \begin{smallmatrix} 0 \\ - 0.016 \\ 0 \end{smallmatrix}$ (1.65 - 0.0006)	45 (1.77)	110 (4.33)	30 (66.12)
60A2B	$42 \begin{smallmatrix} 0 \\ - 0.016 \\ 0 \end{smallmatrix}$ (1.65 - 0.0006)	45 (1.77)	110 (4.33)	40 (88.16)

- Note**
- 1) Incremental encoder (8192 P/R) is used as a detector.
 - 2) SGMG-03A2B to -30A2B do not contain eyebolts.

• Connector Wiring on Detector Side

Receptacle: MS3102A20-29P

Plug (To be prepared by customer) (L type): MS3108B20-29S or
(Straight type) MS3106B20-29S

Cable Clamp: (To be prepared by customer) MS3057-12A

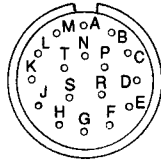

Encoder Wiring Specifications

A	A channel output	K	
B	\bar{A} channel output	L	
C	B channel output	M	
D	\bar{B} channel output	N	
E	C channel output	P	
F	\bar{C} channel output	R	
G	0V	S	
H	+5V DC	T	
J	FG (Frame Ground)		

Note 1) Terminals K to T are not used.

2) Receptacle, plug and cable clamp are common regardless of motor capacity.

• Connector Wiring on Motor Side

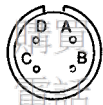

Motor Wiring Specifications

A	Phase U
B	Phase V
C	Phase W
D	Ground terminal

Note Receptacle, plug and cable clamp differ depending on the capacity. Refer to 6) Connectors on Detector and Motor Sides (page 392).

Incremental encoder (8192 P/R), with brake

• 0.3 to 3.0kW

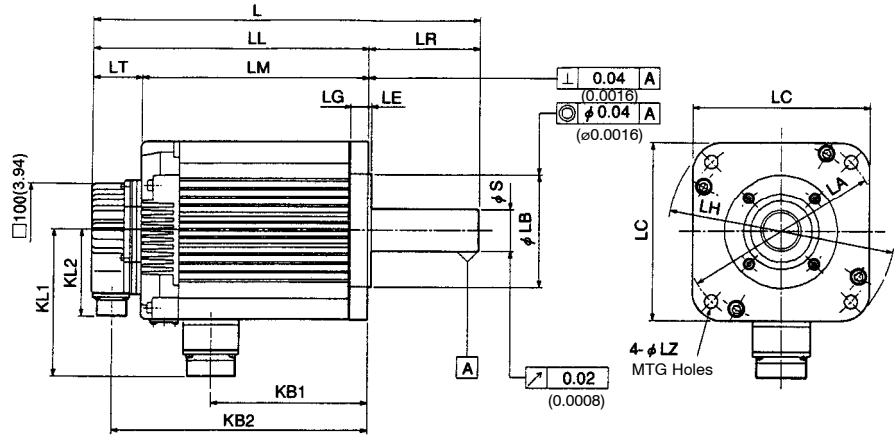

Detailed View of Shaft End for SGMG-03A2BAB to -09A2BAB

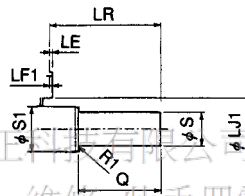

購買、維修 此手冊零組件

電話： 037-466333

Detailed View of Shaft End for SGMG-12A2BAB to -30A2BAB

Email: service@repairtw.com

Line id: @LR77

www.repairtw.com

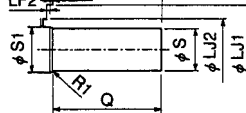

USING THE DIGITAL OPERATOR

5.4.1 Servomotor Dimensional Drawings cont.

in mm (inches)

Type SGMG-	Flange dimensions										
	LA	LB	LC	LE	LF1	LF2	LG	LH	LJ1	LJ2	LZ
03A2BAB	145 (5.71)	110 ⁰ _{-0.035} (4.33 ⁰ _{-0.0014})	130 (5.12)	6 (0.24)	6 (0.24)	-	12 (0.47)	165 (6.50)	45 (1.77)	-	9 (0.35)
06A2BAB	145 (5.71)	110 ⁰ _{-0.035} (4.33 ⁰ _{-0.0014})	130 (5.12)	6 (0.24)	6 (0.24)	-	12 (0.47)	165 (6.50)	45 (1.77)	-	9 (0.35)
09A2BAB	145 (5.71)	110 ⁰ _{-0.035} (4.33 ⁰ _{-0.0014})	130 (5.12)	6 (0.24)	6 (0.24)	-	12 (0.47)	165 (6.50)	45 (1.77)	-	9 (0.35)
12A2BAB	200 (7.87)	114.3 ⁰ _{-0.025} (4.50 ⁰ _{-0.0010})	180 (7.09)	3.2 (0.13)	3 (0.12)	0.5 (0.0197)	18 (0.71)	230 (9.06)	76 (2.99)	62 (2.44)	13.5 (0.53)
20A2BAB	200 (7.87)	114.3 ⁰ _{-0.025} (4.50 ⁰ _{-0.0010})	180 (7.09)	3.2 (0.13)	3 (0.12)	0.5 (0.0197)	18 (0.71)	230 (9.06)	76 (2.99)	62 (2.44)	13.5 (13.5)
30A2BAB	200 (7.87)	114.3 ⁰ _{-0.025} (4.50 ⁰ _{-0.0010})	180 (7.09)	3.2 (0.13)	3 (0.12)	0.5 (0.0197)	18 (0.71)	230 (9.06)	76 (2.99)	62 (2.44)	13.5 (0.53)

5

上正科技有限公司

購買、維修 此手冊零組件

電話： 037-466333

Email: service@repairtw.com

Line id: @zzzz

www.repairtw.com

in mm (inches)

Type SGMG-	Shaft end dimensions			Approx. mass kg (lb)
	S	S1	Q	
03A2BAB	$19 \begin{smallmatrix} 0 \\ - 0.013 \\ 0 \end{smallmatrix}$ (0.75 - 0.0005)	30 (1.18)	40 (1.57)	7.5 (16.53)
06A2BAB	$19 \begin{smallmatrix} 0 \\ - 0.013 \\ 0 \end{smallmatrix}$ (0.75 - 0.0005)	30 (1.18)	40 (1.57)	9.6 (21.16)
09A2BAB	$22 \begin{smallmatrix} 0 \\ - 0.013 \\ 0 \end{smallmatrix}$ (0.87 - 0.0005)	30 (1.18)	40 (1.57)	12 (26.45)
12A2BAB	$35 \begin{smallmatrix} + 0.01 \\ 0 \\ + 0.0004 \\ 0 \end{smallmatrix}$ (1.38)	45 (1.77)	76 (2.99)	19 (41.88)
20A2BAB	$35 \begin{smallmatrix} + 0.01 \\ 0 \\ + 0.0004 \\ 0 \end{smallmatrix}$ (1.38)	45 (1.77)	76 (2.99)	23.5 (51.79)
30A2BAB	$35 \begin{smallmatrix} + 0.01 \\ 0 \\ + 0.0004 \\ 0 \end{smallmatrix}$ (1.38)	45 (1.77)	76 (2.99)	28.5 (62.81)

Note Incremental encoder (8192 P/R) is used as a detector.

- Connector Wiring on Motor Side



A	Phase U	E	Brake terminal
B	Phase V	F	Brake terminal
C	Phase W	G	-
D	Frame ground (FG)		

• 4.4 to 6.0kW

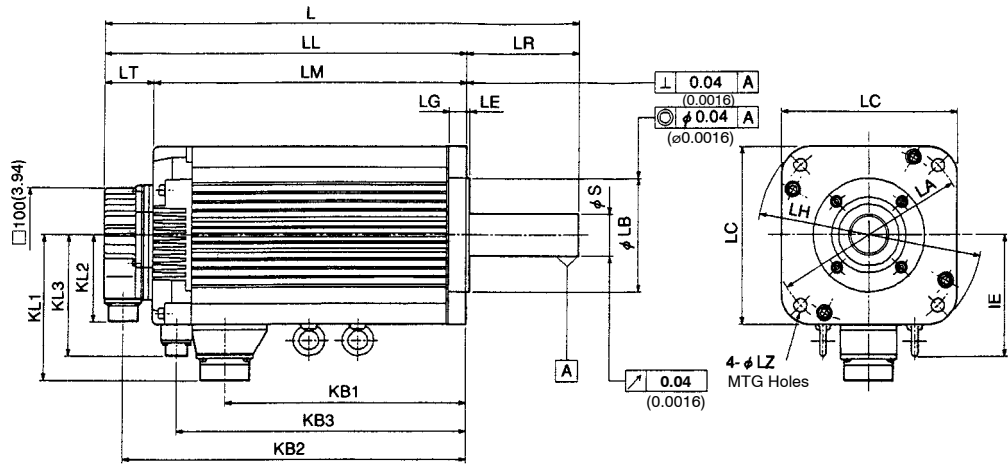

Detailed View of Shaft End

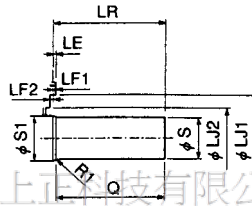

上正科技有限公司

購買、維修 此手冊零組件

電話： 037-466333

in mm (inches)

Type SGMG-	L	LL	LM	LR	LT	KB1	KB2	KB3	IE	KL1	KL2	KL3
44A2BAB	424 (16.69)	311 (12.24)	264 (10.39)	113 (4.45)	47 (1.85)	174 (6.85)	290 (11.42)	231 (9.09)	125 (4.92)	150 (5.91)	88 (3.46)	123 (4.84)
60A2BAB	498 (19.61)	385 (15.16)	338 (13.31)	113 (4.45)	47 (1.85)	248 (9.76)	364 (14.33)	305 (12.01)	125 (4.92)	150 (5.91)	88 (3.46)	123 (4.84)

in mm (inches)

Type SGMG-	Flange dimensions										
	LA	LB	LC	LE	LF1	LF2	LG	LH	LJ1	LJ2	LZ
44A2BAB	200 (7.87)	114.3 ⁰ _{-0.025} (4.50 ⁰ _{-0.0010})	180 (7.09)	3.2 (0.13)	3 (0.12)	0.5 (0.0197)	18 (0.71)	230 (9.06)	76 (2.99)	62 (2.44)	13.5 (0.53)
60A2BAB	200 (7.87)	114.3 ⁰ _{-0.025} (4.50 ⁰ _{-0.0010})	180 (7.09)	3.2 (0.13)	3 (0.12)	0.5 (0.0197)	18 (0.71)	230 (9.06)	76 (2.99)	62 (2.44)	13.5 (0.53)

in mm (inches)

Type SGMG-	Shaft end dimensions			Approx. mass kg (lb)
	S	S1	Q	
44A2BAB	$42 \begin{smallmatrix} 0 \\ - 0.016 \\ 0 \\ (1.65 - 0.0006) \end{smallmatrix}$	45 (1.77)	110 (4.33)	35 (77.14)
60A2BAB	$42 \begin{smallmatrix} 0 \\ - 0.016 \\ 0 \\ (1.65 - 0.0006) \end{smallmatrix}$	45 (1.77)	110 (4.33)	45.5 (100.28)

Note Incremental encoder (8192 P/R) is used as a detector.

- Connector Wiring on Motor Side



A	Brake terminal
B	Brake terminal
C	

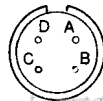

A	Phase U
B	Phase V
C	Phase W
D	Frame ground (FG)

上正科技有限公司

購買、維修 此手冊零組件

電話： 037-466333

Email: service@repairtw.com

Line id: @zzzz

www.repairtw.com

Absolute encoder (15bit : 8192 P/R, 12 bit : 1024 P/R)

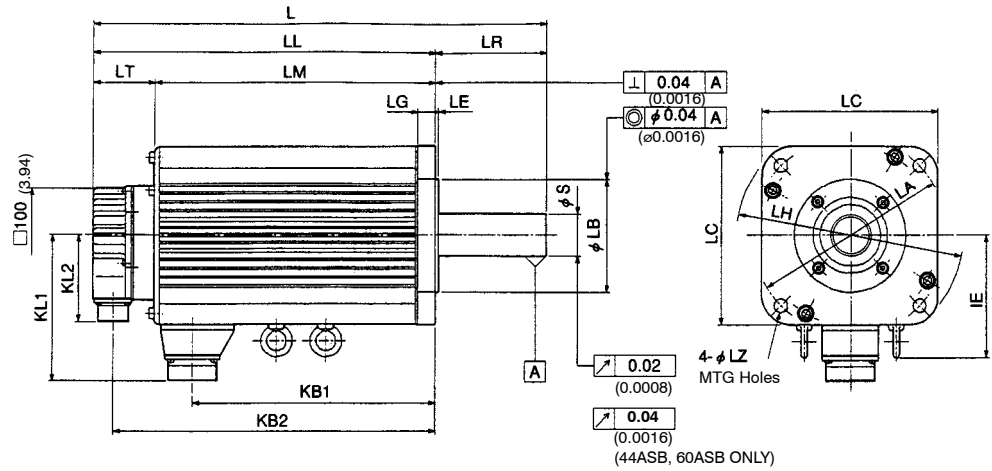

Detailed View of Shaft End for SGMG-03ASB to -09ASB

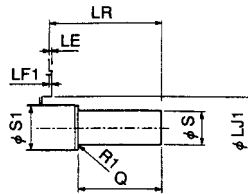

Detailed View of Shaft End for SGMG-12ASB to -60ASB

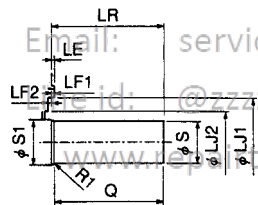

上正科技有限公司

購買、維修、此手冊電組件

電話： 037-466333

Email: service@repairtw.com

Website: www.repairtw.com

www.repairtw.com

in mm (inches)

Type SGMG-	L	LL	LM	LR	LT	KB1	KB2	IE	KL1	KL2
03ASB	210 (8.27)	152 (5.98)	92 (3.62)	58 (2.28)	60 (2.36)	65 (2.56)	131 (5.16)	-	109 (4.29)	88 (3.46)
06ASB	233 (9.17)	175 (6.89)	115 (4.53)	58 (2.28)	60 (2.36)	88 (3.46)	154 (6.06)	-	109 (4.29)	88 (3.46)
09ASB	257 (10.12)	199 (7.83)	139 (5.47)	58 (2.28)	60 (2.36)	112 (4.41)	178 (7.01)	-	109 (4.29)	88 (3.46)
12ASB	259 (10.20)	180 (7.09)	119 (4.69)	79 (3.11)	61 (2.40)	89 (3.50)	159 (6.26)	-	140 (5.51)	88 (3.46)
20ASB	285 (11.22)	206 (8.11)	145 (5.71)	79 (3.11)	61 (2.40)	115 (4.53)	185 (7.28)	-	140 (5.51)	88 (3.46)
30ASB	319 (12.56)	240 (9.45)	179 (7.05)	79 (3.11)	61 (2.40)	149 (5.87)	219 (8.62)	-	140 (5.51)	88 (3.46)
44ASB	387 (15.24)	274 (10.79)	213 (8.39)	113 (4.45)	61 (2.40)	174 (6.85)	253 (9.96)	125 (4.92)	150 (5.91)	88 (3.46)
60ASB	461 (18.15)	348 (13.70)	287 (11.30)	113 (4.45)	61 (2.40)	248 (9.76)	327 (12.87)	125 (4.92)	150 (5.91)	88 (3.46)

in mm (inches)

Type SGMG-	Flange dimensions										
	LA	LB	LC	LE	LF1	LF2	LG	LH	LJ1	LJ2	LZ
03ASB	145 (5.71)	110 ⁰ _{-0.035} (4.33 - 0.0014)	130 (5.12)	6 (0.24)	6 (0.24)	-	12 (0.47)	165 (6.50)	45 (1.77)	-	9 (0.35)
06ASB	145 (5.71)	110 ⁰ _{-0.035} (4.33 - 0.0014)	130 (5.12)	6 (0.24)	6 (0.24)	-	12 (0.47)	165 (6.50)	45 (1.77)	-	9 (0.35)
09ASB	145 (5.71)	110 ⁰ _{-0.035} (4.33 - 0.0014)	130 (5.12)	6 (0.24)	6 (0.24)	-	12 (0.47)	165 (6.50)	45 (1.77)	-	9 (0.35)
12ASB	200 (7.87)	114.3 ⁰ _{-0.025} (4.50 - 0.0010)	180 (7.09)	3.2 (0.13)	3 (0.12)	0.5 (0.0197)	18 (0.71)	230 (9.06)	76 (2.99)	62 (2.44)	13.5 (0.53)
20ASB	200 (7.87)	114.3 ⁰ _{-0.025} (4.50 - 0.0010)	180 (7.09)	3.2 (0.13)	3 (0.12)	0.5 (0.0197)	18 (0.71)	230 (9.06)	76 (2.99)	62 (2.44)	13.5 (0.53)
30ASB	200 (7.87)	114.3 ⁰ _{-0.025} (4.50 - 0.0010)	180 (7.09)	3.2 (0.13)	3 (0.12)	0.5 (0.0197)	18 (0.71)	230 (9.06)	76 (2.99)	62 (2.44)	13.5 (0.53)
44ASB	200 (7.87)	114.3 ⁰ _{-0.025} (4.50 - 0.0010)	180 (7.09)	3.2 (0.13)	3 (0.12)	0.5 (0.0197)	18 (0.71)	230 (9.06)	76 (2.99)	62 (2.44)	13.5 (0.53)
60ASB	200 (7.87)	114.3 ⁰ _{-0.025} (4.50 - 0.0010)	180 (7.09)	3.2 (0.13)	3 (0.12)	0.5 (0.0197)	18 (0.71)	230 (9.06)	76 (2.99)	62 (2.44)	13.5 (0.53)

in mm (inches)

Type SGMG-	Shaft end dimensions			Approx. mass kg (lb)
	S	S1	Q	
03ASB	$19 \begin{smallmatrix} 0 \\ - 0.013 \\ 0 \end{smallmatrix}$ (0.75 - 0.0005)	30 (1.18)	40 (1.57)	5.9 (13.00)
06ASB	$19 \begin{smallmatrix} 0 \\ - 0.013 \\ 0 \end{smallmatrix}$ (0.75 - 0.0005)	30 (1.18)	40 (1.57)	8.0 (17.63)
09ASB	$22 \begin{smallmatrix} 0 \\ - 0.013 \\ 0 \end{smallmatrix}$ (0.87 - 0.0005)	30 (1.18)	40 (1.57)	10 (22.04)
12ASB	$35 \begin{smallmatrix} + 0.01 \\ 0 \\ + 0.0004 \\ 0 \end{smallmatrix}$ (1.38)	45 (1.77)	76 (2.99)	14 (30.86)
20ASB	$35 \begin{smallmatrix} + 0.01 \\ 0 \\ + 0.0004 \\ 0 \end{smallmatrix}$ (1.38)	45 (1.77)	76 (2.99)	18.5 (40.77)
30ASB	$35 \begin{smallmatrix} + 0.01 \\ 0 \\ + 0.0004 \\ 0 \end{smallmatrix}$ (1.38)	45 (1.77)	76 (2.99)	24 (52.90)
44ASB	$42 \begin{smallmatrix} 0 \\ - 0.016 \\ 0 \end{smallmatrix}$ (1.65 - 0.0006)	45 (1.77)	110 (4.33)	30 (66.12)
60ASB	$42 \begin{smallmatrix} 0 \\ - 0.016 \\ 0 \end{smallmatrix}$ (1.65 - 0.0006)	45 (1.77)	110 (4.33)	40 (88.16)

Note 1) Absolute encoder (15bit : 8192 P/R) is used as a detector.

2) SGMG-03ASB to -30ASB do not contain eyebolts.

上正科技有限公司
 購買、維修 此手冊零組件
 電話: 037-466333
 Email: service@repairtw.com
 Line id: @zzzz
 www.repairtw.com

• Connector Wiring on Detector Side

Receptacle: MS3102A20-29P

Plug (To be prepared by customer) (L type): MS3108B20-29S or
(Straight type) MS3106B20-29S

Cable Clamp: (To be prepared by customer) MS3057-12A

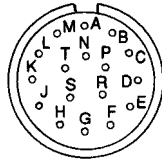

Encoder Wiring Specifications

A	A channel output	K	
B	/A channel output	L	
C	B channel output	M	
D	/B channel output	N	
E	Z (C) channel output	P	
F	/Z (C) channel output	R	Reset
G	0V	S	0V (battery)
H	+5V DC	T	3.6V (battery)
J	FG (Frame Ground)		

Note 1) Terminals K to P are not used.

2) Receptacle, plug and cable clamp are common regardless of motor capacity.

• Connector Wiring on Motor Side

Motor Wiring Specifications



A	Phase U
B	Phase V
C	Phase W
D	Ground terminal

Note Receptacle, plug and cable clamp differ depending on the capacity. Refer to 6) Connectors on Detector and Motor Sides (page 392).

Absolute encoder (15bit : 8192 P/R, 12 bit : 1024 P/R), with brake

- 0.3 to 3.0kW

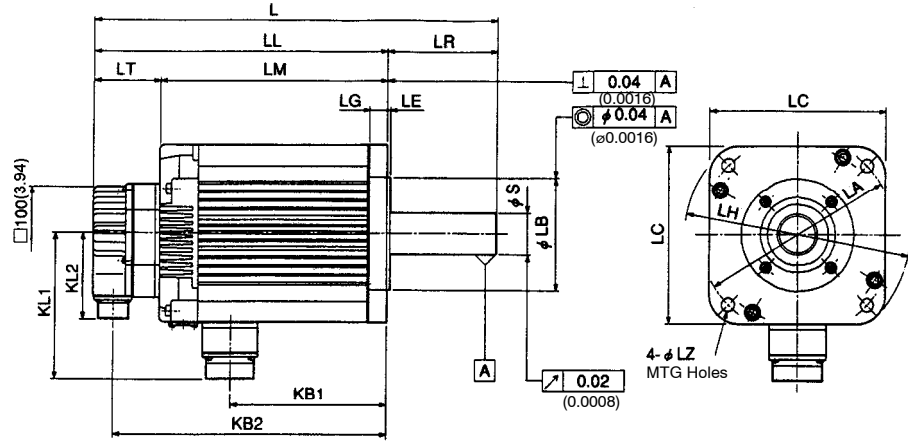

Detailed View of Shaft End for SGMG-03ASBAB to -09ASBAB

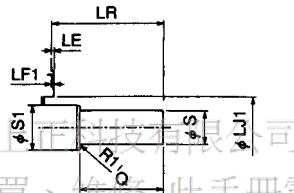

Detailed View of Shaft End for SGMG-12ASBAB to -30ASBAB
Email: service@repairtw.com

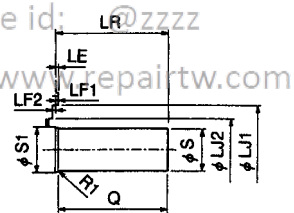

5

購買、維修 此手冊零組件
電話： 037-466333
Email: service@repairtw.com

Line id: LR@zzzz
www.repairtw.com

in mm (inches)

Type SGMG-	Flange dimensions										
	LA	LB	LC	LE	LF1	LF2	LG	LH	LJ1	LJ2	LZ
03ASBAB	145 (5.71)	110 ⁰ _{-0.035} (4.33 ⁰ _{-0.0014})	130 (5.12)	6 (0.24)	6 (0.24)	-	12 (0.47)	165 (6.50)	45 (1.77)	-	9 (0.35)
06ASBAB	145 (5.71)	110 ⁰ _{-0.035} (4.33 ⁰ _{-0.0014})	130 (5.12)	6 (0.24)	6 (0.24)	-	12 (0.47)	165 (6.50)	45 (1.77)	-	9 (0.35)
09ASBAB	145 (5.71)	110 ⁰ _{-0.035} (4.33 ⁰ _{-0.0014})	130 (5.12)	6 (0.24)	6 (0.24)	-	12 (0.47)	165 (6.50)	45 (1.77)	-	9 (0.35)
12ASBAB	200 (7.87)	114.3 ⁰ _{-0.025} (4.50 ⁰ _{-0.0010})	180 (7.09)	3.2 (0.13)	3 (0.12)	0.5 (0.0197)	18 (0.71)	230 (9.06)	76 (2.99)	62 (2.44)	13.5 (0.53)
20ASBAB	200 (7.87)	114.3 ⁰ _{-0.025} (4.50 ⁰ _{-0.0010})	180 (7.09)	3.2 (0.13)	3 (0.12)	0.5 (0.0197)	18 (0.71)	230 (9.06)	76 (2.99)	62 (2.44)	13.5 (0.53)
30ASBAB	200 (7.87)	114.3 ⁰ _{-0.025} (4.50 ⁰ _{-0.0010})	180 (7.09)	3.2 (0.13)	3 (0.12)	0.5 (0.0197)	18 (0.71)	230 (9.06)	76 (2.99)	62 (2.44)	13.5 (0.53)

上正科技有限公司

購買、維修 此手冊零組件

電話： 037-466333

Email: service@repairtw.com

Line id: @zzzz

www.repairtw.com

USING THE DIGITAL OPERATOR

5.4.1 Servomotor Dimensional Drawings cont.

in mm (inches)

Type SGMG-	Shaft end dimensions			Approx. mass kg (lb)
	S	S1	Q	
03ASBAB	$19 \begin{smallmatrix} 0 \\ - 0.013 \\ 0 \end{smallmatrix}$ (0.75 - 0.0005)	30 (1.18)	40 (1.57)	7.9 (17.41)
06ASBAB	$19 \begin{smallmatrix} 0 \\ - 0.013 \\ 0 \end{smallmatrix}$ (0.75 - 0.0005)	30 (1.18)	40 (1.57)	10 (22.04)
09ASBAB	$22 \begin{smallmatrix} 0 \\ - 0.013 \\ 0 \end{smallmatrix}$ (0.87 - 0.0005)	30 (1.18)	40 (1.57)	12 (26.45)
12ASBAB	$35 \begin{smallmatrix} + 0.01 \\ 0 \\ 0 \end{smallmatrix}$ (1.38 + 0.0004)	45 (1.77)	76 (2.99)	19.5 (42.98)
20ASBAB	$35 \begin{smallmatrix} + 0.01 \\ 0 \\ 0 \end{smallmatrix}$ (1.38 + 0.0004)	45 (1.77)	76 (2.99)	23.5 (51.79)
30ASBAB	$35 \begin{smallmatrix} + 0.01 \\ 0 \\ 0 \end{smallmatrix}$ (1.38 + 0.0004)	45 (1.77)	76 (2.99)	29 (63.92)

5

Note Absolute encoder (15bit : 8192 P/R) is used as a detector.

• Connector Wiring on Motor Side 037-466333

上正科技有限公司
 購買、維修 此手冊零組件
 電話 037-466333
 Email: service@repairtw.com
 Motor Wiring Specifications
 @zzzz
 www.repairtw.com



A	Phase U	E	Brake terminal
B	Phase V	F	Brake terminal
C	Phase W	G	-
D	Frame ground (FG)		

• 4.4 to 6.0kW

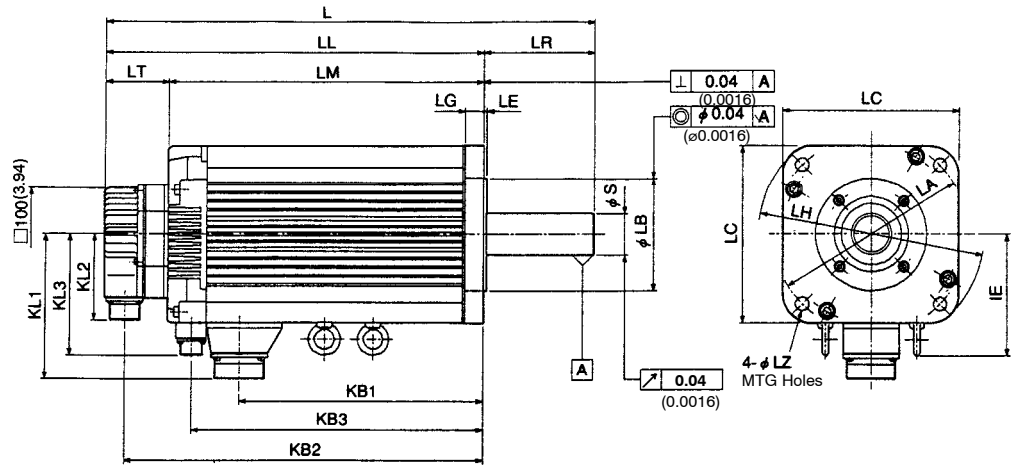

Detailed View of Shaft End

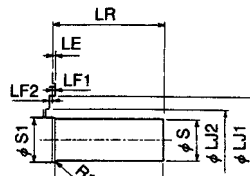

上海科技有限公司

購買、維修 此手冊零組件

電話： 037-466333

Email: service@repairtw.com

in mm (inches)

Type SGMG-	L	LL	LM	LR	LT	KB1	KB2	KB3	IE	KL1	KL2	KL3
44ASBAB	438 (17.24)	325 (12.80)	264 (10.39)	113 (4.45)	61 (2.40)	174 (6.85)	304 (11.97)	231 (9.09)	125 (4.92)	150 (5.91)	88 (3.46)	123 (4.84)
60ASBAB	512 (20.16)	399 (15.71)	338 (13.31)	113 (4.45)	61 (2.40)	248 (9.76)	378 (14.88)	305 (12.01)	125 (4.92)	150 (5.91)	88 (3.46)	123 (4.84)

in mm (inches)

Type SGMG-	Flange dimensions										
	LA	LB	LC	LE	LF1	LF2	LG	LH	LJ1	LJ2	LZ
44ASBAB	200 (7.87)	114.3 ⁰ _{-0.025} (4.50 ⁰ _{-0.0010})	180 (7.09)	3.2 (0.13)	3 (0.12)	0.5 (0.0197)	18 (0.71)	230 (9.06)	76 (2.99)	62 (2.44)	13.5 (0.53)
60ASBAB	200 (7.87)	114.3 ⁰ _{-0.025} (4.50 ⁰ _{-0.0010})	180 (7.09)	3.2 (0.13)	3 (0.12)	0.5 (0.0197)	18 (0.71)	230 (9.06)	76 (2.99)	62 (2.44)	13.5 (0.53)

USING THE DIGITAL OPERATOR

5.4.1 Servomotor Dimensional Drawings cont.

in mm (inches)

Type SGMG-	Shaft end dimensions			Approx. mass kg (lb)
	S	S1	Q	
44ASBAB	$42 \begin{smallmatrix} 0 \\ - 0.016 \\ 0 \\ (1.65 - 0.0006) \end{smallmatrix}$	45 (1.77)	110 (4.33)	36 (79.34)
60ASBAB	$42 \begin{smallmatrix} 0 \\ - 0.016 \\ 0 \\ (1.65 - 0.0006) \end{smallmatrix}$	45 (1.77)	110 (4.33)	50 (110.20)

Note Absolute encoder (15bit : 8192 P/R) is used as a detector.

- Connector Wiring on Brake and Motor Sides



A	Brake terminal
B	Brake terminal
C	

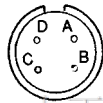

A	Phase U
B	Phase V
C	Phase W
D	Frame ground (FG)

5

上正科技有限公司

購買、維修 此手冊零組件

電話： 037-466333

Email: service@repairtw.com

Line id: @zzzz

www.repairtw.com

Standard backlash gear (1000 min⁻¹), without brake

- Foot-mounted type

Grease-lubrication type servomotors

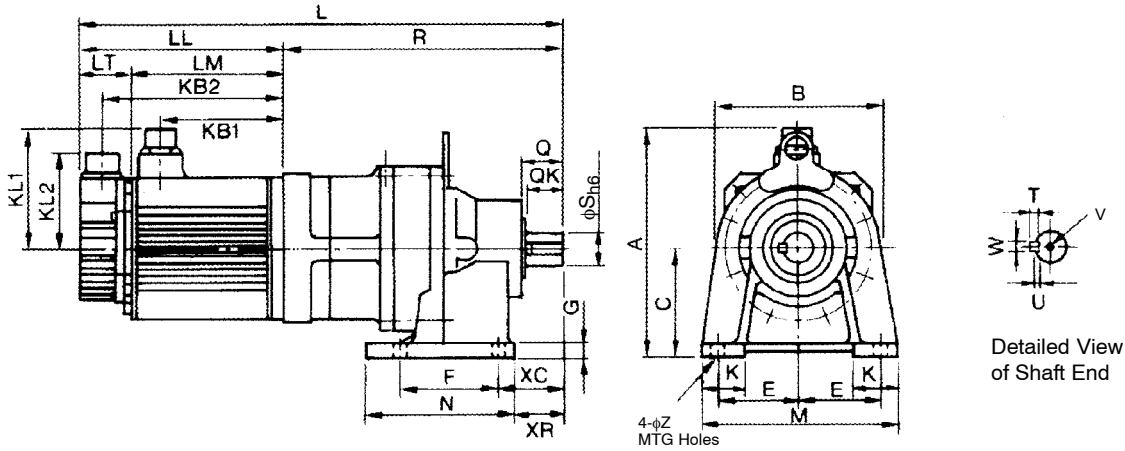

in mm (inches)

Motor type SGMG-	Gear type	Gear ratio	L	LL	LM	LT	KB 1	KB 2	KL1	KL2	R	A	B	C	Shaft center allowable radial load N	Approx. mass kg (lb)
03A2BSAR	CNHX-4095	1/6	380 (15.0)	138 (5.43)	92 (3.62)	46 (1.81)	65 (2.56)	117 (4.61)	109 (4.29)	88 (3.46)	242 (9.53)	209 (8.23)	152 (5.98)	100 ⁰ _{-0.5} (3.94 ⁰ _{-0.020})	2360	20.5 (45.2)
03A2BSBR	CNHX-4095	1/11	380 (15.0)	138 (5.43)	92 (3.62)	46 (1.81)	65 (2.56)	117 (4.61)	109 (4.29)	88 (3.46)	242 (9.53)	209 (8.23)	152 (5.98)	100 ⁰ _{-0.5} (3.94 ⁰ _{-0.020})	2890	20.5 (45.2)
03A2BSCR	CNHX-4105	1/21	394 (15.5)	138 (5.43)	92 (3.62)	46 (1.81)	65 (2.56)	117 (4.61)	109 (4.29)	88 (3.46)	256 (10.1)	209 (8.23)	152 (5.98)	100 ⁰ _{-0.5} (3.94 ⁰ _{-0.020})	5390	22.5 (49.6)
03A2BS7R	CNHX-4105	1/29	394 (15.5)	138 (5.43)	92 (3.62)	46 (1.81)	65 (2.56)	117 (4.61)	109 (4.29)	88 (3.46)	256 (10.1)	209 (8.23)	152 (5.98)	100 ⁰ _{-0.5} (3.94 ⁰ _{-0.020})	5390	22.5 (49.6)
06A2BSAR	CNHX-4105	1/6	417 (16.4)	161 (6.34)	115 (4.53)	46 (1.81)	88 (3.46)	140 (5.51)	109 (4.29)	88 (3.46)	256 (10.1)	209 (8.23)	152 (5.98)	100 ⁰ _{-0.5} (3.94 ⁰ _{-0.020})	3720	24.6 (54.2)
06A2BSBR	CNHX-4105	1/11	417 (16.4)	161 (6.34)	115 (4.53)	46 (1.81)	88 (3.46)	140 (5.51)	109 (4.29)	88 (3.46)	256 (10.1)	209 (8.23)	152 (5.98)	100 ⁰ _{-0.5} (3.94 ⁰ _{-0.020})	4550	24.6 (54.2)
06A2BSCR	CNHX-4115	1/21	449 (17.7)	161 (6.34)	115 (4.53)	46 (1.81)	88 (3.46)	140 (5.51)	109 (4.29)	88 (3.46)	288 (11.3)	257 (10.1)	204 (8.03)	120 ⁰ _{-0.5} (4.72 ⁰ _{-0.020})	7070	34.6 (76.3)
06A2BS7R	CNHX-4115	1/29	449 (17.7)	161 (6.34)	115 (4.53)	46 (1.81)	88 (3.46)	140 (5.51)	109 (4.29)	88 (3.46)	288 (11.3)	257 (10.1)	204 (8.03)	120 ⁰ _{-0.5} (4.72 ⁰ _{-0.020})	7860	34.6 (76.3)
09A2BSAR	CNHX-4105	1/6	441 (17.4)	185 (7.28)	139 (5.47)	46 (1.81)	112 (4.41)	164 (6.46)	109 (4.29)	88 (3.46)	256 (10.1)	209 (8.23)	152 (5.98)	100 ⁰ _{-0.5} (3.94 ⁰ _{-0.020})	3720	26.6 (58.6)
09A2BSBR	CNHX-4105	1/11	441 (17.4)	185 (7.28)	139 (5.47)	46 (1.81)	112 (4.41)	164 (6.46)	109 (4.29)	88 (3.46)	256 (10.1)	209 (8.23)	152 (5.98)	100 ⁰ _{-0.5} (3.94 ⁰ _{-0.020})	4550	26.6 (58.6)

USING THE DIGITAL OPERATOR

5.4.1 Servomotor Dimensional Drawings cont.

Motor type SGMG-	Gear type	Gear ratio	L	LL	LM	LT	KB 1	KB 2	KL1	KL2	R	A	B	C	Shaft center allowable radial load N	Approx. mass kg (lb)
09A2BSCR	CNHX-4115	1/21	473 (18.6)	185 (7.28)	139 (5.47)	46 (1.81)	112 (4.41)	164 (6.46)	109 (4.29)	88 (3.46)	288 (11.3)	257 (10.1)	204 (8.03)	120 ⁰ _{-0.5} (4.72 ⁰ _{-0.020})	7070	36.6 (80.7)
09A2BS7R	CNHX-4115	1/29	473 (18.6)	185 (7.28)	139 (5.47)	46 (1.81)	112 (4.41)	164 (6.46)	109 (4.29)	88 (3.46)	288 (11.3)	257 (10.1)	204 (8.03)	120 ⁰ _{-0.5} (4.72 ⁰ _{-0.020})	7860	36.6 (80.7)
12A2BSAR	CNHX-4115	1/6	477 (18.8)	166 (6.54)	119 (4.69)	47 (1.85)	89 (3.50)	145 (5.71)	140 (5.51)	88 (3.46)	311 (12.2)	260 (10.2)	204 (8.03)	120 ⁰ _{-0.5} (4.72 ⁰ _{-0.020})	4660	43 (94.8)
12A2BSBR	CNHX-4115	1/11	477 (18.8)	166 (6.54)	119 (4.69)	47 (1.85)	89 (3.50)	145 (5.71)	140 (5.51)	88 (3.46)	311 (12.2)	260 (10.2)	204 (8.03)	120 ⁰ _{-0.5} (4.72 ⁰ _{-0.020})	5700	43 (94.8)
12A2BSCR	CNHX-4130	1/21	536 (21.1)	166 (6.54)	119 (4.69)	47 (1.85)	89 (3.50)	145 (5.71)	140 (5.51)	88 (3.46)	370 (14.6)	300 (11.8)	246 (9.69)	150 ⁰ _{-0.5} (5.91 ⁰ _{-0.020})	10180	67 (147.7)
12A2BS7R	CNHX-4135	1/29	536 (21.1)	166 (6.54)	119 (4.69)	47 (1.85)	89 (3.50)	145 (5.71)	140 (5.51)	88 (3.46)	370 (14.6)	300 (11.8)	246 (9.69)	150 ⁰ _{-0.5} (5.91 ⁰ _{-0.020})	11320	67 (147.7)
20A2BSAR	CNHX-4115	1/6	503 (19.8)	192 (7.56)	145 (5.71)	47 (1.85)	115 (4.53)	171 (6.73)	140 (5.51)	88 (3.46)	311 (12.2)	260 (10.2)	204 (8.03)	120 ⁰ _{-0.5} (4.72 ⁰ _{-0.020})	4660	47 (103.6)
20A2BSBR	CNHX-4115	1/11	503 (19.8)	192 (7.56)	145 (5.71)	47 (1.85)	115 (4.53)	171 (6.73)	140 (5.51)	88 (3.46)	311 (12.2)	260 (10.2)	204 (8.03)	120 ⁰ _{-0.5} (4.72 ⁰ _{-0.020})	5700	47 (103.6)
20A2BSCR	CNHX-4145	1/21	582 (22.9)	192 (7.56)	145 (5.71)	47 (1.85)	115 (4.53)	171 (6.73)	140 (5.51)	88 (3.46)	390 (15.4)	300 (11.8)	246 (9.69)	150 ⁰ _{-0.5} (5.91 ⁰ _{-0.020})	13040	72 (158.7)
30A2BSAR	CHHX-4130	1/6	596 (23.5)	226 (8.90)	179 (7.05)	47 (1.85)	149 (5.87)	205 (8.07)	140 (5.51)	88 (3.46)	370 (14.6)	300 (11.8)	246 (9.69)	150 ⁰ _{-0.5} (5.91 ⁰ _{-0.020})	6740	76 (167.5)
30A2BSBR	CHHX-4135	1/11	596 (23.5)	226 (8.90)	179 (7.05)	47 (1.85)	149 (5.87)	205 (8.07)	140 (5.51)	88 (3.46)	370 (14.6)	300 (11.8)	246 (9.69)	150 ⁰ _{-0.5} (5.91 ⁰ _{-0.020})	8240	76 (167.5)
44A2BSAR	CHHX-4135	1/6	664 (26.1)	260 (10.2)	213 (8.39)	47 (1.85)	174 (6.85)	239 (9.41)	150 (5.91)	88 (3.46)	404 (15.9)	300 (11.8)	246 (9.69)	150 ⁰ _{-0.5} (5.91 ⁰ _{-0.020})	6740	88 (194.0)
44A2BSBR	CHHX-4145	1/11	684 (26.9)	260 (10.2)	213 (8.39)	47 (1.85)	174 (6.85)	239 (9.41)	150 (5.91)	88 (3.46)	424 (16.7)	300 (11.8)	246 (9.69)	150 ⁰ _{-0.5} (5.91 ⁰ _{-0.020})	10740	89 (196.2)

in mm (inches)

Motor type SGMG-	Foot dimensions									Shaft end dimensions						
	E	F	G	K	M	N	XR	XC	Z	Q	QK	S	T	U	W	V
03A2BSAR	75 (2.95)	90 (3.54)	12 (0.47)	40 (1.57)	180 (7.09)	130 (5.12)	45 (1.77)	60 (2.36)	11 (0.43)	35 (1.38)	32 (1.26)	φ28 ⁰ _{-0.013} (φ1.10 ⁰ _{-0.0005})	7 (0.28)	4 (0.16)	8 (0.31)	M8 screw, depth 19
03A2BSBR	75 (2.95)	90 (3.54)	12 (0.47)	40 (1.57)	180 (7.09)	130 (5.12)	45 (1.77)	60 (2.36)	11 (0.43)	35 (1.38)	32 (1.26)	φ28 ⁰ _{-0.013} (φ1.10 ⁰ _{-0.0005})	7 (0.28)	4 (0.16)	8 (0.31)	M8 screw, depth 19
03A2BSCR	75 (2.95)	90 (3.54)	12 (0.47)	40 (1.57)	180 (7.09)	135 (5.31)	45 (1.77)	60 (2.36)	11 (0.43)	35 (1.38)	32 (1.26)	φ28 ⁰ _{-0.013} (φ1.10 ⁰ _{-0.0005})	7 (0.28)	4 (0.16)	8 (0.31)	M8 screw, depth 19
03A2BS7R	75 (2.95)	90 (3.54)	12 (0.47)	40 (1.57)	180 (7.09)	135 (5.31)	45 (1.77)	60 (2.36)	11 (0.43)	35 (1.38)	32 (1.26)	φ28 ⁰ _{-0.013} (φ1.10 ⁰ _{-0.0005})	7 (0.28)	4 (0.16)	8 (0.31)	M8 screw, depth 19

Motor type SGMG-	Foot dimensions									Shaft end dimensions						
	E	F	G	K	M	N	XR	XC	Z	Q	QK	S	T	U	W	V
06A2BSAR	75 (2.95)	90 (3.54)	12 (0.47)	40 (1.57)	180 (7.09)	135 (5.31)	45 (1.77)	60 (2.36)	11 (0.43)	35 (1.38)	32 (1.26)	$\phi 28 \begin{matrix} 0 \\ -0.013 \\ 0 \\ \phi 1.10 \\ 0 \\ -0.0005 \end{matrix}$	7 (0.28)	4 (0.16)	8 (0.31)	M8 screw, depth 19
06A2BSBR	75 (2.95)	90 (3.54)	12 (0.47)	40 (1.57)	180 (7.09)	135 (5.31)	45 (1.77)	60 (2.36)	11 (0.43)	35 (1.38)	32 (1.26)	$\phi 28 \begin{matrix} 0 \\ -0.013 \\ 0 \\ \phi 1.10 \\ 0 \\ -0.0005 \end{matrix}$	7 (0.28)	4 (0.16)	8 (0.31)	M8 screw, depth 19
06A2BSCR	95 (3.74)	115 (4.53)	15 (0.59)	55 (2.17)	230 (9.06)	155 (6.10)	62 (2.44)	82 (3.23)	14 (0.55)	55 (2.17)	50 (1.97)	$\phi 38 \begin{matrix} 0 \\ -0.016 \\ 0 \\ \phi 1.50 \\ 0 \\ -0.0006 \end{matrix}$	8 (0.31)	5 (0.20)	10 (0.39)	M10 screw, depth 22
06A2BS7R	95 (3.74)	115 (4.53)	15 (0.59)	55 (2.17)	230 (9.06)	155 (6.10)	62 (2.44)	82 (3.23)	14 (0.55)	55 (2.17)	50 (1.97)	$\phi 38 \begin{matrix} 0 \\ -0.016 \\ 0 \\ \phi 1.50 \\ 0 \\ -0.0006 \end{matrix}$	8 (0.31)	5 (0.20)	10 (0.39)	M10 screw, depth 22
09A2BSAR	75 (2.95)	90 (3.54)	12 (0.47)	40 (1.57)	180 (7.09)	135 (5.31)	45 (1.77)	60 (2.36)	11 (0.43)	35 (1.38)	32 (1.26)	$\phi 28 \begin{matrix} 0 \\ -0.013 \\ 0 \\ \phi 1.10 \\ 0 \\ -0.0005 \end{matrix}$	7 (0.28)	4 (0.16)	8 (0.31)	M8 screw, depth 19
09A2BSBR	75 (2.95)	90 (3.54)	12 (0.47)	40 (1.57)	180 (7.09)	135 (5.31)	45 (1.77)	60 (2.36)	11 (0.43)	35 (1.38)	32 (1.26)	$\phi 28 \begin{matrix} 0 \\ -0.013 \\ 0 \\ \phi 1.10 \\ 0 \\ -0.0005 \end{matrix}$	7 (0.28)	4 (0.16)	8 (0.31)	M8 screw, depth 19
09A2BSCR	95 (3.74)	115 (4.53)	15 (0.59)	55 (2.17)	230 (9.06)	155 (6.10)	62 (2.44)	82 (3.23)	14 (0.55)	55 (2.17)	50 (1.97)	$\phi 38 \begin{matrix} 0 \\ -0.016 \\ 0 \\ \phi 1.50 \\ 0 \\ -0.0006 \end{matrix}$	8 (0.31)	5 (0.20)	10 (0.39)	M10 screw, depth 22
09A2BS7R	95 (3.74)	115 (4.53)	15 (0.59)	55 (2.17)	230 (9.06)	155 (6.10)	62 (2.44)	82 (3.23)	14 (0.55)	55 (2.17)	50 (1.97)	$\phi 38 \begin{matrix} 0 \\ -0.016 \\ 0 \\ \phi 1.50 \\ 0 \\ -0.0006 \end{matrix}$	8 (0.31)	5 (0.20)	10 (0.39)	M10 screw, depth 22
12A2BSAR	95 (3.74)	115 (4.53)	15 (0.59)	55 (2.17)	230 (9.06)	155 (6.10)	62 (2.44)	82 (3.23)	14 (0.55)	55 (2.17)	50 (1.97)	$\phi 38 \begin{matrix} 0 \\ -0.016 \\ 0 \\ \phi 1.50 \\ 0 \\ -0.0006 \end{matrix}$	8 (0.31)	5 (0.20)	10 (0.39)	M10 screw, depth 22
12A2BSBR	95 (3.74)	115 (4.53)	15 (0.59)	55 (2.17)	230 (9.06)	155 (6.10)	62 (2.44)	82 (3.23)	14 (0.55)	55 (2.17)	50 (1.97)	$\phi 38 \begin{matrix} 0 \\ -0.016 \\ 0 \\ \phi 1.50 \\ 0 \\ -0.0006 \end{matrix}$	8 (0.31)	5 (0.20)	10 (0.39)	M10 screw, depth 22
12A2BSCR	145 (5.71)	145 (5.71)	22 (0.87)	65 (2.56)	330 (13.0)	195 (7.68)	75 (2.95)	100 (3.94)	18 (0.71)	70 (2.76)	56 (2.20)	$\phi 50 \begin{matrix} 0 \\ -0.016 \\ 0 \\ \phi 1.97 \\ 0 \\ -0.0006 \end{matrix}$	9 (0.35)	5.5 (0.22)	14 (0.55)	M10 screw, depth 18
12A2BS7R	145 (5.71)	145 (5.71)	22 (0.87)	65 (2.56)	330 (13.0)	195 (7.68)	75 (2.95)	100 (3.94)	18 (0.71)	70 (2.76)	56 (2.20)	$\phi 50 \begin{matrix} 0 \\ -0.016 \\ 0 \\ \phi 1.97 \\ 0 \\ -0.0006 \end{matrix}$	9 (0.35)	5.5 (0.22)	14 (0.55)	M10 screw, depth 18
20A2BSAR	95 (3.74)	115 (4.53)	15 (0.59)	55 (2.17)	230 (9.06)	155 (6.10)	62 (2.44)	82 (3.23)	14 (0.55)	55 (2.17)	50 (1.97)	$\phi 38 \begin{matrix} 0 \\ -0.016 \\ 0 \\ \phi 1.50 \\ 0 \\ -0.0006 \end{matrix}$	8 (0.31)	5 (0.20)	10 (0.39)	M10 screw, depth 22
20A2BSBR	95 (3.74)	115 (4.53)	15 (0.59)	55 (2.17)	230 (9.06)	155 (6.10)	62 (2.44)	82 (3.23)	14 (0.55)	55 (2.17)	50 (1.97)	$\phi 38 \begin{matrix} 0 \\ -0.016 \\ 0 \\ \phi 1.50 \\ 0 \\ -0.0006 \end{matrix}$	8 (0.31)	5 (0.20)	10 (0.39)	M10 screw, depth 22
20A2BSCR	145 (5.71)	145 (5.71)	22 (0.87)	65 (2.56)	330 (13.0)	195 (7.68)	95 (3.74)	120 (4.72)	18 (0.71)	90 (3.54)	80 (3.15)	$\phi 50 \begin{matrix} 0 \\ -0.016 \\ 0 \\ \phi 1.97 \\ 0 \\ -0.0006 \end{matrix}$	9 (0.35)	5.5 (0.22)	14 (0.55)	M10 screw, depth 18
30A2BSAR	145 (5.71)	145 (5.71)	22 (0.87)	65 (2.56)	330 (13.0)	195 (7.68)	75 (2.95)	100 (3.94)	18 (0.71)	70 (2.76)	56 (2.20)	$\phi 50 \begin{matrix} 0 \\ -0.016 \\ 0 \\ \phi 1.97 \\ 0 \\ -0.0006 \end{matrix}$	9 (0.35)	5.5 (0.22)	14 (0.55)	M10 screw, depth 18
30A2BSBR	145 (5.71)	145 (5.71)	22 (0.87)	65 (2.56)	330 (13.0)	195 (7.68)	75 (2.95)	100 (3.94)	18 (0.71)	70 (2.76)	56 (2.20)	$\phi 50 \begin{matrix} 0 \\ -0.016 \\ 0 \\ \phi 1.97 \\ 0 \\ -0.0006 \end{matrix}$	9 (0.35)	5.5 (0.22)	14 (0.55)	M10 screw, depth 18
44A2BSAR	145 (5.71)	145 (5.71)	22 (0.87)	65 (2.56)	330 (13.0)	195 (7.68)	75 (2.95)	100 (3.94)	18 (0.71)	70 (2.76)	56 (2.20)	$\phi 50 \begin{matrix} 0 \\ -0.016 \\ 0 \\ \phi 1.97 \\ 0 \\ -0.0006 \end{matrix}$	9 (0.35)	5.5 (0.22)	14 (0.55)	M10 screw, depth 18
44A2BSBR	145 (5.71)	145 (5.71)	22 (0.87)	65 (2.56)	330 (13.0)	195 (7.68)	95 (3.74)	120 (4.72)	18 (0.71)	90 (3.54)	80 (3.15)	$\phi 50 \begin{matrix} 0 \\ -0.016 \\ 0 \\ \phi 1.97 \\ 0 \\ -0.0006 \end{matrix}$	9 (0.35)	5.5 (0.22)	14 (0.55)	M10 screw, depth 18

5

Oil-lubrication type servomotors

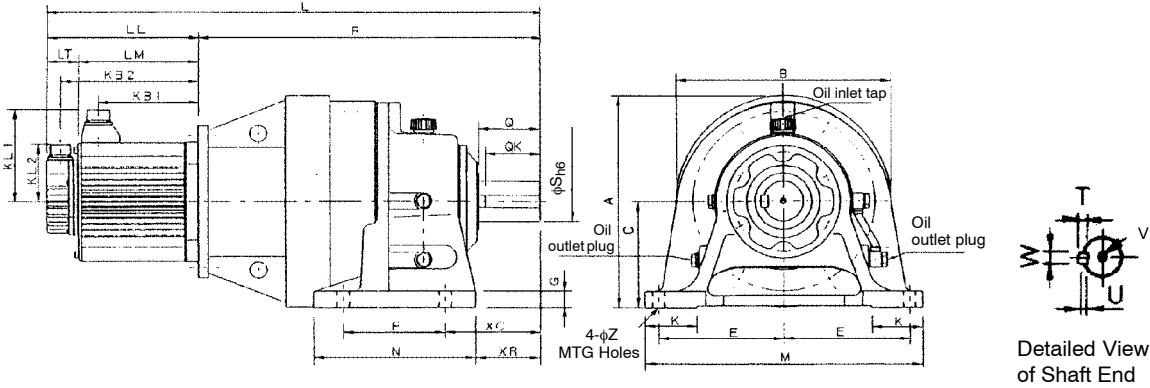

in mm (inches)

Motor type SGMG-	Gear type	Gear ratio	L	LL	LM	LT	KB1	KB2	KL1	KL2	R	A	B	C	Shaft center allowable radial load N	Approx. mass kg (lb)
20A2BS7R	CHHJ-4160	1/29	687 (27.1)	192 (7.56)	145 (5.71)	47 (1.85)	115 (4.53)	171 (6.73)	140 (5.51)	88 (3.46)	495 (19.5)	319 (12.6)	318 (12.5)	160 ⁰ _{-0.5} (6.30 ⁰ _{-0.020})	18520	126 (277.8)
30A2BSCR	CHHJ-4160	1/21	721 (28.4)	226 (8.90)	179 (7.05)	47 (1.85)	149 (5.87)	205 (8.07)	140 (5.51)	88 (3.46)	495 (19.5)	319 (12.6)	318 (12.5)	160 ⁰ _{-0.5} (6.30 ⁰ _{-0.020})	16740	131 (288.8)
30A2BS7R	CHHJ-4170	1/29	785 (30.9)	226 (8.90)	179 (7.05)	47 (1.85)	149 (5.87)	205 (8.07)	140 (5.51)	88 (3.46)	559 (22.0)	382 (15.0)	363 (14.3)	200 ⁰ _{-0.5} (7.87 ⁰ _{-0.020})	21770	176 (388.0)
44A2BSCR	CHHJ-4170	1/21	853 (33.6)	260 (10.2)	213 (8.39)	47 (1.85)	174 (6.85)	239 (9.41)	150 (5.91)	88 (3.46)	593 (23.4)	382 (15.0)	363 (14.3)	200 ⁰ _{-0.5} (7.87 ⁰ _{-0.020})	19560	191 (421.1)
44A2BS7R	CHHJ-4175	1/29	853 (33.6)	260 (10.2)	213 (8.39)	47 (1.85)	174 (6.85)	239 (9.41)	150 (5.91)	88 (3.46)	593 (23.4)	382 (15.0)	363 (14.3)	200 ⁰ _{-0.5} (7.87 ⁰ _{-0.020})	21790	191 (421.1)
60A2BSBR	CHHJ-4160	1/11	863 (34.0)	334 (13.2)	287 (11.3)	47 (1.85)	248 (9.76)	313 (12.3)	150 (5.91)	88 (3.46)	529 (20.8)	319 (12.6)	318 (12.5)	160 ⁰ _{-0.5} (6.30 ⁰ _{-0.020})	13470	155 (341.7)
60A2BSCR	CHHJ-4175	1/21	927 (36.5)	334 (13.2)	287 (11.3)	47 (1.85)	248 (9.76)	313 (12.3)	150 (5.91)	88 (3.46)	593 (23.4)	382 (15.0)	363 (14.3)	200 ⁰ _{-0.5} (7.87 ⁰ _{-0.020})	19560	201 (443.1)
60A2BS7R	CHHJ-4185	1/29	977 (38.5)	334 (13.2)	287 (11.3)	47 (1.85)	248 (9.76)	313 (12.3)	150 (5.91)	88 (3.46)	643 (25.3)	417 (16.4)	393 (15.5)	220 ⁰ _{-0.5} (8.66 ⁰ _{-0.020})	29200	245 (540.1)

in mm (inches)

Motor type SGMG-	Foot dimensions									Shaft end dimensions						
	E	F	G	K	M	N	XR	XC	Z	Q	QK	S	T	U	W	V
20A2BS7R	185 (7.28)	150 (5.91)	25 (0.98)	75 (2.95)	410 (16.1)	238 (9.37)	95 (3.74)	139 (5.47)	18 (0.71)	90 (3.54)	80 (3.15)	$\phi 60^{0}_{-0.019}$ ($\phi 2.36^{0}_{-0.0007}$)	11 (0.43)	7 (0.28)	18 (0.71)	M10 screw, depth 18
30A2BSCR	185 (7.28)	150 (5.91)	25 (0.98)	75 (2.95)	410 (16.1)	238 (9.37)	95 (3.74)	139 (5.47)	18 (0.71)	90 (3.54)	80 (3.15)	$\phi 60^{0}_{-0.019}$ ($\phi 2.36^{0}_{-0.0007}$)	11 (0.43)	7 (0.28)	18 (0.71)	M10 screw, depth 18
30A2BS7R	190 (7.48)	275 (10.8)	30 (1.18)	80 (3.15)	430 (16.9)	335 (13.2)	95 (3.74)	125 (4.92)	22 (0.87)	90 (3.54)	80 (3.15)	$\phi 70^{0}_{-0.016}$ ($\phi 2.76^{0}_{-0.0006}$)	12 (0.47)	7.5 (0.30)	20 (0.79)	M12 screw, depth 24
44A2BSCR	190 (7.48)	275 (10.8)	30 (1.18)	80 (3.15)	430 (16.9)	335 (13.2)	95 (3.74)	125 (4.92)	22 (0.87)	90 (3.54)	80 (3.15)	$\phi 70^{0}_{-0.016}$ ($\phi 2.76^{0}_{-0.0006}$)	12 (0.47)	7.5 (0.30)	20 (0.79)	M12 screw, depth 24
44A2BS7R	190 (7.48)	275 (10.8)	30 (1.18)	80 (3.15)	430 (16.9)	335 (13.2)	95 (3.74)	125 (4.92)	22 (0.87)	90 (3.54)	80 (3.15)	$\phi 70^{0}_{-0.016}$ ($\phi 2.76^{0}_{-0.0006}$)	12 (0.47)	7.5 (0.30)	20 (0.79)	M12 screw, depth 24
60A2BSBR	185 (7.28)	150 (5.91)	25 (0.98)	75 (2.95)	410 (16.1)	238 (9.37)	95 (3.74)	139 (5.47)	18 (0.71)	90 (3.54)	80 (3.15)	$\phi 60^{0}_{-0.019}$ ($\phi 2.36^{0}_{-0.0007}$)	11 (0.43)	7 (0.28)	18 (0.71)	M10 screw, depth 18
60A2BSCR	190 (7.48)	275 (10.8)	30 (1.18)	80 (3.15)	430 (16.9)	335 (13.2)	95 (3.74)	125 (4.92)	22 (0.87)	90 (3.54)	80 (3.15)	$\phi 70^{0}_{-0.016}$ ($\phi 2.76^{0}_{-0.0006}$)	12 (0.47)	7.5 (0.30)	20 (0.79)	M12 screw, depth 24
60A2BS7R	210 (8.27)	320 (12.6)	30 (1.18)	85 (3.35)	470 (18.5)	380 (15.0)	115 (4.53)	145 (5.71)	22 (0.87)	110 (4.33)	100 (3.94)	$\phi 80^{0}_{-0.016}$ ($\phi 3.15^{0}_{-0.0006}$)	14 (0.55)	9 (0.35)	22 (0.87)	M12 screw, depth 24

上正科技有限公司

購買、維修 此手冊零組件

電話： 037-466333

Email: service@repairtw.com

Line id: @zzzz

www.repairtw.com

• Frange-mounted Type

Grease-lubrication type servomotors

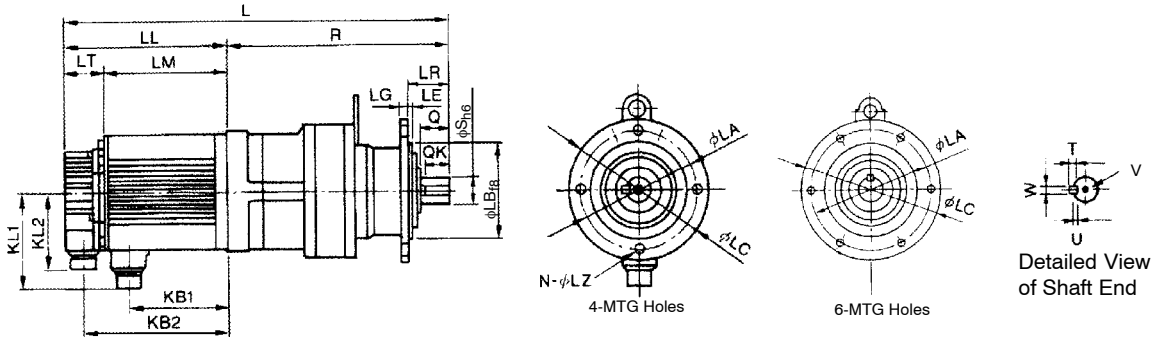

in mm (inches)

Motor type SGMG-	Gear type	Gear ratio	L	LL	LM	LT	KB1	KB2	KL1	KL2	R	Shaft center allowable radial load N	Approx. mass kg (lb)
03A2BTAR	CNVX-4095	1/6	380 (15.0)	138 (5.43)	92 (3.62)	46 (1.81)	65 (2.56)	117 (4.61)	109 (4.29)	88 (3.46)	242 (9.53)	2360	18.5 (40.8)
03A2BTBR	CNVX-4095	1/11	380 (15.0)	138 (5.43)	92 (3.62)	46 (1.81)	65 (2.56)	117 (4.61)	109 (4.29)	88 (3.46)	242 (9.53)	2890	18.5 (40.8)
03A2BTCR	CNVX-4105	1/21	394 (15.5)	138 (5.43)	92 (3.62)	46 (1.81)	65 (2.56)	117 (4.61)	109 (4.29)	88 (3.46)	256 (10.1)	5390	20.5 (45.2)
03A2BT7R	CNVX-4105	1/29	394 (15.5)	138 (5.43)	92 (3.62)	46 (1.81)	65 (2.56)	117 (4.61)	109 (4.29)	88 (3.46)	256 (10.1)	5390	20.5 (45.2)
06A2BTAR	CNVX-4105	1/6	417 (16.4)	161 (6.34)	115 (4.53)	46 (1.81)	88 (3.46)	140 (5.51)	109 (4.29)	88 (3.46)	256 (10.1)	3720	22.6 (49.8)
06A2BTBR	CNVX-4105	1/11	417 (16.4)	161 (6.34)	115 (4.53)	46 (1.81)	88 (3.46)	140 (5.51)	109 (4.29)	88 (3.46)	256 (10.1)	4550	22.6 (49.8)
06A2BTCR	CNVX-4115	1/21	449 (17.7)	161 (6.34)	115 (4.53)	46 (1.81)	88 (3.46)	140 (5.51)	109 (4.29)	88 (3.46)	288 (11.3)	7070	33.6 (74.1)
06A2BT7R	CNVX-4115	1/29	449 (17.7)	161 (6.34)	115 (4.53)	46 (1.81)	88 (3.46)	140 (5.51)	109 (4.29)	88 (3.46)	288 (11.3)	7860	33.6 (74.1)
09A2BTAR	CNVX-4105	1/6	441 (17.4)	185 (7.28)	139 (5.47)	46 (1.81)	112 (4.41)	164 (6.46)	109 (4.29)	88 (3.46)	256 (10.1)	3720	24.6 (54.2)
09A2BTBR	CNVX-4105	1/11	441 (17.4)	185 (7.28)	139 (5.47)	46 (1.81)	112 (4.41)	164 (6.46)	109 (4.29)	88 (3.46)	256 (10.1)	4550	24.6 (54.2)
09A2BTCR	CNVX-4115	1/21	473 (18.6)	185 (7.28)	139 (5.47)	46 (1.81)	112 (4.41)	164 (6.46)	109 (4.29)	88 (3.46)	288 (11.3)	7070	35.6 (78.5)
09A2BT7R	CNVX-4115	1/29	473 (18.6)	185 (7.28)	139 (5.47)	46 (1.81)	112 (4.41)	164 (6.46)	109 (4.29)	88 (3.46)	288 (11.3)	7860	35.6 (78.5)
12A2BTAR	CNVX-4115	1/6	477 (18.8)	166 (6.54)	119 (4.69)	47 (1.85)	89 (3.50)	145 (5.71)	140 (5.51)	88 (3.46)	311 (12.2)	4660	42 (92.6)
12A2BTBR	CNVX-4115	1/11	477 (18.8)	166 (6.54)	119 (4.69)	47 (1.85)	89 (3.50)	145 (5.71)	140 (5.51)	88 (3.46)	311 (12.2)	5700	42 (92.6)
20A2BTAR	CNVX-4115	1/6	503 (19.8)	192 (7.56)	145 (5.71)	47 (1.85)	115 (4.53)	171 (6.73)	140 (5.51)	88 (3.46)	311 (12.2)	4660	46 (101.4)
20A2BTBR	CNVX-4115	1/11	503 (19.8)	192 (7.56)	145 (5.71)	47 (1.85)	115 (4.53)	171 (6.73)	140 (5.51)	88 (3.46)	311 (12.2)	5700	46 (101.4)

in mm (inches)

Motor type SGMG-	Flange dimensions								Shaft end dimensions						
	LA	LB	LC	LE	LG	LR	N	LZ	Q	QK	S	T	U	W	V
03A2BTAR	134 (5.28)	110 ^{-0.036} _{-0.090} (4.33 ^{-0.0014} _{-0.0035})	160 (6.30)	3 (0.12)	9 (0.35)	48 (1.89)	4 (0.16)	11 (0.43)	35 (1.38)	32 (1.26)	φ28 ⁰ _{-0.013} (φ1.10 ⁰ _{-0.0005})	7 (0.28)	4 (0.16)	8 (0.31)	M8 screw, depth 19
03A2BTBR	134 (5.28)	110 ^{-0.036} _{-0.090} (4.33 ^{-0.0014} _{-0.0035})	160 (6.30)	3 (0.12)	9 (0.35)	48 (1.89)	4 (0.16)	11 (0.43)	35 (1.38)	32 (1.26)	φ28 ⁰ _{-0.013} (φ1.10 ⁰ _{-0.0005})	7 (0.28)	4 (0.16)	8 (0.31)	M8 screw, depth 19
03A2BTCR	134 (5.28)	110 ^{-0.036} _{-0.090} (4.33 ^{-0.0014} _{-0.0035})	160 (6.30)	3 (0.12)	9 (0.35)	48 (1.89)	4 (0.16)	11 (0.43)	35 (1.38)	32 (1.26)	φ28 ⁰ _{-0.013} (φ1.10 ⁰ _{-0.0005})	7 (0.28)	4 (0.16)	8 (0.31)	M8 screw, depth 19
03A2BT7R	134 (5.28)	110 ^{-0.036} _{-0.090} (4.33 ^{-0.0014} _{-0.0035})	160 (6.30)	3 (0.12)	9 (0.35)	48 (1.89)	4 (0.16)	11 (0.43)	35 (1.38)	32 (1.26)	φ28 ⁰ _{-0.013} (φ1.10 ⁰ _{-0.0005})	7 (0.28)	4 (0.16)	8 (0.31)	M8 screw, depth 19
06A2BTAR	134 (5.28)	110 ^{-0.036} _{-0.090} (4.33 ^{-0.0014} _{-0.0035})	160 (6.30)	3 (0.12)	9 (0.35)	48 (1.89)	4 (0.16)	11 (0.43)	35 (1.38)	32 (1.26)	φ28 ⁰ _{-0.013} (φ1.10 ⁰ _{-0.0005})	7 (0.28)	4 (0.16)	8 (0.31)	M8 screw, depth 19
06A2BTBR	134 (5.28)	110 ^{-0.036} _{-0.090} (4.33 ^{-0.0014} _{-0.0035})	160 (6.30)	3 (0.12)	9 (0.35)	48 (1.89)	4 (0.16)	11 (0.43)	35 (1.38)	32 (1.26)	φ28 ⁰ _{-0.013} (φ1.10 ⁰ _{-0.0005})	7 (0.28)	4 (0.16)	8 (0.31)	M8 screw, depth 19
06A2BTCR	180 (7.09)	140 ^{-0.043} _{-0.106} (5.51 ^{-0.0017} _{-0.0042})	210 (8.27)	4 (0.16)	13 (0.51)	69 (2.72)	6 (0.24)	11 (0.43)	55 (2.17)	50 (1.97)	φ38 ⁰ _{-0.016} (φ1.50 ⁰ _{-0.0006})	8 (0.31)	5 (0.20)	10 (0.39)	M10 screw, depth 22
06A2BT7R	180 (7.09)	140 ^{-0.043} _{-0.106} (5.51 ^{-0.0017} _{-0.0042})	210 (8.27)	4 (0.16)	13 (0.51)	69 (2.72)	6 (0.24)	11 (0.43)	55 (2.17)	50 (1.97)	φ38 ⁰ _{-0.016} (φ1.50 ⁰ _{-0.0006})	8 (0.31)	5 (0.20)	10 (0.39)	M10 screw, depth 22
09A2BTAR	134 (5.28)	110 ^{-0.036} _{-0.090} (4.33 ^{-0.0014} _{-0.0035})	160 (6.30)	3 (0.12)	9 (0.35)	48 (1.89)	4 (0.16)	11 (0.43)	35 (1.38)	32 (1.26)	φ28 ⁰ _{-0.013} (φ1.10 ⁰ _{-0.0005})	7 (0.28)	4 (0.16)	8 (0.31)	M8 screw, depth 19
09A2BTBR	134 (5.28)	110 ^{-0.036} _{-0.090} (4.33 ^{-0.0014} _{-0.0035})	160 (6.30)	3 (0.12)	9 (0.35)	48 (1.89)	4 (0.16)	11 (0.43)	35 (1.38)	32 (1.26)	φ28 ⁰ _{-0.013} (φ1.10 ⁰ _{-0.0005})	7 (0.28)	4 (0.16)	8 (0.31)	M8 screw, depth 19
09A2BTCR	180 (7.09)	140 ^{-0.043} _{-0.106} (5.51 ^{-0.0017} _{-0.0042})	210 (8.27)	4 (0.16)	13 (0.51)	69 (2.72)	6 (0.24)	11 (0.43)	55 (2.17)	50 (1.97)	φ38 ⁰ _{-0.016} (φ1.50 ⁰ _{-0.0006})	8 (0.31)	5 (0.20)	10 (0.39)	M10 screw, depth 22
09A2BT7R	180 (7.09)	140 ^{-0.043} _{-0.106} (5.51 ^{-0.0017} _{-0.0042})	210 (8.27)	4 (0.16)	13 (0.51)	69 (2.72)	6 (0.24)	11 (0.43)	55 (2.17)	50 (1.97)	φ38 ⁰ _{-0.016} (φ1.50 ⁰ _{-0.0006})	8 (0.31)	5 (0.20)	10 (0.39)	M10 screw, depth 22
12A2BTAR	180 (7.09)	140 ^{-0.043} _{-0.106} (5.51 ^{-0.0017} _{-0.0042})	210 (8.27)	4 (0.16)	13 (0.51)	69 (2.72)	6 (0.24)	11 (0.43)	55 (2.17)	50 (1.97)	φ38 ⁰ _{-0.016} (φ1.50 ⁰ _{-0.0006})	8 (0.31)	5 (0.20)	10 (0.39)	M10 screw, depth 22
12A2BTBR	180 (7.09)	140 ^{-0.043} _{-0.106} (5.51 ^{-0.0017} _{-0.0042})	210 (8.27)	4 (0.16)	13 (0.51)	69 (2.72)	6 (0.24)	11 (0.43)	55 (2.17)	50 (1.97)	φ38 ⁰ _{-0.016} (φ1.50 ⁰ _{-0.0006})	8 (0.31)	5 (0.20)	10 (0.39)	M10 screw, depth 22
20A2BTAR	180 (7.09)	140 ^{-0.043} _{-0.106} (5.51 ^{-0.0017} _{-0.0042})	210 (8.27)	4 (0.16)	13 (0.51)	69 (2.72)	6 (0.24)	11 (0.43)	55 (2.17)	50 (1.97)	φ38 ⁰ _{-0.016} (φ1.50 ⁰ _{-0.0006})	8 (0.31)	5 (0.20)	10 (0.39)	M10 screw, depth 22
20A2BTBR	180 (7.09)	140 ^{-0.043} _{-0.106} (5.51 ^{-0.0017} _{-0.0042})	210 (8.27)	4 (0.16)	13 (0.51)	69 (2.72)	6 (0.24)	11 (0.43)	55 (2.17)	50 (1.97)	φ38 ⁰ _{-0.016} (φ1.50 ⁰ _{-0.0006})	8 (0.31)	5 (0.20)	10 (0.39)	M10 screw, depth 22

Oil-lubrication type small size servomotors

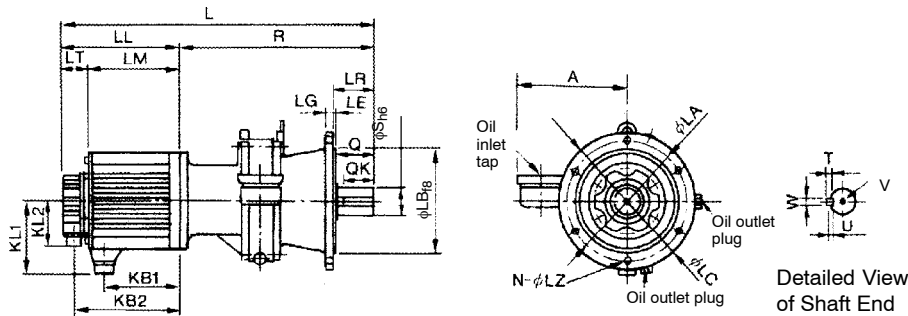

in mm (inches)

Motor type SGMG-	Gear type	Gear ratio	L	LL	LM	LT	KB1	KB2	KL1	KL2	R	A	Shaft center allowable radial load N	Approx. mass kg (lb)
12A2BTCR	CHVX-4130	1/21	536 (21.1)	166 (6.54)	119 (4.69)	47 (1.85)	89 (3.50)	145 (5.71)	140 (5.51)	88 (3.46)	370 (14.6)	209 (8.23)	10180	66 (145.5)
12A2BT7R	CHVX-4135	1/29	536 (21.1)	166 (6.54)	119 (4.69)	47 (1.85)	89 (3.50)	145 (5.71)	140 (5.51)	88 (3.46)	370 (14.6)	209 (8.23)	11320	66 (145.5)
20A2BTCR	CHVX-4145	1/21	582 (22.9)	192 (7.56)	145 (5.71)	47 (1.85)	115 (4.53)	171 (6.73)	140 (5.51)	88 (3.46)	390 (15.4)	209 (8.23)	13040	71 (156.5)
30A2BTAR	CHVX-4130	1/6	596 (23.5)	226 (8.90)	179 (7.05)	47 (1.85)	149 (5.87)	205 (8.07)	140 (5.51)	88 (3.46)	370 (14.6)	209 (8.23)	6740	75 (165.3)
30A2BTBR	CHVX-4135	1/11	596 (23.5)	226 (8.90)	179 (7.05)	47 (1.85)	149 (5.87)	205 (8.07)	140 (5.51)	88 (3.46)	370 (14.6)	209 (8.23)	8240	75 (165.3)
44A2BTAR	CHVX-4135	1/6	664 (26.1)	260 (10.2)	213 (8.39)	47 (1.85)	174 (6.85)	239 (9.41)	150 (5.91)	88 (3.46)	404 (15.9)	209 (8.23)	6740	87 (191.8)
44A2BTBR	CHVX-4145	1/11	684 (26.9)	260 (10.2)	213 (8.39)	47 (1.85)	174 (6.85)	239 (9.41)	150 (5.91)	88 (3.46)	424 (16.7)	209 (8.23)	10740	88 (194.0)

in mm (inches)

Motor type SGMG-	Frange dimensions									Shaft end dimensions					
	LA	LB	LC	LE	LG	LR	N	LZ	Q	QK	S	T	U	W	V
12A2BTCR	230 (9.06)	200 ^{+0.122} _{+0.050} (7.87 ^{+0.0048} _{+0.0020})	260 (10.2)	4 (0.16)	15 (0.59)	76 (2.99)	6 (0.24)	11 (0.43)	70 (2.76)	56 (2.20)	φ50 ⁰ _{-0.016} (φ1.97 ⁰ _{-0.0006})	9 (0.35)	5.5 (0.22)	14 (0.55)	M10 screw, depth 18
12A2BT7R	230 (9.06)	200 ^{+0.122} _{+0.050} (7.87 ^{+0.0048} _{+0.0020})	260 (10.2)	4 (0.16)	15 (0.59)	76 (2.99)	6 (0.24)	11 (0.43)	70 (2.76)	56 (2.20)	φ50 ⁰ _{-0.016} (φ1.97 ⁰ _{-0.0006})	9 (0.35)	5.5 (0.22)	14 (0.55)	M10 screw, depth 18
20A2BTCR	230 (9.06)	200 ^{+0.122} _{+0.050} (7.87 ^{+0.0048} _{+0.0020})	260 (10.2)	4 (0.16)	15 (0.59)	96 (3.78)	6 (0.24)	11 (0.43)	90 (3.54)	80 (3.15)	φ50 ⁰ _{-0.016} (φ1.97 ⁰ _{-0.0006})	9 (0.35)	5.5 (0.22)	14 (0.55)	M10 screw, depth 18
30A2BTAR	230 (9.06)	200 ^{+0.122} _{+0.050} (7.87 ^{+0.0048} _{+0.0020})	260 (10.2)	4 (0.16)	15 (0.59)	76 (2.99)	6 (0.24)	11 (0.43)	70 (2.76)	56 (2.20)	φ50 ⁰ _{-0.016} (φ1.97 ⁰ _{-0.0006})	9 (0.35)	5.5 (0.22)	14 (0.55)	M10 screw, depth 18
30A2BTBR	230 (9.06)	200 ^{+0.122} _{+0.050} (7.87 ^{+0.0048} _{+0.0020})	260 (10.2)	4 (0.16)	15 (0.59)	76 (2.99)	6 (0.24)	11 (0.43)	70 (2.76)	56 (2.20)	φ50 ⁰ _{-0.016} (φ1.97 ⁰ _{-0.0006})	9 (0.35)	5.5 (0.22)	14 (0.55)	M10 screw, depth 18

5

Motor type SGMG-	Frange dimensions								Shaft end dimensions						
	LA	LB	LC	LE	LG	LR	N	LZ	Q	QK	S	T	U	W	V
44A2BTAR	230 (9.06)	200 ^{+0.122} _{+0.050} (7.87 ^{+0.0048} _{+0.0020})	260 (10.2)	4 (0.16)	15 (0.59)	76 (2.99)	6 (0.24)	11 (0.43)	70 (2.76)	56 (2.20)	φ50 ⁰ _{-0.016} (φ1.97 ⁰ _{-0.0006})	9 (0.35)	5.5 (0.22)	14 (0.55)	M10 screw, depth 18
44A2BTBR	230 (9.06)	200 ^{+0.122} _{+0.050} (7.87 ^{+0.0048} _{+0.0020})	260 (10.2)	4 (0.16)	15 (0.59)	96 (3.78)	6 (0.24)	11 (0.43)	90 (3.54)	80 (3.15)	φ50 ⁰ _{-0.016} (φ1.97 ⁰ _{-0.0006})	9 (0.35)	5.5 (0.22)	14 (0.55)	M10 screw, depth 18

Oil-lubrication type large size servomotors

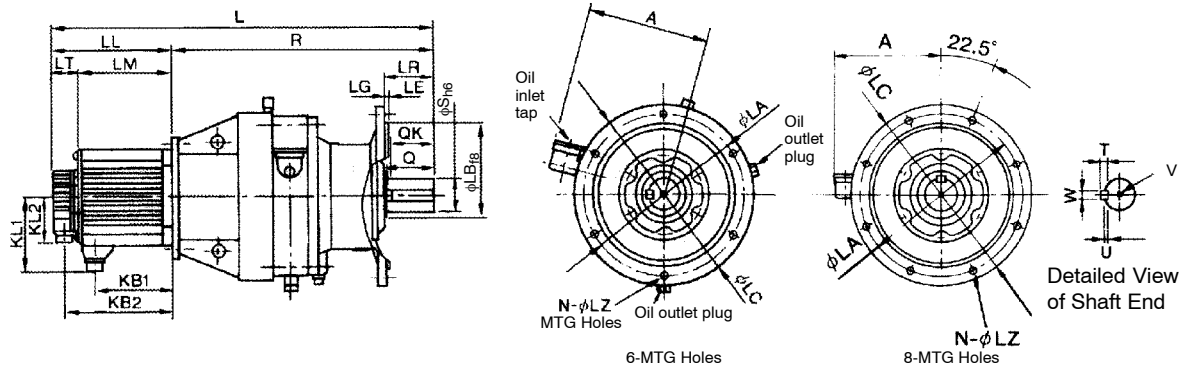

in mm (inches)

Motor type SGMG-	Gear type	Gear ratio	L	LL	LM	LT	KB1	KB2	KL1	KL2	R	A	Shaft center allowable radial load N	Approx. mass kg (lb)
20A2BT7R	CHVJ-4160	1/29	687 (27.1)	192 (7.56)	145 (5.71)	47 (1.85)	115 (4.53)	171 (6.73)	140 (5.51)	88 (3.46)	495 (19.5)	228 (8.98)	18520	121 (266.8)
30A2BTCR	CHVJ-4160	1/21	721 (28.4)	226 (8.90)	179 (7.05)	47 (1.85)	149 (5.87)	205 (8.07)	140 (5.51)	88 (3.46)	495 (19.5)	228 (8.98)	16740	126 (277.8)
30A2BT7R	CHVJ-4170	1/29	785 (30.9)	226 (8.90)	179 (7.05)	47 (1.85)	149 (5.87)	205 (8.07)	140 (5.51)	88 (3.46)	559 (22.0)	243 (9.57)	21770	176 (388.0)
44A2BTCR	CHVJ-4170	1/21	853 (33.6)	260 (10.2)	213 (8.39)	47 (1.85)	174 (6.85)	239 (9.41)	150 (5.91)	88 (3.46)	593 (23.4)	243 (9.57)	19560	191 (421.1)
44A2BT7R	CHVJ-4175	1/29	853 (33.6)	260 (10.2)	213 (8.39)	47 (1.85)	174 (6.85)	239 (9.41)	150 (5.91)	88 (3.46)	593 (23.4)	243 (9.57)	21790	191 (421.1)
60A2BTBR	CHVJ-4160	1/11	863 (34.0)	334 (13.2)	287 (11.3)	47 (1.85)	248 (9.76)	313 (12.3)	150 (5.91)	88 (3.46)	529 (20.8)	228 (8.98)	13470	150 (330.7)
60A2BTCR	CHVJ-4175	1/21	927 (36.5)	334 (13.2)	287 (11.3)	47 (1.85)	248 (9.76)	313 (12.3)	150 (5.91)	88 (3.46)	593 (23.4)	243 (9.57)	19560	201 (443.1)
60A2BT7R	CHVJ-4185	1/29	977 (38.5)	334 (13.2)	287 (11.3)	47 (1.85)	248 (9.76)	313 (12.3)	150 (5.91)	88 (3.46)	643 (25.3)	258 (10.2)	29200	232 (511.5)

USING THE DIGITAL OPERATOR

5.4.1 Servomotor Dimensional Drawings cont.

in mm (inches)

Motor type SGMG-	Flange dimensions								Shaft end dimensions						
	LA	LB	LC	LE	LG	LR	N	LZ	Q	QK	S	T	U	W	V
20A2BT7R	310 (12.2)	270 ^{+0.137} _{+0.056} (10.6 ^{+0.0054} _{+0.0022})	340 (13.4)	4 (0.16)	20 (0.79)	89 (3.50)	6 (0.24)	11 (0.43)	90 (3.54)	80 (3.15)	φ60 ⁰ _{-0.019} (φ2.36 ⁰ _{-0.0007})	11 (0.43)	7 (0.28)	18 (0.71)	M10 screw, depth 18
30A2BTCR	310 (12.2)	270 ^{+0.137} _{+0.056} (10.6 ^{+0.0054} _{+0.0024})	340 (13.4)	4 (0.16)	20 (0.79)	89 (3.50)	6 (0.24)	11 (0.43)	90 (3.54)	80 (3.15)	φ60 ⁰ _{-0.019} (φ2.36 ⁰ _{-0.0007})	11 (0.43)	7 (0.28)	18 (0.71)	M10 screw, depth 18
30A2BT7R	360 (14.2)	316 ^{+0.151} _{+0.062} (12.4 ^{+0.0059} _{+0.0024})	400 (15.7)	5 (0.20)	22 (0.87)	94 (3.70)	8 (0.31)	14 (0.55)	90 (3.54)	80 (3.15)	φ70 ⁰ _{-0.016} (φ2.76 ⁰ _{-0.0006})	12 (0.47)	7.5 (0.30)	20 (0.79)	M12 screw, depth 24
44A2BTCR	360 (14.2)	316 ^{+0.151} _{+0.062} (12.4 ^{+0.0059} _{+0.0024})	400 (15.7)	5 (0.20)	22 (0.87)	94 (3.70)	8 (0.31)	14 (0.55)	90 (3.54)	80 (3.15)	φ70 ⁰ _{-0.016} (φ2.76 ⁰ _{-0.0006})	12 (0.47)	7.5 (0.30)	20 (0.79)	M12 screw, depth 24
44A2BT7R	360 (14.2)	316 ^{+0.151} _{+0.062} (12.4 ^{+0.0059} _{+0.0024})	400 (15.7)	5 (0.20)	22 (0.87)	94 (3.70)	8 (0.31)	14 (0.55)	90 (3.54)	80 (3.15)	φ70 ⁰ _{-0.016} (φ2.76 ⁰ _{-0.0006})	12 (0.47)	7.5 (0.30)	20 (0.79)	M12 screw, depth 24
60A2BTBR	310 (12.2)	270 ^{+0.137} _{+0.056} (10.6 ^{+0.0054} _{+0.0022})	340 (13.4)	4 (0.16)	20 (0.79)	89 (3.50)	6 (0.24)	11 (0.43)	90 (3.54)	80 (3.15)	φ60 ⁰ _{-0.019} (φ2.36 ⁰ _{-0.0007})	11 (0.43)	5 (0.20)	18 (0.71)	M10 screw, depth 18
60A2BTCR	360 (14.2)	316 ^{+0.151} _{+0.062} (12.4 ^{+0.0059} _{+0.0024})	400 (15.7)	5 (0.20)	22 (0.87)	94 (3.70)	8 (0.31)	14 (0.55)	90 (3.54)	80 (3.15)	φ70 ⁰ _{-0.016} (φ2.76 ⁰ _{-0.0006})	12 (0.47)	7.5 (0.30)	20 (0.79)	M12 screw, depth 24
60A2BT7R	390 (15.4)	345 ^{+0.151} _{+0.062} (13.58 ^{+0.0059} _{+0.0024})	430 (16.9)	5 (0.20)	22 (0.87)	110 (4.33)	8 (0.31)	18 (0.71)	110 (4.33)	100 (3.94)	φ80 ⁰ _{-0.016} (φ3.15 ⁰ _{-0.0006})	14 (0.55)	9 (0.35)	22 (0.87)	M12 screw, depth 24

5

上正科技有限公司

購買、維修 此手冊零組件

電話： 037-466333

Email: service@repairtw.com

Line id: @zzzz

www.repairtw.com

Standard backlash gear (1000 min⁻¹), without brake

- Flange-mounted type

Grease-lubrication type small size servomotors

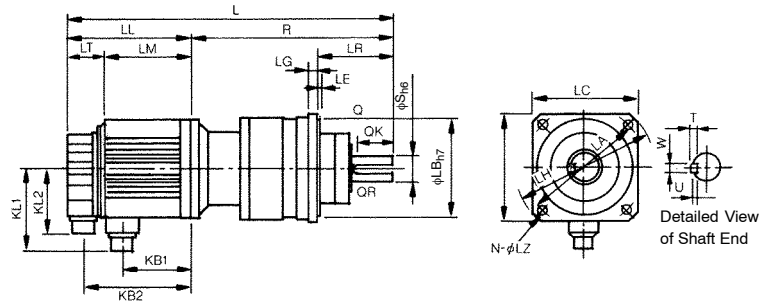

in mm (inches)

Motor type SGMG-	Gear type	Gear ratio	L	LL	LM	LR	LT	KB1	KB2	KL1	KL2	R	Shaft center allowable radial load N	Approx. mass kg (lb)
03A2BL1K	BL2	1/5	394 (15.5)	138 (5.43)	92 (3.62)	100 (3.94)	46 (1.81)	65 (2.56)	117 (4.61)	109 (4.29)	88 (3.46)	256 (10.1)	833	14 (30.9)
03A2BL2K		1/9	406 (16.0)	138 (5.43)	92 (3.62)	100 (3.94)	46 (1.81)	65 (2.56)	117 (4.61)	109 (4.29)	88 (3.46)	268 (10.6)	980	14 (30.9)
03A2BL5K		1/20	425 (16.7)	138 (5.43)	92 (3.62)	100 (3.94)	46 (1.81)	65 (2.56)	117 (4.61)	109 (4.29)	88 (3.46)	287 (11.3)	1270	16 (35.3)
06A2BL1K	BL2	1/5	417 (16.4)	161 (6.34)	115 (4.53)	100 (3.94)	46 (1.81)	88 (3.46)	140 (5.51)	109 (4.29)	88 (3.46)	256 (10.1)	833	16 (35.3)
06A2BL2K		1/9	429 (16.9)	161 (6.34)	115 (4.53)	100 (3.94)	46 (1.81)	88 (3.46)	140 (5.51)	109 (4.29)	88 (3.46)	268 (10.6)	980	16 (35.3)
09A2BL1K	BL2	1/5	441 (17.4)	185 (7.28)	139 (5.47)	100 (3.94)	46 (1.81)	112 (4.41)	164 (6.46)	109 (4.29)	88 (3.46)	256 (10.1)	833	18 (39.7)

5

Email: service@repairtw.com

in mm (inches)

Motor type SGMG-	Flange dimensions								Shaft end dimensions						
	LA	LB	LC	LE	LG	LH	N	LZ	S	Q	QK	QR	T	U	W
03A2BL1K	160 (6.30)	130 ⁰ _{-0.040} (5.12 ⁰ _{-0.0016})	140 (5.51)	3 (0.12)	12 (0.47)	185 (7.28)	4 (0.16)	12 (0.47)	35 ⁰ _{-0.016} (1.38 ⁰ _{-0.0006})	55 (2.17)	47 (1.85)	1 (0.039)	8 (0.31)	5 (0.20)	10 (0.39)
03A2BL2K	160 (6.30)	130 ⁰ _{-0.040} (5.12 ⁰ _{-0.0016})	140 (5.51)	3 (0.12)	12 (0.47)	185 (7.28)	4 (0.16)	12 (0.47)	35 ⁰ _{-0.016} (1.38 ⁰ _{-0.0006})	55 (2.17)	47 (1.85)	1 (0.039)	8 (0.31)	5 (0.20)	10 (0.39)
03A2BL5K	160 (6.30)	130 ⁰ _{-0.040} (5.12 ⁰ _{-0.0016})	140 (5.51)	3 (0.12)	12 (0.47)	185 (7.28)	4 (0.16)	12 (0.47)	35 ⁰ _{-0.016} (1.38 ⁰ _{-0.0006})	55 (2.17)	47 (1.85)	1 (0.039)	8 (0.31)	5 (0.20)	10 (0.39)
06A2BL1K	160 (6.30)	130 ⁰ _{-0.040} (5.12 ⁰ _{-0.0016})	140 (5.51)	3 (0.12)	12 (0.47)	185 (7.28)	4 (0.16)	12 (0.47)	35 ⁰ _{-0.016} (1.38 ⁰ _{-0.0006})	55 (2.17)	47 (1.85)	1 (0.039)	8 (0.31)	5 (0.20)	10 (0.39)
06A2BL2K	160 (6.30)	130 ⁰ _{-0.040} (5.12 ⁰ _{-0.0016})	140 (5.51)	3 (0.12)	12 (0.47)	185 (7.28)	4 (0.16)	12 (0.47)	35 ⁰ _{-0.016} (1.38 ⁰ _{-0.0006})	55 (2.17)	47 (1.85)	1 (0.039)	8 (0.31)	5 (0.20)	10 (0.39)
09A2BL1K	160 (6.30)	130 ⁰ _{-0.040} (5.12 ⁰ _{-0.0016})	140 (5.51)	3 (0.12)	12 (0.47)	185 (7.28)	4 (0.16)	12 (0.47)	35 ⁰ _{-0.016} (1.38 ⁰ _{-0.0006})	55 (2.17)	47 (1.85)	1 (0.039)	8 (0.31)	5 (0.20)	10 (0.39)

Grease-lubrication type large size servomotors

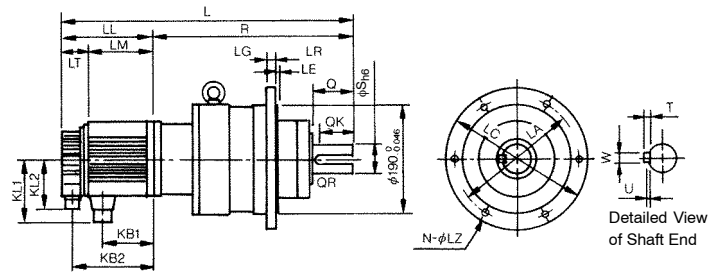

in mm (inches)

Motor type SGMG-	Gear type	Gear ratio	L	LL	LM	LR	LT	KB1	KB2	KL1	KL2	R	Shaft center allowable radial load N	Approx. mass kg (lb)
03A2BL7K	BL3	1/29	491 (19.3)	138 (5.43)	92 (3.62)	140 (5.51)	46 (1.81)	65 (2.56)	117 (4.61)	109 (4.29)	88 (3.46)	353 (13.9)	2940	31 (68.3)
03A2BL8K		1/45	501 (19.7)	138 (5.43)	92 (3.62)	140 (5.51)	46 (1.81)	65 (2.56)	117 (4.61)	109 (4.29)	88 (3.46)	363 (14.3)	3430	31 (68.3)
06A2BL5K	BL3	1/20	514 (20.2)	161 (6.34)	115 (4.53)	140 (5.51)	46 (1.81)	88 (3.46)	140 (5.51)	109 (4.29)	88 (3.46)	353 (13.9)	2650	33 (72.8)
06A2BL7K		1/29	514 (20.2)	161 (6.34)	115 (4.53)	140 (5.51)	46 (1.81)	88 (3.46)	140 (5.51)	109 (4.29)	88 (3.46)	353 (13.9)	2940	33 (72.8)
06A2BL8K	BL4	1/45	565 (22.2)	161 (6.34)	115 (4.53)	160 (6.30)	46 (1.81)	88 (3.46)	140 (5.51)	109 (4.29)	88 (3.46)	404 (15.9)	8040	53 (116.8)
09A2BL2K	BL3	1/9	534 (21.0)	185 (7.28)	139 (5.47)	140 (5.51)	46 (1.81)	112 (4.41)	164 (6.46)	109 (4.29)	88 (3.46)	349 (13.7)	1960	35 (77.2)
09A2BL5K		1/20	538 (21.2)	185 (7.28)	139 (5.47)	140 (5.51)	46 (1.81)	112 (4.41)	164 (6.46)	109 (4.29)	88 (3.46)	353 (13.9)	2650	35 (77.2)
09A2BL7K	BL4	1/29	579 (22.8)	185 (7.28)	139 (5.47)	160 (6.30)	46 (1.81)	112 (4.41)	164 (6.46)	109 (4.29)	88 (3.46)	394 (15.5)	6860	55 (121.2)
09A2BL8K		1/45	589 (23.2)	185 (7.28)	139 (5.47)	160 (6.30)	46 (1.81)	112 (4.41)	164 (6.46)	109 (4.29)	88 (3.46)	404 (15.9)	8040	55 (121.2)
12A2BL1K	BL3	1/5	509 (20.0)	166 (6.54)	119 (4.69)	140 (5.51)	47 (1.85)	89 (3.50)	145 (5.71)	140 (5.51)	88 (3.46)	343 (13.5)	1670	32 (70.5)
12A2BL2K		1/9	536 (21.1)	166 (6.54)	119 (4.69)	140 (5.51)	47 (1.85)	89 (3.50)	145 (5.71)	140 (5.51)	88 (3.46)	370 (14.6)	1960	39 (86.0)
12A2BL5K	BL4	1/20	581 (22.9)	166 (6.54)	119 (4.69)	160 (6.30)	47 (1.85)	89 (3.50)	145 (5.71)	140 (5.51)	88 (3.46)	415 (16.3)	6080	59 (130.1)
12A2BL7K		1/29	581 (22.9)	166 (6.54)	119 (4.69)	160 (6.30)	47 (1.85)	89 (3.50)	145 (5.71)	140 (5.51)	88 (3.46)	415 (16.3)	6860	59 (130.1)
12A2BL8K		1/45	591 (23.3)	166 (6.54)	119 (4.69)	160 (6.30)	47 (1.85)	89 (3.50)	145 (5.71)	140 (5.51)	88 (3.46)	425 (16.7)	8040	59 (130.1)
20A2BL1K	BL3	1/5	535 (21.1)	192 (7.56)	145 (5.71)	140 (5.51)	47 (1.85)	115 (4.53)	171 (6.73)	140 (5.51)	88 (3.46)	343 (13.5)	1670	36 (79.4)
20A2BL2K		1/9	562 (22.1)	192 (7.56)	145 (5.71)	140 (5.51)	47 (1.85)	115 (4.53)	171 (6.73)	140 (5.51)	88 (3.46)	370 (14.6)	1960	43 (94.8)
20A2BL5K	BL4	1/20	607 (23.9)	192 (7.56)	145 (5.71)	160 (6.30)	47 (1.85)	115 (4.53)	171 (6.73)	140 (5.51)	88 (3.46)	415 (16.3)	6080	63 (138.9)
30A2BL1K	BL4	1/5	609 (24.0)	226 (8.90)	179 (7.05)	160 (6.30)	47 (1.85)	149 (5.87)	205 (8.07)	140 (5.51)	88 (3.46)	383 (15.1)	3820	58 (127.9)
30A2BL2K		1/9	641 (25.2)	226 (8.90)	179 (7.05)	160 (6.30)	47 (1.85)	149 (5.87)	205 (8.07)	140 (5.51)	88 (3.46)	415 (16.3)	4700	68 (149.9)

in mm (inches)

Motor type SGMG-	Flange dimensions							Shaft end dimensions						
	LA	LB	LC	LE	LG	N	LZ	S	Q	QK	QR	T	U	W
03A2BL7K	220 (8.66)	$190^{0}_{-0.046}$ (7.48 ⁰ _{-0.0018})	245 (9.65)	5 (0.20)	15 (0.59)	6	12 (0.47)	$50^{0}_{-0.016}$ (1.97 ⁰ _{-0.0006})	75 (2.95)	65 (2.56)	1 (0.039)	9 (0.35)	5.5 (0.22)	14 (0.55)
03A2BL8K	220 (8.66)	$190^{0}_{-0.046}$ (7.48 ⁰ _{-0.0018})	245 (9.65)	5 (0.20)	15 (0.59)	6	12 (0.47)	$50^{0}_{-0.016}$ (1.97 ⁰ _{-0.0006})	75 (2.95)	65 (2.56)	1 (0.039)	9 (0.35)	5.5 (0.22)	14 (0.55)
06A2BL5K	220 (8.66)	$190^{0}_{-0.046}$ (7.48 ⁰ _{-0.0018})	245 (9.65)	5 (0.20)	15 (0.59)	6	12 (0.47)	$50^{0}_{-0.016}$ (1.97 ⁰ _{-0.0006})	75 (2.95)	65 (2.56)	1 (0.039)	9 (0.35)	5.5 (0.22)	14 (0.55)
06A2BL7K	220 (8.66)	$190^{0}_{-0.046}$ (7.48 ⁰ _{-0.0018})	245 (9.65)	5 (0.20)	15 (0.59)	6	12 (0.47)	$50^{0}_{-0.016}$ (1.97 ⁰ _{-0.0006})	75 (2.95)	65 (2.56)	1 (0.039)	9 (0.35)	5.5 (0.22)	14 (0.55)
06A2BL8K	280 (11.0)	$240^{0}_{-0.046}$ (9.45 ⁰ _{-0.0018})	310 (12.2)	5 (0.20)	18 (0.71)	6	14 (0.55)	$60^{0}_{-0.019}$ (2.36 ⁰ _{-0.0007})	90 (3.54)	78 (3.07)	1 (0.039)	11 (0.43)	7 (0.28)	18 (0.71)
09A2BL2K	220 (8.66)	$190^{0}_{-0.046}$ (7.48 ⁰ _{-0.0018})	245 (9.65)	5 (0.20)	15 (0.59)	6	12 (0.47)	$50^{0}_{-0.016}$ (1.97 ⁰ _{-0.0006})	75 (2.95)	65 (2.56)	1 (0.039)	9 (0.35)	5.5 (0.22)	14 (0.55)
09A2BL5K	220 (8.66)	$190^{0}_{-0.046}$ (7.48 ⁰ _{-0.0018})	245 (9.65)	5 (0.20)	15 (0.59)	6	12 (0.47)	$50^{0}_{-0.016}$ (1.97 ⁰ _{-0.0006})	75 (2.95)	65 (2.56)	1 (0.039)	9 (0.35)	5.5 (0.22)	14 (0.55)
09A2BL7K	280 (11.0)	$240^{0}_{-0.046}$ (9.45 ⁰ _{-0.0018})	310 (12.2)	5 (0.20)	18 (0.71)	6	14 (0.55)	$60^{0}_{-0.019}$ (2.36 ⁰ _{-0.0007})	90 (3.54)	78 (3.07)	1 (0.039)	11 (0.43)	7 (0.28)	18 (0.71)
09A2BL8K	280 (11.0)	$240^{0}_{-0.046}$ (9.45 ⁰ _{-0.0018})	310 (12.2)	5 (0.20)	18 (0.71)	6	14 (0.55)	$60^{0}_{-0.019}$ (2.36 ⁰ _{-0.0007})	90 (3.54)	78 (3.07)	1 (0.039)	11 (0.43)	7 (0.28)	18 (0.71)
12A2BL1K	220 (8.66)	$190^{0}_{-0.046}$ (7.48 ⁰ _{-0.0018})	245 (9.65)	5 (0.20)	15 (0.59)	6	12 (0.47)	$50^{0}_{-0.016}$ (1.97 ⁰ _{-0.0006})	75 (2.95)	65 (2.56)	1 (0.039)	9 (0.35)	5.5 (0.22)	14 (0.55)
12A2BL2K	220 (8.66)	$190^{0}_{-0.046}$ (7.48 ⁰ _{-0.0018})	245 (9.65)	5 (0.20)	15 (0.59)	6	12 (0.47)	$50^{0}_{-0.016}$ (1.97 ⁰ _{-0.0006})	75 (2.95)	65 (2.56)	1 (0.039)	9 (0.35)	5.5 (0.22)	14 (0.55)
12A2BL5K	280 (11.0)	$240^{0}_{-0.046}$ (9.45 ⁰ _{-0.0018})	310 (12.2)	5 (0.20)	18 (0.71)	6	14 (0.55)	$60^{0}_{-0.019}$ (2.36 ⁰ _{-0.0007})	90 (3.54)	78 (3.07)	1 (0.039)	11 (0.43)	7 (0.28)	18 (0.71)
12A2BL7K	280 (11.0)	$240^{0}_{-0.046}$ (9.45 ⁰ _{-0.0018})	310 (12.2)	5 (0.20)	18 (0.71)	6	14 (0.55)	$60^{0}_{-0.019}$ (2.36 ⁰ _{-0.0007})	90 (3.54)	78 (3.07)	1 (0.039)	11 (0.43)	7 (0.28)	18 (0.71)
12A2BL8K	280 (11.0)	$240^{0}_{-0.046}$ (9.45 ⁰ _{-0.0018})	310 (12.2)	5 (0.20)	18 (0.71)	6	14 (0.55)	$60^{0}_{-0.019}$ (2.36 ⁰ _{-0.0007})	90 (3.54)	78 (3.07)	1 (0.039)	11 (0.43)	7 (0.28)	18 (0.71)
20A2BL1K	220 (8.66)	$190^{0}_{-0.046}$ (7.48 ⁰ _{-0.0018})	245 (9.65)	5 (0.20)	15 (0.59)	6	12 (0.47)	$50^{0}_{-0.016}$ (1.97 ⁰ _{-0.0006})	75 (2.95)	65 (2.56)	1 (0.039)	9 (0.35)	5.5 (0.22)	14 (0.55)
20A2BL2K	220 (8.66)	$190^{0}_{-0.046}$ (7.48 ⁰ _{-0.0018})	245 (9.65)	5 (0.20)	15 (0.59)	6	12 (0.47)	$50^{0}_{-0.016}$ (1.97 ⁰ _{-0.0006})	75 (2.95)	65 (2.56)	1 (0.039)	9 (0.35)	5.5 (0.22)	14 (0.55)
20A2BL5K	280 (11.0)	$240^{0}_{-0.046}$ (9.45 ⁰ _{-0.0018})	310 (12.2)	5 (0.20)	18 (0.71)	6	14 (0.55)	$60^{0}_{-0.019}$ (2.36 ⁰ _{-0.0007})	90 (3.54)	78 (3.07)	1 (0.039)	11 (0.43)	7 (0.28)	18 (0.71)
30A2BL1K	280 (11.0)	$240^{0}_{-0.046}$ (9.45 ⁰ _{-0.0018})	310 (12.2)	5 (0.20)	18 (0.71)	6	14 (0.55)	$60^{0}_{-0.019}$ (2.36 ⁰ _{-0.0007})	90 (3.54)	78 (3.07)	1 (0.039)	11 (0.43)	7 (0.28)	18 (0.71)
30A2BL2K	280 (11.0)	$240^{0}_{-0.046}$ (9.45 ⁰ _{-0.0018})	310 (12.2)	5 (0.20)	18 (0.71)	6	14 (0.55)	$60^{0}_{-0.019}$ (2.36 ⁰ _{-0.0007})	90 (3.54)	78 (3.07)	1 (0.039)	11 (0.43)	7 (0.28)	18 (0.71)

Shaft end tap specifications

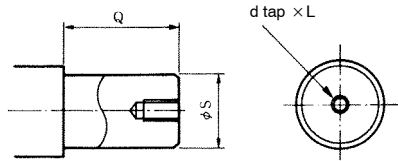

in mm (inches)

Gear type	Shaft diameter S	Shaft length Q	d × L
BL2	35 (1.38)	55 (2.17)	M8 × 16
BL3	50 (1.97)	75 (2.95)	M10 × 20
BL4	60 (2.36)	90 (3.54)	M12 × 24

Detailed dimensions of IMT gear

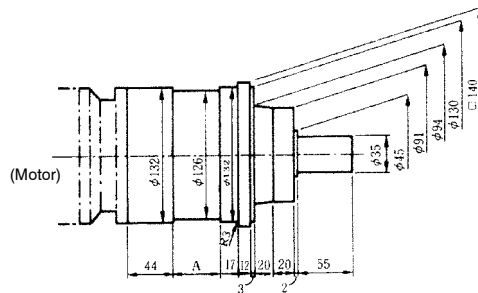

(BL 2)

in mm (inches)

Gear ratio	A
1/5	6 (0.24)
1/9	18 (0.71)
1/20, 1/29	39 (1.54)
1/45	47 (1.85)

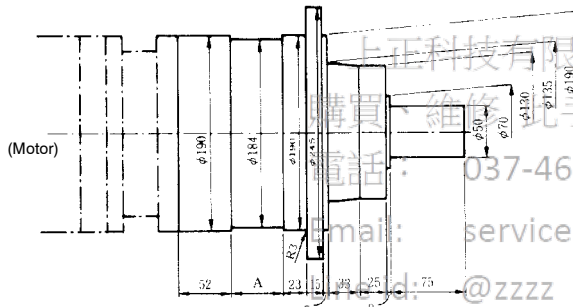

(BL 3)

in mm (inches)

Gear ratio	A
1/5	11 (0.43)
1/9	38 (1.50)
1/20, 1/29	46 (1.81)
1/45	52 (2.05)

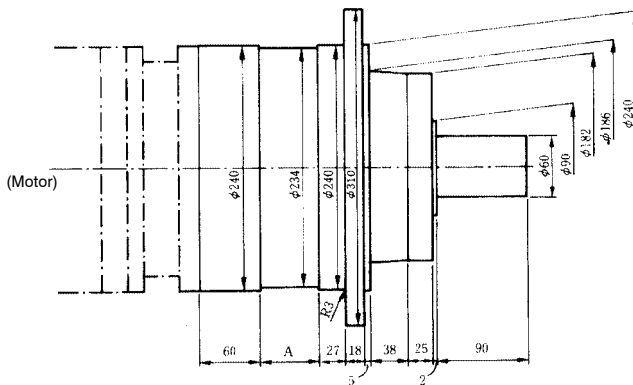

(BL 4)

in mm (inches)

Gear ratio	A
1/5	16 (0.63)
1/9	48 (1.89)
1/20, 1/29	55 (2.17)
1/45	58 (2.28)

■ SGMS-□□A Servomotor

Incremental encoder (4096 P/R)

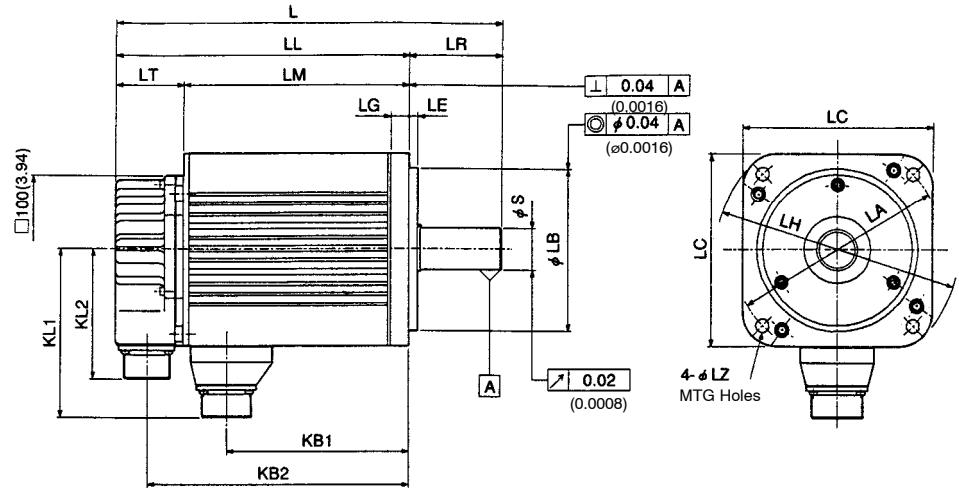

Detailed View of Shaft End

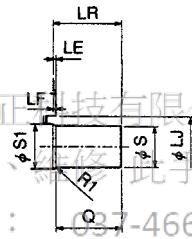

上正科技有限公司
 購買、維修此手冊零組件
 電話：037-466333

Email: service@repairtw.com

Line id: @7777

in mm (inches)

Type SGMS-	L	LL	LM	LR	LT	KB1	KB2	KL1	KL2
10A6A	194 (7.64)	149 (5.87)	103 (4.06)	45 (1.77)	46 (1.81)	76 (2.99)	128 (5.04)	96 (3.78)	87 (3.43)
15A6A	220 (8.66)	175 (6.89)	129 (5.08)	45 (1.77)	46 (1.81)	102 (4.02)	154 (6.06)	96 (3.78)	87 (3.43)
20A6A	243 (9.57)	198 (7.80)	152 (5.98)	45 (1.77)	46 (1.81)	125 (4.92)	177 (6.97)	96 (3.78)	87 (3.43)
30A6A	262 (10.31)	199 (7.83)	153 (6.02)	63 (2.48)	46 (1.81)	122 (4.80)	178 (7.01)	114 (4.49)	87 (3.43)
40A6A	299 (11.77)	236 (9.29)	190 (7.48)	63 (2.48)	46 (1.81)	159 (6.26)	215 (8.46)	114 (4.49)	87 (3.43)
50A6A	339 (13.35)	276 (10.87)	230 (9.06)	63 (2.48)	46 (1.81)	199 (7.83)	255 (10.04)	114 (4.49)	87 (3.43)

in mm (inches)

Type SGMS-	Flange dimensions								
	LA	LB	LC	LE	LF	LG	LH	LJ	LZ
10A6A	115 (4.53)	95 ⁰ _{-0.035} (3.74 ⁰ _{-0.0014})	100 (3.94)	3 (0.12)	3 (0.12)	10 (0.39)	130 (5.12)	45 (1.77)	7 (0.28)
15A6A	115 (4.53)	95 ⁰ _{-0.035} (3.74 ⁰ _{-0.0014})	100 (3.94)	3 (0.12)	3 (0.12)	10 (0.39)	130 (5.12)	45 (1.77)	7 (0.28)
20A6A	115 (4.53)	95 ⁰ _{-0.035} (3.74 ⁰ _{-0.0014})	100 (3.94)	3 (0.12)	3 (0.12)	10 (0.39)	130 (5.12)	45 (1.77)	7 (0.28)
30A6A	145 (5.71)	110 ⁰ _{-0.035} (4.33 ⁰ _{-0.0014})	130 (5.12)	6 (0.24)	6 (0.24)	12 (0.47)	165 (6.50)	45 (1.77)	9 (0.35)
40A6A	145 (5.71)	110 ⁰ _{-0.035} (4.33 ⁰ _{-0.0014})	130 (5.12)	6 (0.24)	6 (0.24)	12 (0.47)	165 (6.50)	45 (1.77)	9 (0.35)
50A6A	145 (5.71)	110 ⁰ _{-0.035} (4.33 ⁰ _{-0.0014})	130 (5.12)	6 (0.24)	6 (0.24)	12 (0.47)	165 (6.50)	45 (1.77)	9 (0.35)

上正科技有限公司

購買、維修 此手冊零組件

電話： 037-466333

Email: service@repairtw.com

Line id: @zzzz

www.repairtw.com

in mm (inches)

Type SGMS-	Shaft end dimensions			Approx. mass kg (lb)
	S	S1	Q	
10A6A	$24 \begin{smallmatrix} 0 \\ - 0.013 \\ 0 \\ (0.94 - 0.0005) \end{smallmatrix}$	30 (1.18)	40 (1.57)	4.6 (10.14)
15A6A	$24 \begin{smallmatrix} 0 \\ - 0.013 \\ 0 \\ (0.94 - 0.0005) \end{smallmatrix}$	30 (1.18)	40 (1.57)	5.8 (12.78)
20A6A	$24 \begin{smallmatrix} 0 \\ - 0.013 \\ 0 \\ (0.94 - 0.0005) \end{smallmatrix}$	30 (1.18)	40 (1.57)	7.0 (15.43)
30A6A	$28 \begin{smallmatrix} 0 \\ - 0.013 \\ 0 \\ (1.10 - 0.0005) \end{smallmatrix}$	30 (1.18)	55 (2.17)	11 (24.24)
40A6A	$28 \begin{smallmatrix} 0 \\ - 0.013 \\ 0 \\ (1.10 - 0.0005) \end{smallmatrix}$	30 (1.18)	55 (2.17)	14 (30.86)
50A6A	$28 \begin{smallmatrix} 0 \\ - 0.013 \\ 0 \\ (1.10 - 0.0005) \end{smallmatrix}$	30 (1.18)	55 (2.17)	17 (37.47)

上正科技有限公司
Note Incremental encoder (4096 P/R) is used as a detector.

購買、維修 此手冊零組件

電話： 037-466333

Email: service@repairtw.com

Line id: @zzzz

www.repairtw.com

• Connector Wiring on Detector Side

Receptacle: MS3102A20-29P

Plug (To be prepared by customer) (L type): MS3108B20-29S or
(Straight type) MS3106B20-29S

Cable Clamp: (To be prepared by customer) MS3057-12A

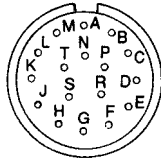

Encoder Wiring Specifications

A	A channel output	K	
B	/A channel output	L	
C	B channel output	M	
D	/B channel output	N	
E	C channel output	P	
F	/C channel output	R	
G	0V	S	
H	+5V DC	T	
J	FG (Frame Ground)		

- Note**
- 1) Terminals K to T are not used. Do not connect anything.
 - 2) Receptacle, plug and cable clamp are common regardless of motor capacity.

• Connector Wiring on Motor Side



Motor Wiring Specifications

A	Phase U
B	Phase V
C	Phase W
D	Ground terminal

- Note** Receptacle, plug and cable clamp differ depending on the capacity. Refer to 6) Connectors on Detector and Motor Sides (page 392).

Incremental encoder (4096 P/R), with brake

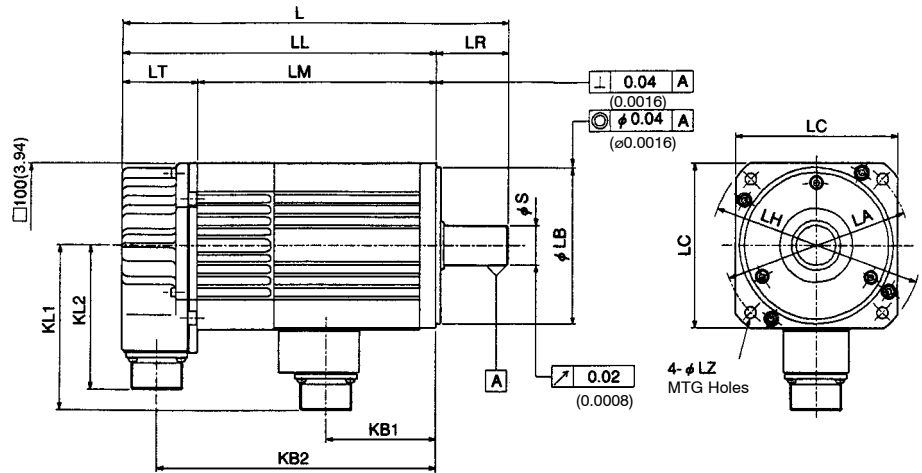

Detailed View of Shaft End

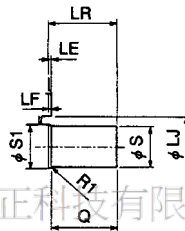

上正科技有限公司
 購買、維修 此手冊零組件
 電話： 037-466333

in mm (inches)

Type SGMS-	L	LL	LM	LR	LT	KB1	KB2	KL1	KL2
10A6AAB	238 (9.37)	193 (7.60)	147 (5.79)	45 (1.77)	46 (1.81)	67 (2.64)	172 (6.77)	100 (3.94)	87 (3.43)
15A6AAB	264 (10.39)	219 (8.62)	173 (6.81)	45 (1.77)	46 (1.81)	93 (3.66)	198 (7.80)	100 (3.94)	87 (3.43)
20A6AAB	287 (11.30)	242 (9.53)	196 (7.72)	45 (1.77)	46 (1.81)	116 (4.57)	221 (8.70)	100 (3.94)	87 (3.43)
30A6AAB	300 (11.81)	237 (9.33)	191 (7.52)	63 (2.48)	46 (1.81)	113 (4.45)	216 (8.50)	119 (4.69)	87 (3.43)
40A6AAB	336 (13.23)	274 (10.79)	228 (8.98)	63 (2.48)	46 (1.81)	150 (5.91)	253 (9.96)	119 (4.69)	87 (3.43)
50A6AAB	337 (13.27)	314 (12.36)	268 (10.55)	63 (2.48)	46 (1.81)	190 (7.48)	293 (11.54)	119 (4.69)	87 (3.43)

in mm (inches)

Type SGMS-	Flange dimensions								
	LA	LB	LC	LE	LF	LG	LH	LJ	LZ
10A6AAB	115 (4.53)	$95 \begin{smallmatrix} 0 \\ - 0.035 \\ 0 \\ (3.74 - 0.0014) \end{smallmatrix}$	100 (3.94)	3 (0.12)	3 (0.12)	10 (0.39)	130 (5.12)	45 (1.77)	7 (0.28)
15A6AAB	115 (4.53)	$95 \begin{smallmatrix} 0 \\ - 0.035 \\ 0 \\ (3.74 - 0.0014) \end{smallmatrix}$	100 (3.94)	3 (0.12)	3 (0.12)	10 (0.39)	130 (5.12)	45 (1.77)	7 (0.28)
20A6AAB	115 (4.53)	$95 \begin{smallmatrix} 0 \\ - 0.035 \\ 0 \\ (3.74 - 0.0014) \end{smallmatrix}$	100 (3.94)	3 (0.12)	3 (0.12)	10 (0.39)	130 (5.12)	45 (1.77)	7 (0.28)
30A6AAB	145 (5.71)	$110 \begin{smallmatrix} 0 \\ - 0.035 \\ 0 \\ (4.33 - 0.0014) \end{smallmatrix}$	130 (5.12)	6 (0.24)	6 (0.24)	12 (0.47)	165 (6.50)	45 (1.77)	9 (0.35)
40A6AAB	145 (5.71)	$110 \begin{smallmatrix} 0 \\ - 0.035 \\ 0 \\ (4.33 - 0.0014) \end{smallmatrix}$	130 (5.12)	6 (0.24)	6 (0.24)	12 (0.47)	165 (6.50)	45 (1.77)	9 (0.35)
50A6AAB	145 (5.71)	$110 \begin{smallmatrix} 0 \\ - 0.035 \\ 0 \\ (4.33 - 0.0014) \end{smallmatrix}$	130 (5.12)	6 (0.24)	6 (0.24)	12 (0.47)	165 (6.50)	45 (1.77)	9 (0.35)

上正科技有限公司

購買、維修 此手冊零組件

電話： 037-466333

Email: service@repairtw.com

Line id: @zzzz

www.repairtw.com

in mm (inches)

Type SGMS-	Shaft end dimensions			Approx. mass kg (lb)
	S	S1	Q	
10A6AAB	$24 \begin{smallmatrix} 0 \\ - 0.013 \\ 0 \\ (0.94 - 0.0005) \end{smallmatrix}$	30 (1.18)	40 (1.57)	6.0 (13.22)
15A6AAB	$24 \begin{smallmatrix} 0 \\ - 0.013 \\ 0 \\ (0.94 - 0.0005) \end{smallmatrix}$	30 (1.18)	40 (1.57)	7.5 (16.53)
20A6AAB	$24 \begin{smallmatrix} 0 \\ - 0.013 \\ 0 \\ (0.94 - 0.0005) \end{smallmatrix}$	30 (1.18)	40 (1.57)	8.5 (18.73)
30A6AAB	$28 \begin{smallmatrix} 0 \\ - 0.013 \\ 0 \\ (1.10 - 0.0005) \end{smallmatrix}$	30 (1.18)	55 (2.17)	14 (30.86)
40A6AAB	$28 \begin{smallmatrix} 0 \\ - 0.013 \\ 0 \\ (1.10 - 0.0005) \end{smallmatrix}$	30 (1.18)	55 (2.17)	17 (37.47)
50A6AAB	$28 \begin{smallmatrix} 0 \\ - 0.013 \\ 0 \\ (1.10 - 0.0005) \end{smallmatrix}$	30 (1.18)	55 (2.17)	20 (44.08)

上正科技有限公司

Note Incremental encoder (4096 P/R) is used as a detector.

購買、維修 此手冊零件

電話: 037-466333

- Connector Wiring on Motor Side

Email: service@repairtw.com

Life: @zzzz

www.repairtw.com



A	Phase U	E	Brake terminal
B	Phase V	F	Brake terminal
C	Phase W	G	-
D	Frame ground (FG)		

Absolute encoder (15bit : 8192 P/R)

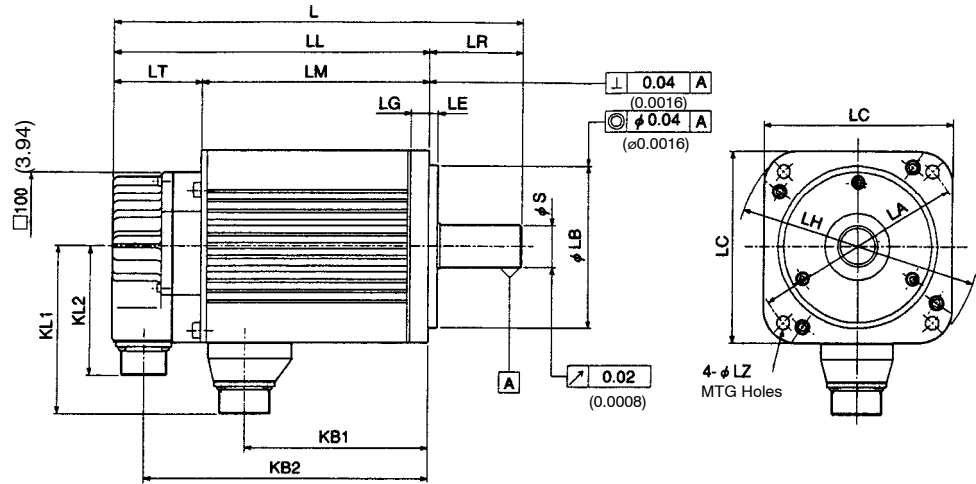

Detailed View of Shaft End

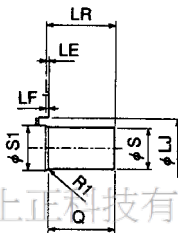

5

上正科技有限公司

購買、維修 此手冊零組件

電話： 037-466333

in mm (inches)

Type SGMS-	L	LL	LM	LR	LT	KB1	KB2	KL1	KL2
10ASA	208 (8.19)	163 (6.42)	103 (4.06)	45 (1.77)	60 (2.36)	76 (2.99)	142 (5.59)	96 (3.78)	87 (3.43)
15ASA	234 (9.21)	189 (7.44)	129 (5.08)	45 (1.77)	60 (2.36)	102 (4.02)	168 (6.61)	96 (3.78)	87 (3.43)
20ASA	257 (10.12)	212 (8.35)	152 (5.98)	45 (1.77)	60 (2.36)	125 (4.92)	191 (7.52)	96 (3.78)	87 (3.43)
30ASA	276 (10.87)	213 (8.39)	153 (6.02)	63 (2.48)	60 (2.36)	122 (4.80)	192 (7.56)	114 (4.49)	87 (3.43)
40ASA	313 (12.32)	250 (9.84)	190 (7.48)	63 (2.48)	60 (2.36)	159 (6.26)	229 (9.02)	114 (4.49)	87 (3.43)
50ASA	353 (13.90)	290 (11.42)	230 (9.06)	63 (2.48)	60 (2.36)	199 (7.83)	269 (10.59)	114 (4.49)	87 (3.43)

in mm (inches)

Type SGMS-	Flange dimensions								
	LA	LB	LC	LE	LF	LG	LH	LJ	LZ
10ASA	115 (4.53)	95 ⁰ _{-0.035} (3.74 ⁰ _{-0.0014})	100 (3.94)	3 (0.12)	3 (0.12)	10 (0.39)	130 (5.12)	45 (1.77)	7 (0.28)
15ASA	115 (4.53)	95 ⁰ _{-0.035} (3.74 ⁰ _{-0.0014})	100 (3.94)	3 (0.12)	3 (0.12)	10 (0.39)	130 (5.12)	45 (1.77)	7 (0.28)
20ASA	115 (4.53)	95 ⁰ _{-0.035} (3.74 ⁰ _{-0.0014})	100 (3.94)	3 (0.12)	3 (0.12)	10 (0.39)	130 (5.12)	45 (1.77)	7 (0.28)
30ASA	145 (5.71)	110 ⁰ _{-0.035} (4.33 ⁰ _{-0.0014})	130 (5.12)	6 (0.24)	6 (0.24)	12 (0.47)	165 (6.50)	45 (1.77)	9 (0.35)
40ASA	145 (5.71)	110 ⁰ _{-0.035} (4.33 ⁰ _{-0.0014})	130 (5.12)	6 (0.24)	6 (0.24)	12 (0.47)	165 (6.50)	45 (1.77)	9 (0.35)
50ASA	145 (5.71)	110 ⁰ _{-0.035} (4.33 ⁰ _{-0.0014})	130 (5.12)	6 (0.24)	6 (0.24)	12 (0.47)	165 (6.50)	45 (1.77)	9 (0.35)

上正科技有限公司

購買、維修 此手冊零組件

電話： 037-466333

Email: service@repairtw.com

Line id: @zzzz

www.repairtw.com

in mm (inches)

Type SGMS-	Shaft end dimensions			Approx. mass kg (lb)
	S	S1	Q	
10ASA	$24 \begin{smallmatrix} 0 \\ - 0.013 \\ 0 \end{smallmatrix}$ (0.94 - 0.0005)	30 (1.18)	40 (1.57)	5.0 (11.02)
15ASA	$24 \begin{smallmatrix} 0 \\ - 0.013 \\ 0 \end{smallmatrix}$ (0.94 - 0.0005)	30 (1.18)	40 (1.57)	6.2 (13.66)
20ASA	$24 \begin{smallmatrix} 0 \\ - 0.013 \\ 0 \end{smallmatrix}$ (0.94 - 0.0005)	30 (1.18)	40 (1.57)	7.4 (16.31)
30ASA	$28 \begin{smallmatrix} 0 \\ - 0.013 \\ 0 \end{smallmatrix}$ (1.10 - 0.0005)	30 (1.18)	55 (2.17)	11.5 (25.35)
40ASA	$28 \begin{smallmatrix} 0 \\ - 0.013 \\ 0 \end{smallmatrix}$ (1.10 - 0.0005)	30 (1.18)	55 (2.17)	14.5 (31.96)
50ASA	$28 \begin{smallmatrix} 0 \\ - 0.013 \\ 0 \end{smallmatrix}$ (1.10 - 0.0005)	30 (1.18)	55 (2.17)	17.5 (38.57)

Note Absolute encoder (15bit : 8192 P/R) is used as a detector.

上正科技有限公司

購買、維修 此手冊零組件

電話： 037-466333

Email: service@repairtw.com

Line id: @zzzz

www.repairtw.com

• Connector Wiring on Detector Side

Receptacle: MS3102A20-29P

Plug (To be prepared by customer) (L type): MS3108B20-29S or
(Straight type) MS3106B20-29S

Cable Clamp: (To be prepared by customer) MS3057-12A

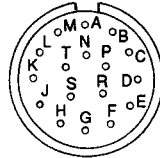

Encoder Wiring Specifications

A	A channel output	K	
B	/A channel output	L	
C	B channel output	M	
D	/B channel output	N	
E	Z channel output	P	
F	/Z channel output	R	Reset
G	0V	S	0V (battery)
H	+5V DC	T	3.6V (battery)
J	FG (Frame Ground)		

Note 1) Terminals K to P are not used. Do not connect anything.

2) Receptacle, plug and cable clamp are common regardless of motor capacity.

• Connector Wiring on Motor Side



A	Phase U
B	Phase V
C	Phase W
D	Ground terminal

Note Receptacle, plug and cable clamp differ depending on the capacity. Refer to 6) Connectors on Detector and Motor Sides (page 392).

www.repairtw.com

Absolute encoder (15bit : 8192 P/R, 12 bit : 1024 P/R), with brake

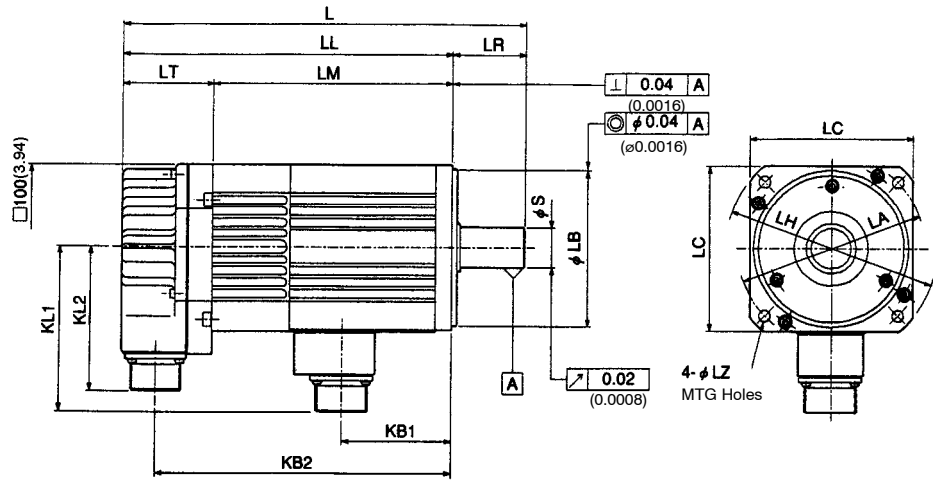

Detailed View of Shaft End

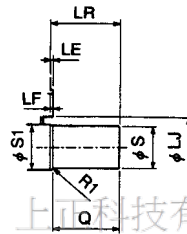

5

上海科技有限公司

購買、維修 此手冊零組件

電話： 037-466333

in mm (inches)

Type SGMS-	L	LL	LM	LR	LT	KB1	KB2	KL1	KL2
10ASAAB	252 (9.92)	207 (8.15)	147 (5.79)	45 (1.77)	60 (2.36)	67 (2.64)	186 (7.32)	100 (3.94)	87 (3.43)
15ASAAB	278 (10.94)	233 (9.17)	173 (6.81)	45 (1.77)	60 (2.36)	93 (3.66)	212 (8.35)	100 (3.94)	87 (3.43)
20ASAAB	301 (11.85)	256 (10.08)	196 (7.72)	45 (1.77)	60 (2.36)	116 (4.57)	235 (9.25)	100 (3.94)	87 (3.43)
30ASAAB	314 (12.36)	251 (9.88)	191 (7.52)	63 (2.48)	60 (2.36)	113 (4.45)	230 (9.06)	119 (4.69)	87 (3.43)
40ASAAB	350 (13.78)	288 (11.34)	228 (8.98)	63 (2.48)	60 (2.36)	150 (5.91)	267 (10.51)	119 (4.69)	87 (3.43)
50ASAAB	391 (15.39)	328 (12.91)	268 (10.55)	63 (2.48)	60 (2.36)	190 (7.48)	307 (12.09)	119 (4.69)	87 (3.43)

in mm (inches)

Type SGMS-	Flange dimensions								
	LA	LB	LC	LE	LF	LG	LH	LJ	LZ
10ASAAB	115 (4.53)	$95 \begin{matrix} 0 \\ - 0.035 \\ 0 \\ (3.74 - 0.0014) \end{matrix}$	100 (3.94)	3 (0.12)	3 (0.12)	10 (0.39)	130 (5.12)	45 (1.77)	7 (0.28)
15ASAAB	115 (4.53)	$95 \begin{matrix} 0 \\ - 0.035 \\ 0 \\ (3.74 - 0.0014) \end{matrix}$	100 (3.94)	3 (0.12)	3 (0.12)	10 (0.39)	130 (5.12)	45 (1.77)	7 (0.28)
20ASAAB	115 (4.53)	$95 \begin{matrix} 0 \\ - 0.035 \\ 0 \\ (3.74 - 0.0014) \end{matrix}$	100 (3.94)	3 (0.12)	3 (0.12)	10 (0.39)	130 (5.12)	45 (1.77)	7 (0.28)
30ASAAB	145 (5.71)	$110 \begin{matrix} 0 \\ - 0.035 \\ 0 \\ (4.33 - 0.0014) \end{matrix}$	130 (5.12)	6 (0.24)	6 (0.24)	12 (0.47)	165 (6.50)	45 (1.77)	9 (0.35)
40ASAAB	145 (5.71)	$110 \begin{matrix} 0 \\ - 0.035 \\ 0 \\ (4.33 - 0.0014) \end{matrix}$	130 (5.12)	6 (0.24)	6 (0.24)	12 (0.47)	165 (6.50)	45 (1.77)	9 (0.35)
50ASAAB	145 (5.71)	$110 \begin{matrix} 0 \\ - 0.035 \\ 0 \\ (4.33 - 0.0014) \end{matrix}$	130 (5.12)	6 (0.24)	6 (0.24)	12 (0.47)	165 (6.50)	45 (1.77)	9 (0.35)

上正科技有限公司

購買、維修 此手冊零組件

電話： 037-466333

Email: service@repairtw.com

Line id: @zzzz

www.repairtw.com

USING THE DIGITAL OPERATOR

5.4.1 Servomotor Dimensional Drawings cont.

in mm (inches)

Type SGMS-	Shaft end dimensions			Approx. mass kg (lb)
	S	S1	Q	
10ASAAB	$24 \begin{smallmatrix} 0 \\ - 0.013 \\ 0 \\ (0.94 - 0.0005) \end{smallmatrix}$	30 (1.18)	40 (1.57)	6.5 (14.33)
15ASAAB	$24 \begin{smallmatrix} 0 \\ - 0.013 \\ 0 \\ (0.94 - 0.0005) \end{smallmatrix}$	30 (1.18)	40 (1.57)	8.0 (17.63)
20ASAAB	$24 \begin{smallmatrix} 0 \\ - 0.013 \\ 0 \\ (0.94 - 0.0005) \end{smallmatrix}$	30 (1.18)	40 (1.57)	9.0 (19.84)
30ASAAB	$28 \begin{smallmatrix} 0 \\ - 0.013 \\ 0 \\ (1.10 - 0.0005) \end{smallmatrix}$	30 (1.18)	55 (2.17)	14.5 (31.96)
40ASAAB	$28 \begin{smallmatrix} 0 \\ - 0.013 \\ 0 \\ (1.10 - 0.0005) \end{smallmatrix}$	30 (1.18)	55 (2.17)	17.5 (38.57)
50ASAAB	$28 \begin{smallmatrix} 0 \\ - 0.013 \\ 0 \\ (1.10 - 0.0005) \end{smallmatrix}$	30 (1.18)	55 (2.17)	20.5 (45.18)

Note Absolute encoder (15bit : 8192 P/R) is used as a detector.

- Connector Wiring on Motor Side 037-466333

Email: service@repairtw.com
Motor Wiring Specifications

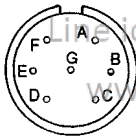

A	Phase U	E	Brake terminal
B	Phase V	F	Brake terminal
C	Phase W	G	-
D	Frame ground (FG)		

Low backlash gear (3000 min⁻¹), without brake

- Flange-mounted type

Grease-lubrication type small size servomotors

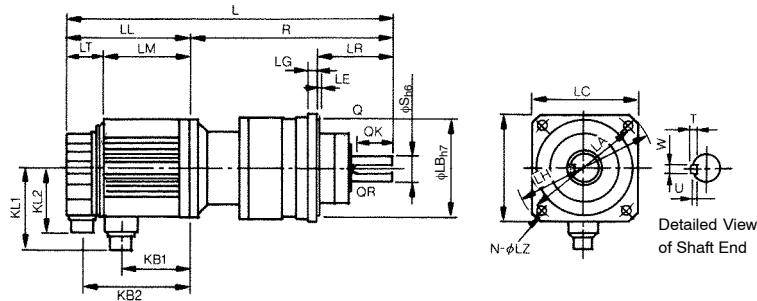

in mm (inches)

Motor type SGMS-	Gear type	Gear ratio	L	LL	LM	LR	LT	KB1	KB2	KL1	KL2	R	Shaft center allowable radial load N	Approx. mass kg (lb)
10A6AL1K	BL2	1/5	403 (15.9)	149 (5.87)	103 (4.06)	100 (3.94)	46 (1.81)	76 (2.99)	128 (5.04)	96 (3.78)	87 (3.43)	254 (10.0)	833	13 (28.7)
10A6AL2K		1/9	415 (16.3)	149 (5.87)	103 (4.06)	100 (3.94)	46 (1.81)	76 (2.99)	128 (5.04)	96 (3.78)	87 (3.43)	266 (10.5)	980	13 (28.7)
15A6AL1K	BL2	1/5	429 (16.9)	175 (6.89)	129 (5.08)	100 (3.94)	46 (1.81)	102 (4.02)	154 (6.06)	96 (3.78)	87 (3.43)	254 (10.0)	833	14 (30.9)
20A6AL1K	BL2	1/5	452 (17.8)	198 (7.80)	152 (5.98)	100 (3.94)	46 (1.81)	125 (4.92)	177 (6.97)	96 (3.78)	87 (3.43)	254 (10.0)	833	15 (33.1)

購買、維修 此手冊零組件

in mm (inches)

Motor type SGMS-	Flange dimensions							Shaft end dimensions							
	LA	LB	LC	LE	LG	LH	N	LZ	S	Q	QK	QR	T	U	W
10A6AL1K	160 (6.30)	130 ⁰ _{-0.040} (5.12 ⁰ _{-0.0016})	140 (5.51)	3 (0.12)	12 (0.47)	185 (7.28)	4	12 (0.47)	35 ⁰ _{-0.016} (1.38 ⁰ _{-0.0006})	55 (2.17)	47 (1.85)	1 (0.039)	8 (0.31)	5 (0.20)	10 (0.39)
10A6AL2K	160 (6.30)	130 ⁰ _{-0.040} (5.12 ⁰ _{-0.0016})	140 (5.51)	3 (0.12)	12 (0.47)	185 (7.28)	4	12 (0.47)	35 ⁰ _{-0.016} (1.38 ⁰ _{-0.0006})	55 (2.17)	47 (1.85)	1 (0.039)	8 (0.31)	5 (0.20)	10 (0.39)
15A6AL1K	160 (6.30)	130 ⁰ _{-0.040} (5.12 ⁰ _{-0.0016})	140 (5.51)	3 (0.12)	12 (0.47)	185 (7.28)	4	12 (0.47)	35 ⁰ _{-0.016} (1.38 ⁰ _{-0.0006})	55 (2.17)	47 (1.85)	1 (0.039)	8 (0.31)	5 (0.20)	10 (0.39)
20A6AL1K	160 (6.30)	130 ⁰ _{-0.040} (5.12 ⁰ _{-0.0016})	140 (5.51)	3 (0.12)	12 (0.47)	185 (7.28)	4	12 (0.47)	35 ⁰ _{-0.016} (1.38 ⁰ _{-0.0006})	55 (2.17)	47 (1.85)	1 (0.039)	8 (0.31)	5 (0.20)	10 (0.39)

5

Grease-lubrication type large size servomotors

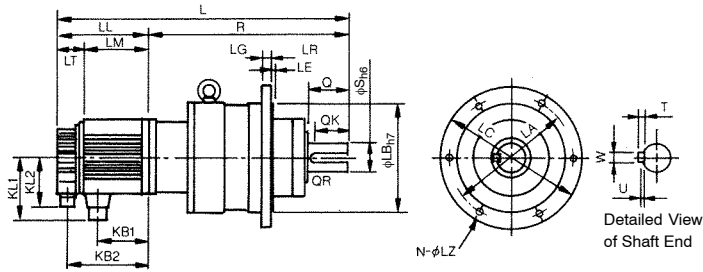

in mm (inches)

Motor type SGMS-	Gear type	Gear ratio	L	LL	LM	LR	LT	KB1	KB2	KL1	KL2	R	Shaft center allowable radial load N	Approx. mass kg (lb)
10A6AL5K	BL3	1/20	496 (19.5)	149 (5.87)	103 (4.06)	140 (5.51)	46 (1.81)	76 (2.99)	128 (5.04)	96 (3.78)	87 (3.43)	347 (13.7)	2650	30 (66.1)
10A6AL7K		1/29	496 (19.5)	149 (5.87)	103 (4.06)	140 (5.51)	46 (1.81)	76 (2.99)	128 (5.04)	96 (3.78)	87 (3.43)	347 (13.7)	2940	30 (66.1)
10A6AL8K		1/45	506 (19.9)	149 (5.87)	103 (4.06)	140 (5.51)	46 (1.81)	76 (2.99)	128 (5.04)	96 (3.78)	87 (3.43)	357 (14.1)	3430	30 (66.1)
15A6AL2K	BL3	1/9	518 (20.4)	175 (6.89)	129 (5.08)	140 (5.51)	46 (1.81)	102 (4.02)	154 (6.06)	96 (3.78)	87 (3.43)	343 (13.5)	1960	31 (68.3)
15A6AL5K		1/20	522 (20.6)	175 (6.89)	129 (5.08)	140 (5.51)	46 (1.81)	102 (4.02)	154 (6.06)	96 (3.78)	87 (3.43)	347 (13.7)	2650	31 (68.3)
15A6AL7K		1/29	522 (20.6)	175 (6.89)	129 (5.08)	140 (5.51)	46 (1.81)	102 (4.02)	154 (6.06)	96 (3.78)	87 (3.43)	347 (13.7)	2940	31 (68.3)
15A6AL8K	BL4	1/45	573 (22.6)	175 (6.89)	129 (5.08)	160 (6.30)	46 (1.81)	102 (4.02)	154 (6.06)	96 (3.78)	87 (3.43)	398 (15.7)	8040	51 (112.4)
20A6AL2K	BL3	1/9	541 (21.3)	198 (7.80)	152 (5.98)	140 (5.51)	46 (1.81)	125 (4.92)	177 (6.97)	96 (3.78)	87 (3.43)	343 (13.5)	1960	32 (70.5)
20A6AL5K		1/20	545 (21.5)	198 (7.80)	152 (5.98)	140 (5.51)	46 (1.81)	125 (4.92)	177 (6.97)	96 (3.78)	87 (3.43)	347 (13.7)	2650	32 (70.5)
20A6AL7K	BL4	1/29	586 (23.1)	198 (7.80)	152 (5.98)	160 (6.30)	46 (1.81)	125 (4.92)	177 (6.97)	96 (3.78)	87 (3.43)	388 (15.3)	6860	52 (114.6)
20A6AL8K		1/45	596 (23.5)	198 (7.80)	152 (5.98)	160 (6.30)	46 (1.81)	125 (4.92)	177 (6.97)	96 (3.78)	87 (3.43)	398 (15.7)	8040	52 (114.6)
30A6AL1K	BL3	1/5	540 (21.3)	199 (7.83)	153 (6.02)	140 (5.51)	46 (1.81)	122 (4.80)	178 (7.01)	114 (4.49)	87 (3.43)	341 (13.4)	1670	29 (63.9)
30A6AL2K		1/9	567 (22.3)	199 (7.83)	153 (6.02)	140 (5.51)	46 (1.81)	122 (4.80)	178 (7.01)	114 (4.49)	87 (3.43)	368 (14.5)	1960	36 (79.4)
30A6AL5K	BL4	1/20	612 (24.1)	199 (7.83)	153 (6.02)	160 (6.30)	46 (1.81)	122 (4.80)	178 (7.01)	114 (4.49)	87 (3.43)	413 (16.3)	6080	56 (123.5)
30A6AL7K		1/29	612 (24.1)	199 (7.83)	153 (6.02)	160 (6.30)	46 (1.81)	122 (4.80)	178 (7.01)	114 (4.49)	87 (3.43)	413 (16.3)	6860	56 (123.5)
30A6AL8K		1/45	622 (24.5)	199 (7.83)	153 (6.02)	160 (6.30)	46 (1.81)	122 (4.80)	178 (7.01)	114 (4.49)	87 (3.43)	423 (16.7)	8040	56 (123.5)
40A6AL1K	BL3	1/5	577 (22.7)	236 (9.29)	190 (7.48)	140 (5.51)	46 (1.81)	159 (6.26)	215 (8.46)	114 (4.49)	87 (3.43)	341 (13.4)	1670	32 (70.5)
40A6AL2K	BL4	1/9	649 (25.6)	236 (9.29)	190 (7.48)	160 (6.30)	46 (1.81)	159 (6.26)	215 (8.46)	114 (4.49)	87 (3.43)	413 (16.3)	4700	59 (130.1)
40A6AL5K		1/20	649 (25.6)	236 (9.29)	190 (7.48)	160 (6.30)	46 (1.81)	159 (6.26)	215 (8.46)	114 (4.49)	87 (3.43)	413 (16.3)	6080	59 (130.1)
40A6AL7K		1/29	649 (25.6)	236 (9.29)	190 (7.48)	160 (6.30)	46 (1.81)	159 (6.26)	215 (8.46)	114 (4.49)	87 (3.43)	413 (16.3)	6860	59 (130.1)

Motor type SGMS-	Gear type	Gear ratio	L	LL	LM	LR	LT	KB1	KB2	KL1	KL2	R	Shaft center allowable radial load N	Approx. mass kg (lb)
50A6AL1K	BL4	1/5	657 (25.9)	276 (10.9)	230 (9.06)	160 (6.30)	46 (1.81)	199 (7.83)	255 (10.0)	114 (4.49)	87 (3.43)	381 (15.0)	3820	52 (114.6)
50A6AL2K		1/9	689 (27.1)	276 (10.9)	230 (9.06)	160 (6.30)	46 (1.81)	199 (7.83)	255 (10.0)	114 (4.49)	87 (3.43)	413 (16.3)	4700	62 (136.8)
50A6AL5K		1/20	689 (27.1)	276 (10.9)	230 (9.06)	160 (6.30)	46 (1.81)	199 (7.83)	255 (10.0)	114 (4.49)	87 (3.43)	413 (16.3)	6080	62 (136.8)

in mm (inches)

Motor type SGMS-	Frange dimensions							Shaft end dimensions						
	LA	LB	LC	LE	LG	N	LZ	S	Q	QK	QR	T	U	W
10A6AL5K	220 (8.66)	190 ⁰ _{-0.046} (7.48 ⁰ _{-0.0018})	245 (9.65)	5 (0.20)	15 (0.59)	6	12 (0.47)	50 ⁰ _{-0.016} (1.97 ⁰ _{-0.0006})	75 (2.95)	65 (2.56)	1 (0.039)	9 (0.35)	5.5 (0.22)	14 (0.55)
10A6AL7K	220 (8.66)	190 ⁰ _{-0.046} (7.48 ⁰ _{-0.0018})	245 (9.65)	5 (0.20)	15 (0.59)	6	12 (0.47)	50 ⁰ _{-0.016} (1.97 ⁰ _{-0.0006})	75 (2.95)	65 (2.56)	1 (0.039)	9 (0.35)	5.5 (0.22)	14 (0.55)
10A6AL8K	220 (8.66)	190 ⁰ _{-0.046} (7.48 ⁰ _{-0.0018})	245 (9.65)	5 (0.20)	15 (0.59)	6	12 (0.47)	50 ⁰ _{-0.016} (1.97 ⁰ _{-0.0006})	75 (2.95)	65 (2.56)	1 (0.039)	9 (0.35)	5.5 (0.22)	14 (0.55)
15A6AL2K	220 (8.66)	190 ⁰ _{-0.046} (7.48 ⁰ _{-0.0018})	245 (9.65)	5 (0.20)	15 (0.59)	6	12 (0.47)	50 ⁰ _{-0.016} (1.97 ⁰ _{-0.0006})	75 (2.95)	65 (2.56)	1 (0.039)	9 (0.35)	5.5 (0.22)	14 (0.55)
15A6AL5K	220 (8.66)	190 ⁰ _{-0.046} (7.48 ⁰ _{-0.0018})	245 (9.65)	5 (0.20)	15 (0.59)	6	12 (0.47)	50 ⁰ _{-0.016} (1.97 ⁰ _{-0.0006})	75 (2.95)	65 (2.56)	1 (0.039)	9 (0.35)	5.5 (0.22)	14 (0.55)
15A6AL7K	220 (8.66)	190 ⁰ _{-0.046} (7.48 ⁰ _{-0.0018})	245 (9.65)	5 (0.20)	15 (0.59)	6	12 (0.47)	50 ⁰ _{-0.016} (1.97 ⁰ _{-0.0006})	75 (2.95)	65 (2.56)	1 (0.039)	9 (0.35)	5.5 (0.22)	14 (0.55)
15A6AL8K	280 (11.0)	240 ⁰ _{-0.046} (9.45 ⁰ _{-0.0018})	310 (12.2)	5 (0.20)	18 (0.71)	6	14 (0.55)	60 ⁰ _{-0.019} (2.36 ⁰ _{-0.0007})	90 (3.54)	78 (3.07)	1 (0.039)	11 (0.43)	7 (0.28)	18 (0.71)
20A6AL2K	220 (8.66)	190 ⁰ _{-0.046} (7.48 ⁰ _{-0.0018})	245 (9.65)	5 (0.20)	15 (0.59)	6	12 (0.47)	50 ⁰ _{-0.016} (1.97 ⁰ _{-0.0006})	75 (2.95)	65 (2.56)	1 (0.039)	9 (0.35)	5.5 (0.22)	14 (0.55)
20A6AL5K	220 (8.66)	190 ⁰ _{-0.046} (7.48 ⁰ _{-0.0018})	245 (9.65)	5 (0.20)	15 (0.59)	6	12 (0.47)	50 ⁰ _{-0.016} (1.97 ⁰ _{-0.0006})	75 (2.95)	65 (2.56)	1 (0.039)	9 (0.35)	5.5 (0.22)	14 (0.55)
20A6AL7K	280 (11.0)	240 ⁰ _{-0.046} (9.45 ⁰ _{-0.0018})	310 (12.2)	5 (0.20)	18 (0.71)	6	14 (0.55)	60 ⁰ _{-0.019} (2.36 ⁰ _{-0.0007})	90 (3.54)	78 (3.07)	1 (0.039)	11 (0.43)	7 (0.28)	18 (0.71)
20A6AL8K	280 (11.0)	240 ⁰ _{-0.046} (9.45 ⁰ _{-0.0018})	310 (12.2)	5 (0.20)	18 (0.71)	6	14 (0.55)	60 ⁰ _{-0.019} (2.36 ⁰ _{-0.0007})	90 (3.54)	78 (3.07)	1 (0.039)	11 (0.43)	7 (0.28)	18 (0.71)
30A6AL1K	220 (8.66)	190 ⁰ _{-0.046} (7.48 ⁰ _{-0.0018})	245 (9.65)	5 (0.20)	15 (0.59)	6	12 (0.47)	50 ⁰ _{-0.016} (1.97 ⁰ _{-0.0006})	75 (2.95)	65 (2.56)	1 (0.039)	9 (0.35)	5.5 (0.22)	14 (0.55)
30A6AL2K	220 (8.66)	190 ⁰ _{-0.046} (7.48 ⁰ _{-0.0018})	245 (9.65)	5 (0.20)	15 (0.59)	6	12 (0.47)	50 ⁰ _{-0.016} (1.97 ⁰ _{-0.0006})	75 (2.95)	65 (2.56)	1 (0.039)	9 (0.35)	5.5 (0.22)	14 (0.55)
30A6AL5K	280 (11.0)	240 ⁰ _{-0.046} (9.45 ⁰ _{-0.0018})	310 (12.2)	5 (0.20)	18 (0.71)	6	14 (0.55)	60 ⁰ _{-0.019} (2.36 ⁰ _{-0.0007})	90 (3.54)	78 (3.07)	1 (0.039)	11 (0.43)	7 (0.28)	18 (0.71)
30A6AL7K	280 (11.0)	240 ⁰ _{-0.046} (9.45 ⁰ _{-0.0018})	310 (12.2)	5 (0.20)	18 (0.71)	6	14 (0.55)	60 ⁰ _{-0.019} (2.36 ⁰ _{-0.0007})	90 (3.54)	78 (3.07)	1 (0.039)	11 (0.43)	7 (0.28)	18 (0.71)
30A6AL8K	280 (11.0)	240 ⁰ _{-0.046} (9.45 ⁰ _{-0.0018})	310 (12.2)	5 (0.20)	18 (0.71)	6	14 (0.55)	60 ⁰ _{-0.019} (2.36 ⁰ _{-0.0007})	90 (3.54)	78 (3.07)	1 (0.039)	11 (0.43)	7 (0.28)	18 (0.71)

5

USING THE DIGITAL OPERATOR

5.4.1 Servomotor Dimensional Drawings cont.

Motor type SGMS-	Frange dimensions							Shaft end dimensions						
	LA	LB	LC	LE	LG	N	LZ	S	Q	QK	QR	T	U	W
40A6AL1K	220 (8.66)	$190 \begin{smallmatrix} 0 \\ -0.046 \\ 0 \end{smallmatrix}$ $(7.48 \begin{smallmatrix} 0 \\ -0.0018 \end{smallmatrix})$	245 (9.65)	5 (0.20)	15 (0.59)	6	12 (0.47)	$50 \begin{smallmatrix} 0 \\ -0.016 \\ 0 \end{smallmatrix}$ $(1.97 \begin{smallmatrix} 0 \\ -0.0006 \end{smallmatrix})$	75 (2.95)	65 (2.56)	1 (0.039)	9 (0.35)	5.5 (0.22)	14 (0.55)
40A6AL2K	280 (11.0)	$240 \begin{smallmatrix} 0 \\ -0.046 \\ 0 \end{smallmatrix}$ $(9.45 \begin{smallmatrix} 0 \\ -0.0018 \end{smallmatrix})$	310 (12.2)	5 (0.20)	18 (0.71)	6	14 (0.55)	$60 \begin{smallmatrix} 0 \\ -0.019 \\ 0 \end{smallmatrix}$ $(2.36 \begin{smallmatrix} 0 \\ -0.0007 \end{smallmatrix})$	90 (3.54)	78 (3.07)	1 (0.039)	11 (0.43)	7 (0.28)	18 (0.71)
40A6AL5K	280 (11.0)	$240 \begin{smallmatrix} 0 \\ -0.046 \\ 0 \end{smallmatrix}$ $(9.45 \begin{smallmatrix} 0 \\ -0.0018 \end{smallmatrix})$	310 (12.2)	5 (0.20)	18 (0.71)	6	14 (0.55)	$60 \begin{smallmatrix} 0 \\ -0.019 \\ 0 \end{smallmatrix}$ $(2.36 \begin{smallmatrix} 0 \\ -0.0007 \end{smallmatrix})$	90 (3.54)	78 (3.07)	1 (0.039)	11 (0.43)	7 (0.28)	18 (0.71)
40A6AL7K	280 (11.0)	$240 \begin{smallmatrix} 0 \\ -0.046 \\ 0 \end{smallmatrix}$ $(9.45 \begin{smallmatrix} 0 \\ -0.0018 \end{smallmatrix})$	310 (12.2)	5 (0.20)	18 (0.71)	6	14 (0.55)	$60 \begin{smallmatrix} 0 \\ -0.019 \\ 0 \end{smallmatrix}$ $(2.36 \begin{smallmatrix} 0 \\ -0.0007 \end{smallmatrix})$	90 (3.54)	78 (3.07)	1 (0.039)	11 (0.43)	7 (0.28)	18 (0.71)
50A6AL1K	280 (11.0)	$240 \begin{smallmatrix} 0 \\ -0.046 \\ 0 \end{smallmatrix}$ $(9.45 \begin{smallmatrix} 0 \\ -0.0018 \end{smallmatrix})$	310 (12.2)	5 (0.20)	18 (0.71)	6	14 (0.55)	$60 \begin{smallmatrix} 0 \\ -0.019 \\ 0 \end{smallmatrix}$ $(2.36 \begin{smallmatrix} 0 \\ -0.0007 \end{smallmatrix})$	90 (3.54)	78 (3.07)	1 (0.039)	11 (0.43)	7 (0.28)	18 (0.71)
50A6AL2K	280 (11.0)	$240 \begin{smallmatrix} 0 \\ -0.046 \\ 0 \end{smallmatrix}$ $(9.45 \begin{smallmatrix} 0 \\ -0.0018 \end{smallmatrix})$	310 (12.2)	5 (0.20)	18 (0.71)	6	14 (0.55)	$60 \begin{smallmatrix} 0 \\ -0.019 \\ 0 \end{smallmatrix}$ $(2.36 \begin{smallmatrix} 0 \\ -0.0007 \end{smallmatrix})$	90 (3.54)	78 (3.07)	1 (0.039)	11 (0.43)	7 (0.28)	18 (0.71)
50A6AL5K	280 (11.0)	$240 \begin{smallmatrix} 0 \\ -0.046 \\ 0 \end{smallmatrix}$ $(9.45 \begin{smallmatrix} 0 \\ -0.0018 \end{smallmatrix})$	310 (12.2)	5 (0.20)	18 (0.71)	6	14 (0.55)	$60 \begin{smallmatrix} 0 \\ -0.019 \\ 0 \end{smallmatrix}$ $(2.36 \begin{smallmatrix} 0 \\ -0.0007 \end{smallmatrix})$	90 (3.54)	78 (3.07)	1 (0.039)	11 (0.43)	7 (0.28)	18 (0.71)

上正科技有限公司

購買、維修 此手冊零組件

電話： 037-466333

Email: service@repairtw.com

Line id: @zzzz

www.repairtw.com

Shaft end tap specifications

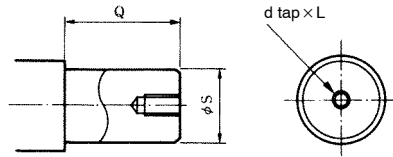

in mm (inches)

Gear type	Shaft diameter S	Shaft length Q	d × L
BL2	35 (1.38)	55 (2.17)	M8 × 16
BL3	50 (1.97)	75 (2.95)	M10 × 20
BL4	60 (2.36)	90 (3.54)	M12 × 24

Detailed dimensions of IMT gear

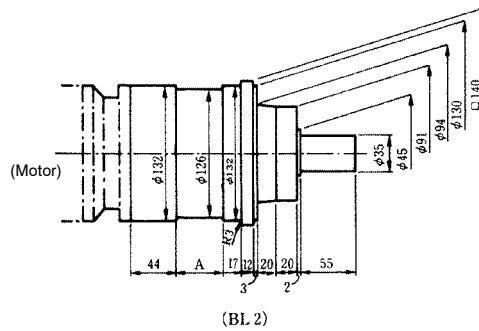

in mm (inches)

Gear ratio	A
1/5	6 (0.24)
1/9	18 (0.71)
1/20, 1/29	39 (1.54)
1/45	47 (1.85)

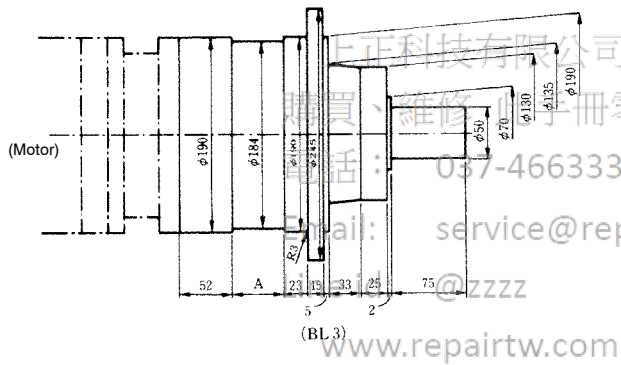

in mm (inches)

Gear ratio	A
1/5	11 (0.43)
1/9	38 (1.50)
1/20, 1/29	46 (1.81)
1/45	52 (2.05)

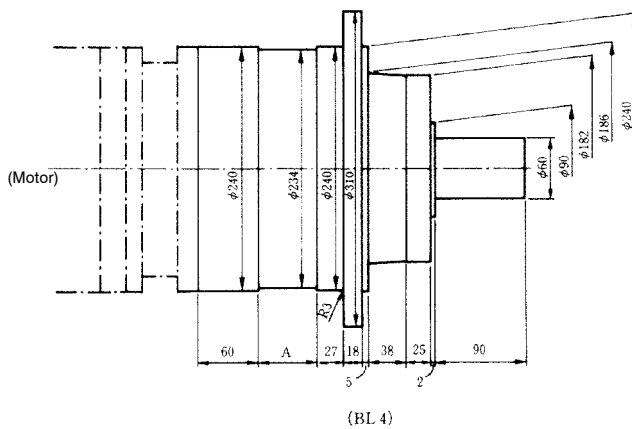

in mm (inches)

Gear ratio	A
1/5	16 (0.63)
1/9	48 (1.89)
1/20, 1/29	55 (2.17)
1/45	58 (2.28)

■ SGMD-□□A Servomotor

- Incremental encoder (4096 P/R)
- Incremental encoder (4096 P/R), with brake

The dimensional drawing is the same for these types. Only approximate mass differs.

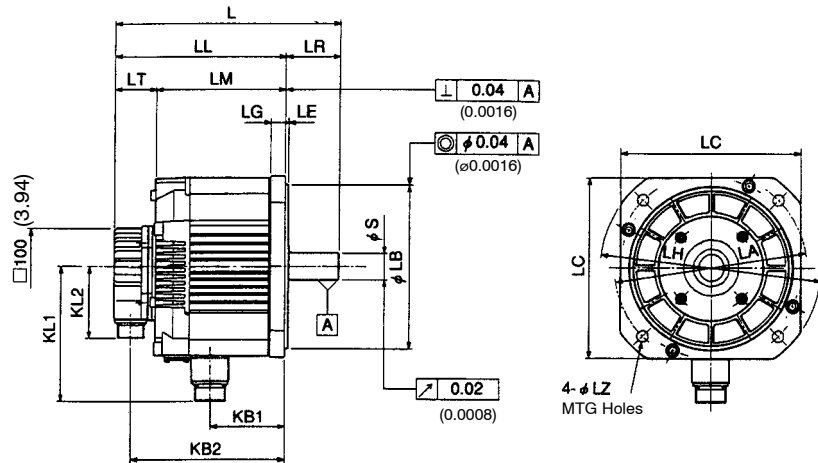

Detailed View of Shaft End

5

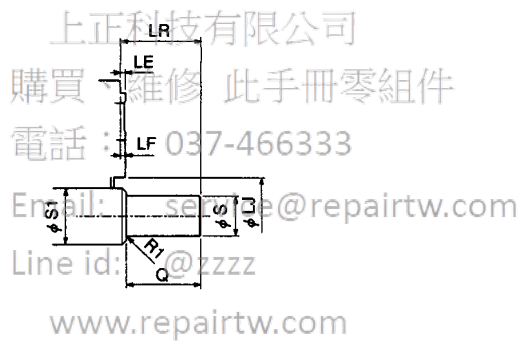

in mm (inches)

Type SGMD-	L	LL	LM	LR	LT	KB1	KB2	KL1	KL2
22A6A	242 (9.53)	187 (7.36)	144 (5.67)	55 (2.17)	43 (1.69)	70 (2.76)	166 (6.54)	165 (6.50)	88 (3.46)
32A6A	254 (10.00)	199 (7.83)	156 (6.14)	55 (2.17)	43 (1.69)	82 (3.23)	178 (7.01)	165 (6.50)	88 (3.46)
40A6A	274 (10.79)	209 (8.23)	166 (6.54)	65 (2.56)	43 (1.69)	92 (3.62)	188 (7.40)	165 (6.50)	88 (3.46)

in mm (inches)

Type SGMD-	Flange dimensions								
	LA	LB	LC	LE	LF	LG	LH	LJ	LZ
22A6A	235 (9.25)	200 ⁰ _{-0.046} (7.87 ⁰ _{-0.0018})	220 (8.66)	4 (0.16)	4 (0.16)	18 (0.71)	270 (10.63)	62 (2.44)	13.5 (0.53)
32A6A	235 (9.25)	200 ⁰ _{-0.046} (7.87 ⁰ _{-0.0018})	220 (8.66)	4 (0.16)	4 (0.16)	18 (0.71)	270 (10.63)	62 (2.44)	13.5 (0.53)
40A6A	235 (9.25)	200 ⁰ _{-0.046} (7.87 ⁰ _{-0.0018})	220 (8.66)	4 (0.16)	4 (0.16)	18 (0.71)	270 (10.63)	62 (2.44)	13.5 (0.53)

in mm (inches)

Type SGMD-	Shaft end dimensions			Approx. mass kg (lb)	
	S	S1	Q	without brake	with brake
22A6A	28 ⁰ _{-0.013} (1.10 ⁰ _{-0.0005})	45 (1.77)	50 (1.97)	15.5 (34.16)	20.5 (45.18)
32A6A	28 ⁰ _{-0.013} (1.10 ⁰ _{-0.0005})	45 (1.77)	50 (1.97)	18.5 (40.77)	23.5 (51.79)
40A6A	32 ⁰ _{-0.016} (1.26 ⁰ _{-0.0006})	45 (1.77)	60 (2.36)	21 (46.28)	26 (57.30)

Email: service@repairtw.com**Note** 1) Incremental encoder (4096 P/R) is used as a detector.

2) For SGMD servomotors with brake, the product type code ends with "AB".

• Connector Wiring on Detector Side

Receptacle: MS3102A20-29P

Plug (To be prepared by customer) (L type): MS3108B20-29S or (Straight type) MS3106B20-29S

Cable Clamp: (To be prepared by customer) MS3057-12A

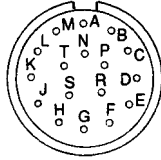

Encoder Wiring Specifications

A	A channel output	K	
B	/A channel output	L	
C	B channel output	M	
D	/B channel output	N	
E	C channel output	P	
F	/C channel output	R	
G	0V	S	
H	+5V DC	T	
J	FG (Frame Ground)		

Note 1) Terminals K to T are not used.

2) Receptacle, plug and cable clamp are common regardless of motor capacity.

• Connector Wiring on Motor Side

Receptacle: MS3102A24-10P

Plug (To be prepared by customer) (L type): MS3108B24-10S or (Straight type) MS3106B24-10S

Cable Clamp: (To be prepared by customer) MS3057-16A



Motor Wiring Specifications

A	Phase U	E	Brake terminal
B	Phase V	F	Brake terminal
C	Phase W	G	-
D	Frame ground (FG)		

Note E,F are only used with the brake.

Absolute encoder (12-bit : 1024 P/R)
Absolute encoder (12-bit : 1024 P/R), with brake

These dimensional drawing is the same for these types. Only approximate mass differs.

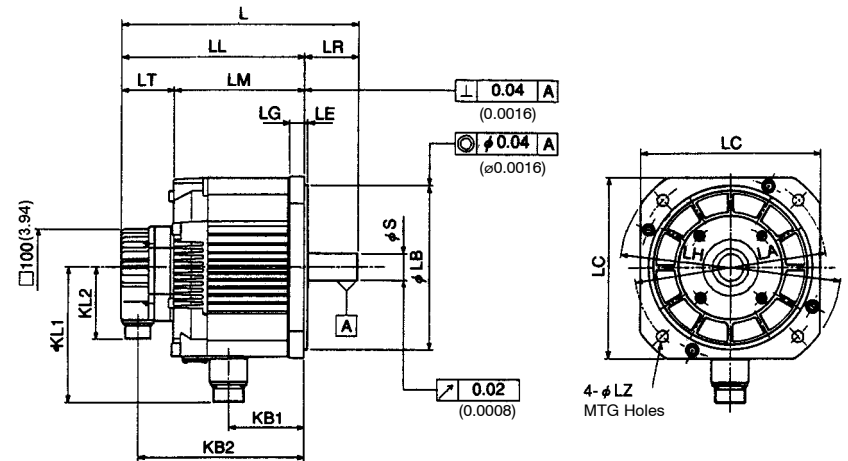

Detailed View of Shaft End

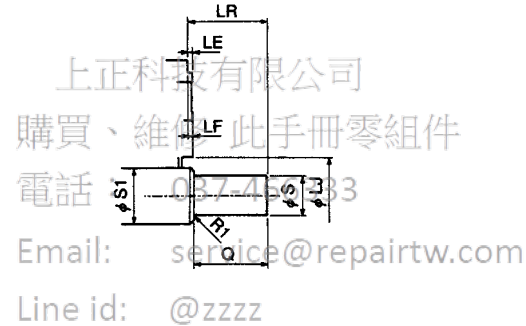

www.repairtw.com

in mm (inches)

Type SGMG-	L	LL	LM	LR	LT	KB1	KB2	KL1	KL2
22AWA	256 (10.08)	201 (7.91)	144 (5.67)	55 (2.17)	57 (2.24)	70 (2.76)	180 (7.09)	165 (6.50)	88 (3.46)
32AWA	268 (10.55)	213 (8.39)	156 (6.14)	55 (2.17)	57 (2.24)	82 (3.23)	192 (7.56)	165 (6.50)	88 (3.46)
40AWA	288 (11.34)	223 (8.78)	166 (6.54)	65 (2.56)	57 (2.24)	92 (3.62)	202 (7.95)	165 (6.50)	88 (3.46)

in mm (inches)

Type SGMG-	Flange dimensions								
	LA	LB	LC	LE	LF	LG	LH	LJ	LZ
22AWA	235 (9.25)	200 ⁰ - 0.046 (7.87 - 0.0018)	220 (8.66)	4 (0.16)	4 (0.16)	18 (0.71)	270 (10.63)	62 (2.44)	13.5 (0.53)
32AWA	235 (9.25)	200 ⁰ - 0.046 (7.87 - 0.0018)	220 (8.66)	4 (0.16)	4 (0.16)	18 (0.71)	270 (10.63)	62 (2.44)	13.5 (0.53)
40AWA	235 (9.25)	200 ⁰ - 0.046 (7.87 - 0.0018)	220 (8.66)	4 (0.16)	4 (0.16)	18 (0.71)	270 (10.63)	62 (2.44)	13.5 (0.53)

in mm (inches)

Type SGMG-	Shaft end dimensions			Approx. mass kg (lb)	
	S	S1	Q	without brake	with brake
22AWA	28 ⁰ - 0.013 (1.10 - 0.0005)	45 (1.77)	50 (1.97)	15.5 (34.16)	20.5 (45.18)
32AWA	28 ⁰ - 0.013 (1.10 - 0.0005)	45 (1.77)	50 (1.97)	18.5 (40.77)	23.5 (51.79)
40AWA	32 ⁰ - 0.016 (1.26 - 0.0006)	45 (1.77)	60 (2.36)	21 (46.28)	26.5 (58.41)

- Note**
- 1) Absolute encoder (12-bit : 1024 P/R) is used as a detector.
 - 2) For SGMD servomotors with brake, the product type code ends with "AB".

Email: service@repairtw.com
Line id: @zzzz

- Connector Wiring on Detector side

Receptacle: MS3102A20-29P

Plug (To be prepared by customer) (L type): MS3108B20-29S or
(Straight type) MS3106B20-29S

Cable Clamp: (To be prepared by customer) MS3057-12A

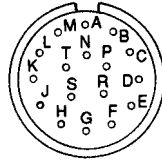

Encoder Wiring Specifications

A	A channel output	K	S channel output
B	/A channel output	L	/S channel output
C	B channel output	M	
D	/B channel output	N	
E	Z (C) channel output	P	
F	/Z (C) channel output	R	reset
G	0V	S	0V (battery)
H	+5V DC	T	3.6V (battery)
J	FG (Frame Ground)		

- Note**
- 1) Terminals M to P are not used. Do not connect anything.
 - 2) Receptacle, plug and cable clamp are common regardless of motor capacity.

- Connector Wiring on Motor side

Receptacle: MS3102A24-10P

Plug (To be prepared by customer) (L type): MS3108B24-10S or
(Straight type) MS3106B24-10S

Cable Clamp: (To be prepared by customer) MS3057-16A

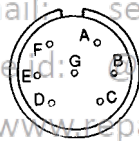

A	Phase U	E	Brake terminal
B	Phase V	F	Brake terminal
C	Phase W	G	-
D	Frame ground (FG)		

Note E,F are only used with the brake.

■ SGMP-15A Servomotor

SGMP Servomotor
Incremental Encoder without brake (SGMP-15A31 Servomotor)

• 1.5kW

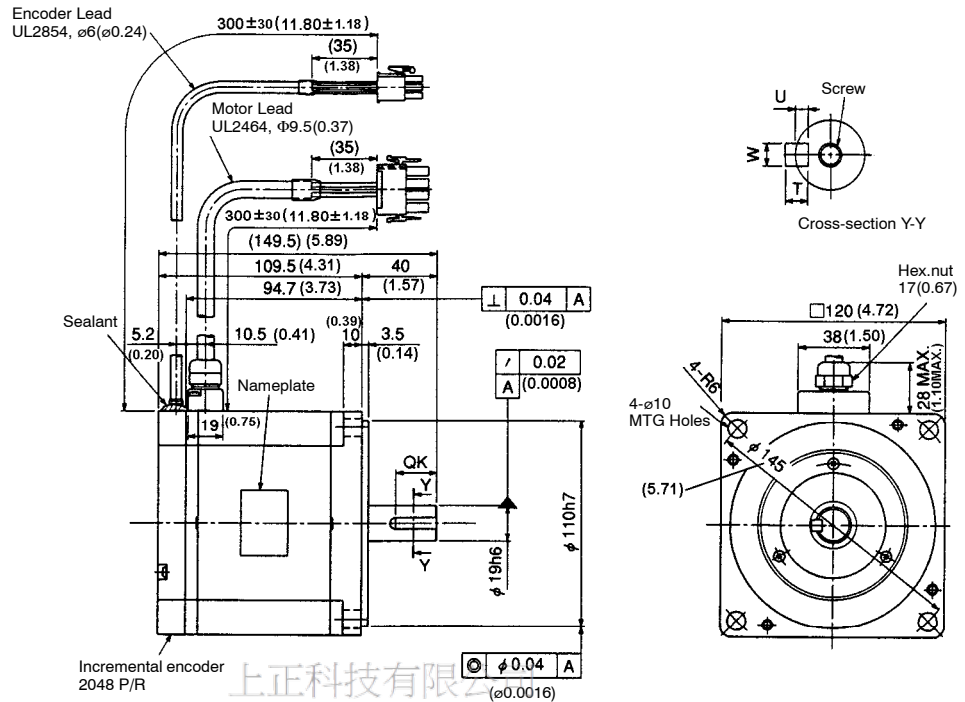

5

上正科技有限公司
 購買、維修 此手冊零組件

電話： 037-466333

in mm (inches)

Type SGMP-	QK	U	W	T	Screw Dimensions	Output W (HP)	Approx. mass kg (lb)	Allowable radial load N (lb)	Allowable thrust load N (lb)
15A312	No key				No Screw	1500 (2.02)	6.6 (14.55)	490 (110)	147 (33)
15A314	22 (0.87)	3.5 (0.14)	6 (0.24)	6 (0.24)	No Screw				
15A316	22 (0.87)	3.5 (0.14)	6 (0.24)	6 (0.24)	M6, depth 10				

- Note**
- 1) The detector uses an incremental encoder 2048 P/R.
 - 2) Type "A" indicates 200 V specification.
 - 3) "15A314" and "15A316" have a keyed shaft. The keyway complies with JIS B 1301-1976 (precision). A straight key is supplied.
 - 4) The quoted allowable radial load is the value at a position 35 mm (1.40 in.) from the motor mounting surface.

- Details of Motor and Encoder Plugs

Motor Plug

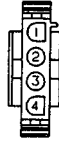

Plug : 350779-1 (Made by AMP)
 Pin: 350218-6 or 350547-6
 Connected to
 Cap: 350780-1
 Socket: 350536-6 or 350550-6

Motor Wiring Specifications

1	Phase U	Red
2	Phase V	White
3	Phase W	Blue
4	FG	Green/Yellow

Encoder Plug



Plug: 172169-1 (Made by AMP)
 Pin: 170359-1 or 170363-1
 Connected to
 Cap :172161-1
 Socket: 170361-1 or 170365-1

Incremental Encoder Wiring Specifications

1	A channel output	Blue
2	/A channel output	Blue/Black
3	B channel output	Yellow
4	/B channel output	Yellow/Black
5	C channel output	Green
6	/C channel output	Green/Black
7	0V (power supply)	Gray
8	+5V (power supply)	Red
9	FG (Frame Ground)	Orange

上正科技有限公司

購買、維修 此手冊零組件

電話： 037-466333

Email: service@repairtw.com

Line id: @zzzz

www.repairtw.com

SGMP Servomotor
Incremental Encoder with brake (SGMP-15A31□B, C Servomotor)

• 1.5kW

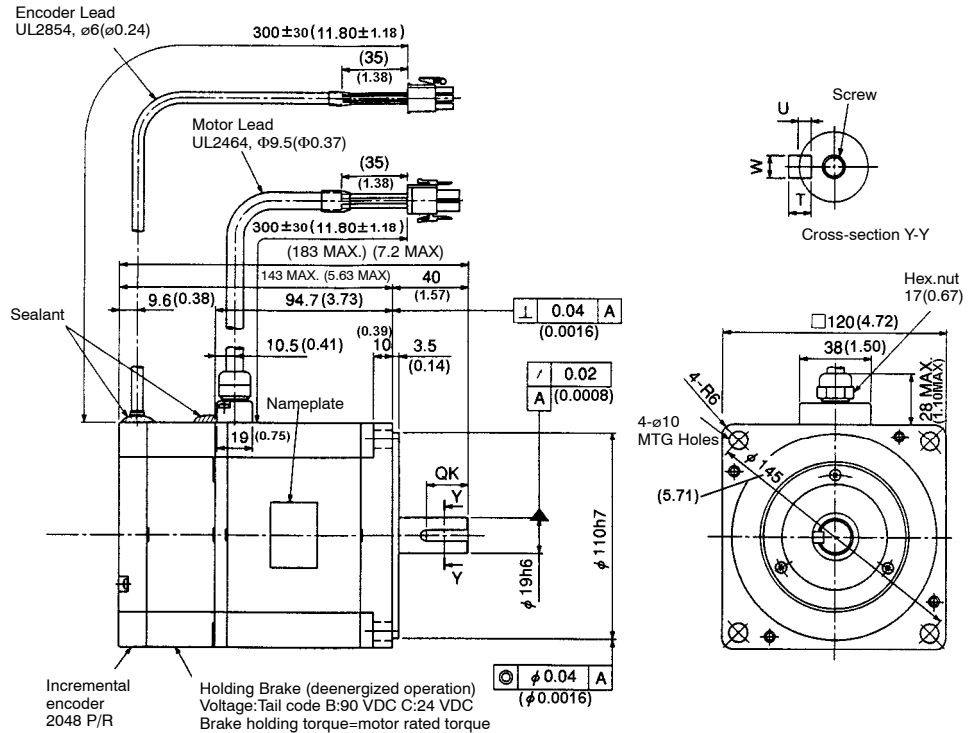

5

上正科技有限公司

購買、維修 此手冊零組件

in mm (inches)

Type SGMP-	QK	U	W	T	Screw Dimensions	Output W (HP)	Approx. mass kg (lb)	Allowable radial load N (lb)	Allowable thrust load N (lb)
15A312B	No key				No Screw	1500 (2.02)	8.1 (17.85)	490 (110)	147 (33)
15A312C					No Screw				
15A314B	22 (0.87)	3.5 (0.14)	6 (0.24)	6 (0.24)	No Screw	1500 (2.02)	8.1 (17.85)	490 (110)	147 (33)
15A314C					No Screw				
15A316B	22 (0.87)	3.5 (0.14)	6 (0.24)	6 (0.24)	M6, depth 10	1500 (2.02)	8.1 (17.85)	490 (110)	147 (33)
15A316C					M6, depth 10				

- Note**
- 1) The detector uses an incremental encoder 2048 P/R.
 - 2) Type "A" indicates 200 V specification.
 - 3) "15A314B(C)" and "15A316B(C)" have a keyed shaft. The keyway complies with JIS B 1301-1976 (precision). A straight key is supplied.
 - 4) The quoted allowable radial load is the value at a position 35 mm (1.40 in.) from the motor mounting surface.

5) The electromagnetic brake is only to hold the load in position and cannot be used to stop the motor.

- Details of Motor and Encoder Plugs (Common for 100W (0.13 HP) to 750 W (1.01 HP))

Motor Plug



Plug : 350715-1 (AMP)

Pin: No.1 to No.4 350218-6 or 350547-6

Pin: No.5 to No.6 350561-1 or 350690-1

Connected to

Cap: 350781-1

Socket: 350536-6 or 350550-6

Motor Wiring Specifications

1	Phase U	Red
2	Phase V	White
3	Phase W	Blue
4	FG	Green/Yellow
5	Brake terminal	Black
6	Brake terminal	Black

Encoder Plug



Plug: 172169-1 (AMP)

Pin: 170359-1 or 170363-1

Connected to

Cap :172161-1

Socket: 170361-1 or 170365-1

Incremental Encoder Wiring Specifications

1	A channel output	Blue
2	/A channel output	Blue/Black
3	B channel output	Yellow
4	/B channel output	Yellow/Black
5	C channel output	Green
6	/C channel output	Green/Black
7	0V (power supply)	Gray
8	+5V (power supply)	Red
9	FG (Frame Ground)	Orange

上正科技有限公司

購買、維修 此手冊零組件

電話： 037-466333

Email: service@repairtw.com

Line id: @zzzz

www.repairtw.com

SGMP Servomotor
Absolute Encoder with brake (SGMP-15AW□□ Servomotor)

• 1.5kW

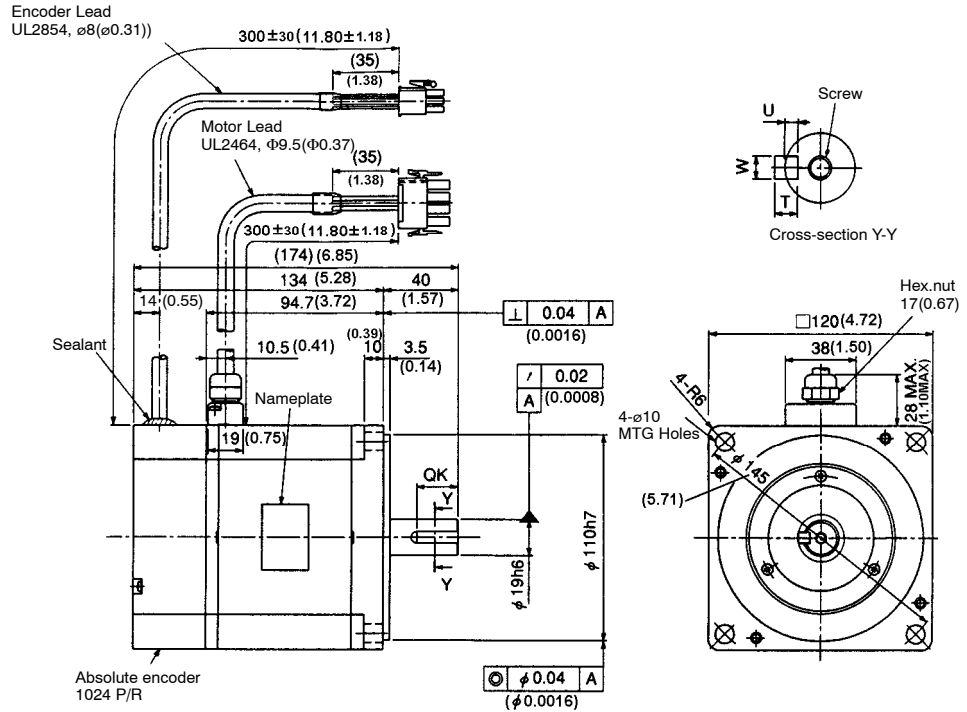

5

上正科技有限公司

購買、維修 此手冊零組件

in mm (inches)

Type SGMP-	QK	U	W	T	Screw Dimensions	Output W (HP)	Approx. mass kg (lb)	Allowable radial load N (lb)	Allowable thrust load N (lb)
15AW12	No key				No Screw	1500 (2.02)	7.1 (15.65)	490 (110)	147 (33)
15AW14	22 (0.87)	3.5 (0.14)	6 (0.24)	6 (0.24)	No Screw				
15AW16	22 (0.87)	3.5 (0.14)	6 (0.24)	6 (0.24)	M6 depth 10				

- Note**
- 1) The detector uses a 12-bit absolute encoder 1024 P/R.
 - 2) Type "A" indicates 200 V specification.
 - 3) "15AW14" and "15AW16" have a keyed shaft. The keyway complies with JIS B 1301-1976 (precision). A straight key is supplied.
 - 4) The quoted allowable radial load is the value at a position 35 mm (1.40 in.) from the motor mounting surface.

- Details of Motor and Encoder Plugs

Motor Plug



Plug : 350779-1 (AMP)
Pin: 350218-6 or 350547-6

Connected to
Cap: 350780-1
Socket: 350536-6 to 350550-6

Motor Wiring Specifications

1	Phase U	Red
2	Phase V	White
3	Phase W	Blue
4	FG	Green/Yellow

Encoder Plug



Plug: 172171-1 (AMP)
Pin: 170359-1 or 170363-1

Connected to
Cap :172163-1
Socket: 170361-1 or 170365-1

Absolute Encoder Wiring Specifications

1	A channel output	Blue
2	/A channel output	White/Blue
3	B channel output	Yellow
4	/B channel output	White/Yellow
5	Z channel output	Green
6	/Z channel output	White/Green
7	0V (power supply)	Black
8	+5V (power supply)	Red
9	FG (Frame Ground)	Green/Yellow
10	S channel output	Purple
11	/S channel output	White/Purple
* (12)	(Capacitor reset)	(Gray)
13	Reset	White/Gray
14	0 V (battery)	White/Orange
15	3.6 V (battery)	Orange

* Terminal to discharge capacitor for product dispatch. Do not use.

上正科技有限公司

購買、維修 此手冊零組件

電話： 037-466333

Email: service@repairtw.com

Line id: @zzzz

www.repairtw.com

SGMP Servomotor
Absolute Encoder with brake (SGMP-15AW□□B,C Servomotor)

• 1.5kW

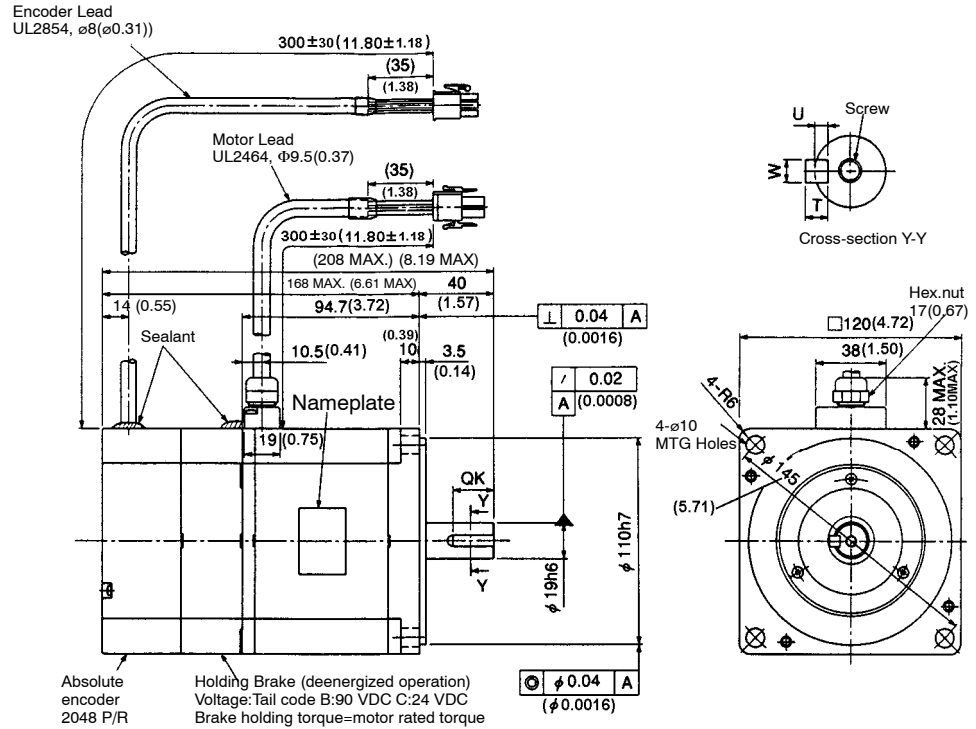

5

上正科技有限公司

購買、維修 此手冊零組件

in mm (inches)

Type SGMP-	QK	U	W	T	Screw Dimensions	Output W (HP)	Approx. mass kg (lb)	Allowable radial load N (lb)	Allowable thrust load N (lb)
15AW12B	No key				No Screw	1500 (2.02)	8.6 (18.95)	490 (110)	147 (33)
15AW12C					No Screw				
15AW14B	22	3.5	6	6	No Screw	1500 (2.02)	8.6 (18.95)	490 (110)	147 (33)
15AW14C	(0.87)	(0.14)	(0.24)	(0.24)	No Screw				
15AW16B	22	3.5	6	6	M6, depth 10	1500 (2.02)	8.6 (18.95)	490 (110)	147 (33)
15AW16C	(0.87)	(0.14)	(0.24)	(0.24)	M6, depth 10				

- Note**
- 1) The detector uses a 12-bit absolute encoder 1024 P/R.
 - 2) Type "A" indicates 200 V specification.
 - 3) "15AW14B(C)" and "15AW16B(C)" have a keyed shaft. The keyway complies with JIS B 1301-1976 (precision). A straight key is supplied.
 - 4) The quoted allowable radial load is the value at a position 35 mm (1.40 in.) from the motor mounting surface.

- 5) The electromagnetic brake is only to hold the load in position and cannot be used to stop the motor.

• Details of Motor and Encoder Plugs

Motor Plug

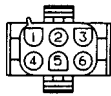

Plug : 350715-1 (AMP)

Pin: No.1 to No.4 350218-6 or 350547-6

Pin: No.5 to No.6 350561-1 or 350690-1

Connected to

Cap: 350781-1

Socket: 350536-6 or 350550-6

Motor Wiring Specifications

1	Phase U	Red
2	Phase V	White
3	Phase W	Blue
4	FG	Green/Yellow
5	Brake terminal	Black
6	Brake terminal	Black

Encoder Plug



Plug: 172171-1 (AMP)

Pin: 170359-1 or 170363-1

Connected to

Cap :172163-1

Socket: 170361-1 or 170365-1

Absolute Encoder Wiring Specifications

1	A channel output	Blue
2	/A channel output	White/Blue
3	B channel output	Yellow
4	/B channel output	White/Yellow
5	Z channel output	Green
6	/Z channel output	White/Green
7	0 V (power supply)	Black
8	+5 V (power supply)	Red
9	FG (Frame Ground)	Green/Yellow
10	S channel output	Purple
11	/S channel output	White/Purple
* (12)	(Capacitor reset)	(Gray)
13	Reset	White/Gray
14	0V(battery)	White/Orange
15	3.6V(battery)	Orange

上正科技有限公司

購買、維修 此手冊與組件

電話： 037-466333

Email: service@repairtw.com

Line id: @zzzz

www.repairtw.com

* Terminal to discharge capacitor for product dispatch. Do not use.

Connectors on Detector and Motor Sides

There are two types for connectors on detector and motor sides: standard connectors and IP67-based connectors. The standard connector is not dripproof.

- Standard Connector (Not dripproof specification)

The specifications of servomotors with holding brake and those of servomotors without holding brake differ.

Standard Connectors for SGM Servomotors without Holding Brake

Motor Type	Connectors on Motor Side			
	Receptacle	L-shaped Plug	Straight Plug	Cable Clamp
SGMS- 10A□A 15A□A 20A□A	MS3102A18-10P	MS3108B18-10S	MS3106B18-10S	MS3057-10A
30A□A 40A□A 50A□A	MS3102A22-22P	MS3108B22-22S	MS3106B22-22S	MS3057-12A
SGMG- 05A□A 09A□A 13A□A	MS3102A18-10P	MS3108B18-10S	MS3106B18-10S	MS3057-10A
20A□A 30A□A 44A□A	MS3102A22-22P	MS3108B22-22S	MS3106B22-22S	MS3057-12A
55A□A 75A□A 1AA□A 1EA□A	MS3102A32-17P	MS3108B32-17S	MS3106B32-17S	MS3057-20A
SGMG- 03A□B 06A□B 09A□B	MS3102A18-10P	MS3108B18-10S	MS3106B18-10S	MS3057-10A
12A□B 20A□B 30A□B	MS3102A22-22P	MS3108B22-22S	MS3106B22-22S	MS3057-12A
44A□B 60A□B	MS3102A32-17P	MS3108B32-17S	MS3106B32-17S	MS3057-20A
SGMD- 22A□A 32A□A 40A□A	MS3102A24-10P	MS3108B24-10S	MS3106B24-10S	MS3057-16A

Connector on motor side already provided

To be prepared by customer

Motor Type	Connectors on Detector Side			
	Receptacle	L-shaped Plug	Straight Plug	Cable Clamp
SGMS- 10A□A 15A□A 20A□A 30A□A 40A□A 50A□A	MS3102A20-29P	MS3108B20-29S	MS3106B20-29S	MS3057-12A
SGMG- 05A□A 09A□A 13A□A 20A□A 30A□A 44A□A 55A□A 75A□A 1AA□A 1EA□A	MS3102A20-29P	MS3108B20-29S	MS3106B20-29S	MS3057-12A
SGMG- 03A□B 06A□B 09A□B 12A□B 20A□B 30A□B 44A□B 60A□B	MS3102A20-29P	MS3108B20-29S	MS3106B20-29S	MS3057-12A
SGMD- 22A□A 32A□A 40A□A	MS3102A20-29P	MS3108B20-29S	MS3106B20-29S	MS3057-12A

Connector on detector side already provided

To be prepared by customer

Email: service@repairtw.com

Line ID: @222z

www.repairtw.com

Connectors for SGM Servomotors with Holding Brake

Motor Type	Connectors on Motor Side			
	Receptacle	L-shaped Plug	Straight Plug	Cable Clamp
SGMS- 10A□A 15A□A 20A□A	MS3102A20-15P	MS3108B20-15S	MS3106B20-15S	MS3057-12A
	MS3102A24-10P	MS3108B24-10S	MS3106B24-10S	MS3057-16A
SGMG- 05A□A 09A□A 13A□A	MS3102A20-15P	MS3108B20-15S	MS3106B20-15S	MS3057-12A
	MS3102A24-10P	MS3108B24-10S	MS3106B24-10S	MS3057-16A
SGMG- 20A□A 30A□A 44A□A	MS3102A32-17P	MS3108B32-17S	MS3106B32-17S	MS3057-20A
	MS3102A10SL-3P	MS3108B10SL-3S	MS3106A10SL-3S	MS3057-4A
SGMG- 55A□A 75A□A 1AA□A 1EA□A	MS3102A20-15P	MS3108B20-15S	MS3106B20-15S	MS3057-12A
	MS3102A24-10P	MS3108B24-10S	MS3106B24-10S	MS3057-16A
SGMG- 03A□B 06A□B 09A□B	MS3102A32-17P	MS3108B32-17S	MS3106B32-17S	MS3057-20A
	MS3102A10SL-3P	MS3108B10SL-3S	MS3106A10SL-3S	MS3057-4A
SGMG- 44A□B 60A□B	MS3102A24-10P	MS3108B24-10S	MS3106B24-10S	MS3057-16A
	MS3102A24-10P	MS3108B24-10S	MS3106B24-10S	MS3057-16A
SGMD- 22A□A 32A□A 40A□A	MS3102A24-10P	MS3108B24-10S	MS3106B24-10S	MS3057-16A

Connector on motor side already provided To be prepared by customer

Line id: @zzzz www.repairtw.com

Email: service@repairtw.com

Note In cells containing two rows, the upper row connector type is for the motor circuit and the connector type lower row is for the brake power supply.

5

Motor Type	Connectors on Detector Side			
	Receptacle	L-shaped Plug	Straight Plug	Cable Clamp
SGMS- 10A□A 15A□A 20A□A 30A□A 40A□A 50A□A	MS3102A20-29P	MS3108B20-29S	MS3106B20-29S	MS3057-12A
SGMG- 05A□A 09A□A 13A□A 20A□A 30A□A 44A□A 55A□A 75A□A 1AA□A 1EA□A	MS3102A20-29P	MS3108B20-29S	MS3106B20-29S	MS3057-12A
SGMG- 03A□B 06A□B 09A□B 12A□B 20A□B 30A□B 44A□B 60A□B	MS3102A20-29P	MS3108B20-29S	MS3106B20-29S	MS3057-12A
SGMD- 22A□A 32A□A 40A□A	MS3102A20-29P	MS3108B20-29S	MS3106B20-29S	MS3057-12A

Connector on detector side already provided

To be prepared by customer

www.repairtw.com

• IP67-based Connectors

IP67-based Connectors for SGM Servomotors without Holding Brake

	Motor Type	Receptacle	Plug	End Bell: Manufactured by Japan Aviation Electronics Industry, Ltd. Back Shell: Manufactured by Daiichi Denshi Kogyo K.K.		Cable Clamp	Manufacturer																			
				Angle (L-Shaped)	Straight																					
M o t o r	SGMS- 10A□A 15A□A 20A□A 30A□A 40A□A 50A□A	CE05-2A18- 10PD (MS3102A18- 10P)	MS3106A18- 10S(D190)	CE-18BA-S	CE02-18BS-S	CE3057-10A-※	Daiichi Denshi Kogyo K.K																			
								JL04HV-2E22- 22PE-B (MS3102A22- 22P)	JL04V-6A22- 22SE	JL04-22EBL	JL04-22EB	JL04-2022CK (※※)	Japan Aviation Electronics Industry, Ltd.													
														CE05-2A18- 10PD (MS3102A18- 10P)	MS3106A18- 10S(D190)	CE-18BA-S	CE02-18BS-S	CE3057-10A-※	Daiichi Denshi Kogyo K.K							
																				JL04HV-2E22- 22PE-B (MS3102A22- 22P)	JL04V-6A22- 22SE	JL04-22EBL	JL04-22EB	JL04-2022CK (※※)	Japan Aviation Electronics Industry, Ltd.	
																										JL04V-2E32- 17PE-B (MS3102A32- 17P)
	SGMG- 05A□A 09A□A 13A□A 20A□A 30A□A 44A□A 55A□A 75A□A 1AA□A 1EA□A	CE05-2A18- 10PD (MS3102A18- 10P)	MS3106A18- 10S(D190)	CE-18BA-S	CE02-18BS-S	CE3057-10A-※	Daiichi Denshi Kogyo K.K																			
								JL04HV-2E22- 22PE-B (MS3102A22- 22P)	JL04V-6A22- 22SE	JL04-22EBL	JL04-22EB	JL04-2022CK (※※)	Japan Aviation Electronics Industry, Ltd.													
														JL04V-2E32- 17PE-B (MS3102A32- 17P)	JL04V-6A32- 17SE	*1	*1	*1	Japan Aviation Electronics Industry, Ltd.							
																				SGMG- 03A□B 06A□B 09A□B 12A□B 20A□B 30A□B 44A□B 60A□B	CE05-2A18- 10PD (MS3102A18- 10P)	MS3106A18- 10S(D190)	CE-18BA-S	CE02-18BS-S	CE3057-10A-※	
																										JL04HV-2E22- 22PE-B (MS3102A22- 22P)
JL04V-2E32- 17PE-B (MS3102A24- 10P)	JL04V-6A32- 17SE	*1	*1	*1	Japan Aviation Electronics Industry, Ltd.																					
						SGMD- 22A□A 32A□A 40A□A	JL04V-2E24- 10PE-B (MS3102A32- 17P)	JL04-6A24- 10SE	JL04-24EBL	JL04-24EB	JL04-2428CK (※※)	Japan Aviation Electronics Industry, Ltd.														
													Detector	97F3102E20- 29P (MS3102A20- 29P)	MS3106A20- 29S(D190)	CE-20BA-S	CE02-20BS-S	CE3057-12A-※	Daiichi Denshi Kogyo K.K							

Connector on motor side already provided

To be selected if flexible conduit is used

Not required if flexible conduit is used

To be prepared by customer

*1 The SGMG-55A□A, -75A□A, -1AA□A, -1EA□A, -44A□B, and -60A□B motors do not contain an End Bell. For these motors, use the following flexible conduit instead.

Connector		Conduit Type	Manufacturer
Angle (L-Shaped)	Straight		
RCC-3**RL-MS32F	RCC-1**RL-MS32F	VF-** (SR-**)	Nippon Flex Co., Ltd.

Select an appropriate connector and conduit type (mark **) according to the lead wire diameter. For details, refer to page 430.

- Note**
- 1) The connectors for a detector are the same regardless of the motor type being used.
 - 2) To ensure compliance with IP67, always use the plug, End Bell, Back Shell and cable clamp specified above.
 - 3) Select an appropriate cable clamp type (mark**) according to the lead wire diameter. For details, refer to page 430.
 - 4) () in the receptacle column shows the standard (non-dripproof) type. However, both are actually the same receptacles.

上正科技有限公司

購買、維修 此手冊零組件

電話： 037-466333

Email: service@repairtw.com

Line id: @zzzz

www.repairtw.com

IP67-based Connectors for SGM Servomotors with Holding Brake

	Motor Type	Receptacle	Plug	End Bell: Manufactured by Japan Aviation Electronics Industry, Ltd. Back Shell: Manufactured by Daiichi Denshi Kogyo K.K.		Cable Clamp	Manufacturer																		
				Angle (L-Shaped)	Straight																				
M o t o r	SGMS- 10A□A 15A□A 20A□A 30A□A 40A□A 50A□A	JL04V-2E20- 15PE-B (MS3102A20- 15P)	JL04V-6A20- 15SE	JL04-20EBL	JL04-20EB	JL04-2022CK (*※)	Japan Aviation Electronics Industry, Ltd.																		
								SGMG- 05A□A 09A□A 13A□A 20A□A 30A□A 44A□A 55A□A 75A□A 1AA□A 1EA□A	JL04-2E24- 10PE-B (MS3102A24- 10P)	JL04V-6A24- 10SE	JL04-24EBL	JL04-24EB	JL04-2428CK (*※)	Japan Aviation Electronics Industry, Ltd.											
															JL04V-2E32- 17PE-B (MS3102A32- 17P)	JL04V-6A32- 17SE MS3106A10 SL-3S(D190)	*1 CE-10SLBA-S	*1 CE05-10SLBS- S	*1 CE3057-4A-1	Japan Aviation Electronics Industry, Ltd. Daiichi Denshi Kogyo K.K					
																					CE05-2A10SL- 3PC (MS3102A10SL -3P)	*1 CE-10SLBA-S	*1 CE05-10SLBS- S	*1 CE3057-4A-1	Japan Aviation Electronics Industry, Ltd. Daiichi Denshi Kogyo K.K
	JL04-2E24- 10PE-B (MS3102A24- 10P)	JL04V-6A24- 10SE	JL04-24EBL	JL04-24EB	JL04-2428CK (*※)	Japan Aviation Electronics Industry, Ltd.																			
							JL04V-2E32- 17PE-B (MS3102A32- 17P)	JL04V-6A32- 17SE MS3106A10 SL-3S(D190)	*1 CE-10SLBA-S	*1 CE05-10SLBS- S	*1 CE3057-4A-1	Japan Aviation Electronics Industry, Ltd. Daiichi Denshi Kogyo K.K													
	CE05-2A10SL- 3PC (MS3102A10SL -3P)	*1 CE-10SLBA-S	*1 CE05-10SLBS- S	*1 CE3057-4A-1	Japan Aviation Electronics Industry, Ltd. Daiichi Denshi Kogyo K.K																				
						SGMD- 22A□A 32A□A 40A□A	JL04-2E24- 10PE-B (MS3102A20- 15P)	JL04V-6A24- 10SE	JL04-24EBL	JL04-24EB	JL04-2428CK (*※)	Japan Aviation Electronics Industry, Ltd.													
	Detector	97F3102E20- 29P (MS3102A20- 29P)	MS3106A20- 29S(D190)	CE-20BA-S	CE02-20BS-S								CE3057-12A- ※	Daiichi Denshi Kogyo K.K											

Connector on motor side already provided

To be selected if flexible conduit is used

Not required if flexible conduit is used

To be prepared by customer

*1 The SGMG-55A□A, -75A□A, -1AA□A, 1EA□A, -44A□B, and -60A□B motors do not contain an End Bell. For these motors, use the following flexible conduit instead.

Connector		Conduit Type	Manufacturer
Angle (L-Shaped)	Straight		
RCC-3**RL-MS32F	RCC-1**RL-MS32F	VF-** (SR-**)	Nippon Flex Co., Ltd.

Select an appropriate connector and conduit type (mark **) according to the lead wire diameter. For details, refer to page 430.

- Note**
- 1) The connectors for a detector are the same regardless of the motor type being used.
 - 2) To ensure compliance with IP67, always use the plug, End Bell, Back Shell and cable clamp specified above.
 - 3) Select an appropriate cable clamp type (mark **) according to the lead wire diameter. For details, refer to page 430.
 - 4) () in the receptacle column shows the standard (non-dripproof) type. However, both are actually the same receptacles.

上正科技有限公司

購買、維修 此手冊零組件

電話： 037-466333

Email: service@repairtw.com

Line id: @zzzz

www.repairtw.com

5.4.2 SERVOPACK Dimensional Drawings

The dimension drawings of the SGDB SERVOPACK are broadly grouped into the following categories according to the capacity and location of heat sink.

SERVOPACK with Heat Sink Mounted Inside Panel

- 0.3 to 1.5 kW (0.4 to 2.0 HP) (Type: SGDB-03AD□ to 15AD□)
- 2.0 to 3.0 kW (2.7 to 4.0 HP) (Type: SGDB-20AD□ to 30AD□)
- 4.4 to 5.0 kW (5.9 to 6.7 HP) (Type: SGDB-44AD□ to 50AD□)
- 6.0 to 7.5 kW (8.0 to 10 HP) (Type: SGDB-60AD□ to 75AD□)
- 11 to 15kW (15 to 20HP) (Type: SGDB-1AAD□ to 1EAD□)

SERVOPACK with Heat Sink Mounted Outside Panel

- 0.3 to 1.5 kW (0.4 to 2.0 HP) (Type: SGDB-03AD□-P to 15AD□-P)
- 2.0 to 3.0 kW (2.7 to 4.0 HP) (Type: SGDB-20AD□-P to 30AD□-P)
- 4.4 to 5.0 kW (5.9 to 6.7 HP) (Type: SGDB-44AD□-P to 50AD□-P)
- 6.0 to 7.5 kW (8.0 to 10 HP) (Type: SGDB-60AD□-P to 75AD□-P)
- 11 to 15kW (15 to 20HP) (Type: SGDB-1AAD□-P to 1EAD□-P)

上正科技有限公司
 購買、維修 此手冊零組件
 電話： 037-466333
 Email: service@repairtw.com
 Line id: @zz77
 www.repairtw.com

■ SERVOPACK with Heat Sink Mounted Inside Panel

SGDB-03AD□ to 15AD□ (0.3 to 1.5 kW; 0.4 to 2.0 HP)

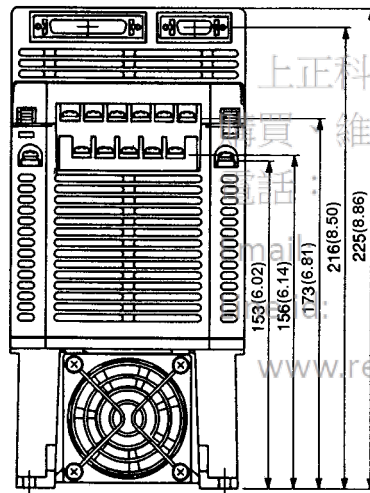
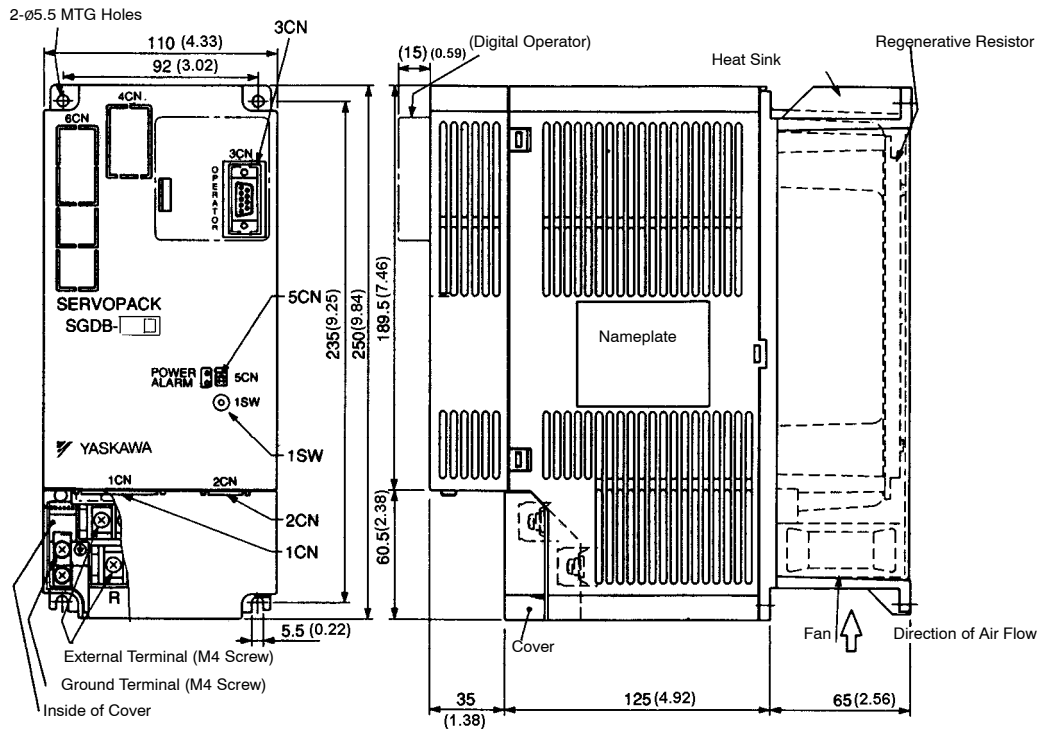

Dimensions in mm (inches)
Approx. Mass: 4 kg (8.82 lb)

- SGDB-03AD□ (0.3 kW) to 1AAD□ (11 kW) -Type Common

Connector No.	Connector type on SERVOPACK side	Note
1CN	10250-52A2JL	manufactured by 3M
2CN	10220-52A2JL	
3CN	17JE-13090-37(D2B)	manufactured by Daiichi Denshi Kogyo K.K.
4CN	DF11-4DP-2DSA	manufactured by Hirose Denki

USING THE DIGITAL OPERATOR

5.4.2 SERVOPACK Dimensional Drawings cont.

SGDB-20AD to 30AD (2.0 to 3.0 kW; 2.7 to 4.0 HP)

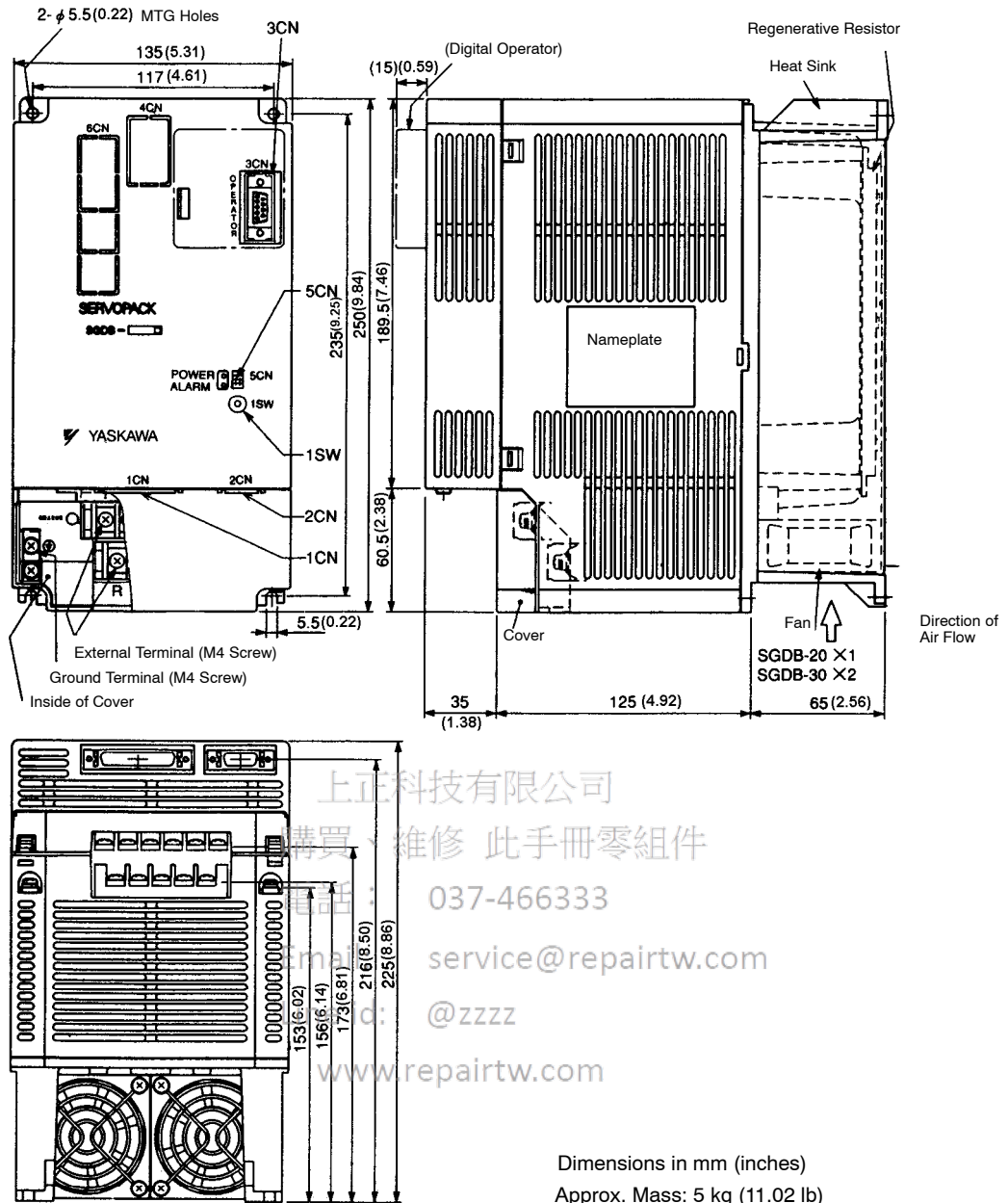

SGDB-44AD□ to 50AD□ (4.4 to 5.0 kW; 5.9 to 6.7 HP)

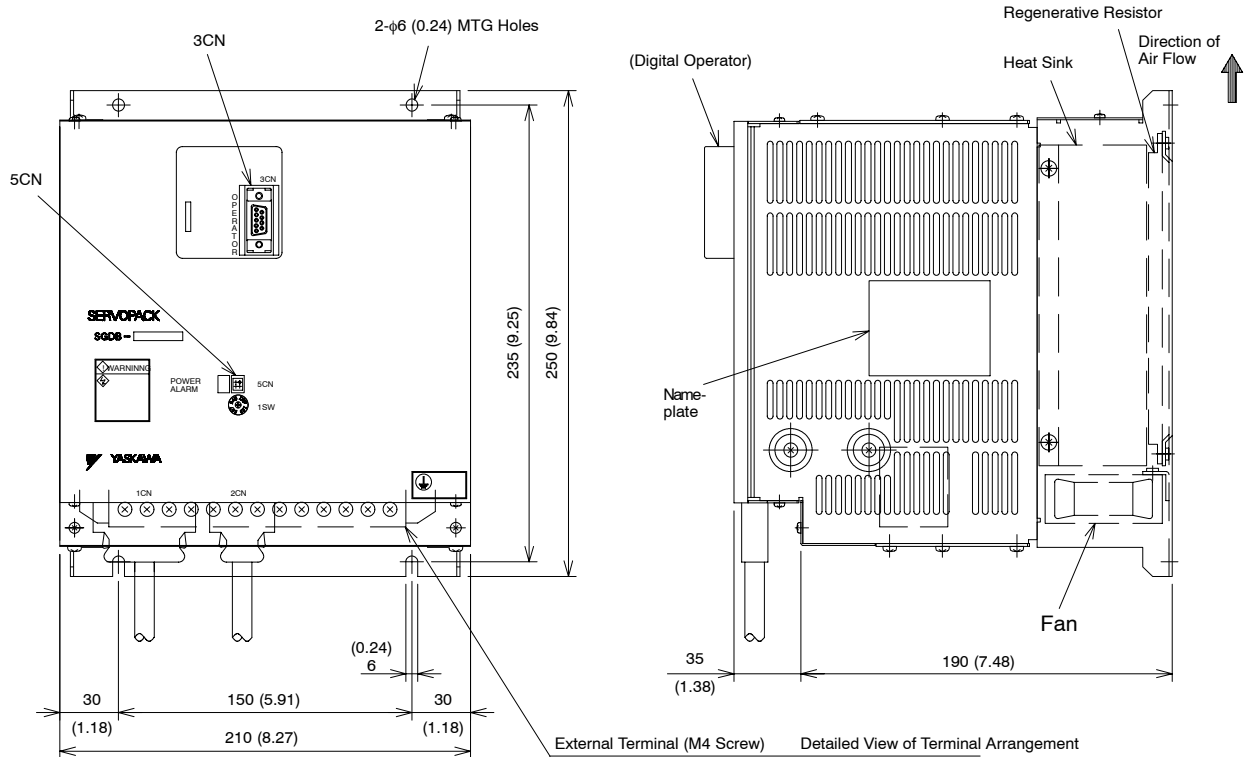

External Terminal (M4 Screw) Detailed View of Terminal Arrangement

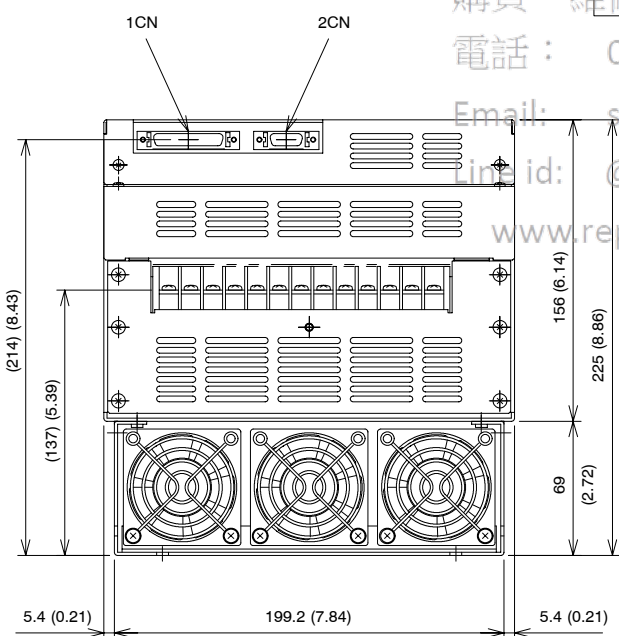
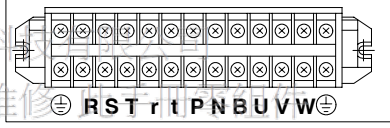

Dimensions in mm (inches)
 Approx. Mass: 8 kg (17.63 lb)

上正利
 購買、維修 RST r t P N B U V W
 電話： 037-466333
 Email: service@repairtw.com
 Line id: @zzzz
 www.repairtw.com

USING THE DIGITAL OPERATOR

5.4.2 **SERVOPACK** Dimensional Drawings cont.

SGDB-60AD □ to 75AD □ (6.0 to 7.5 kW; 8.0 to 10 HP)

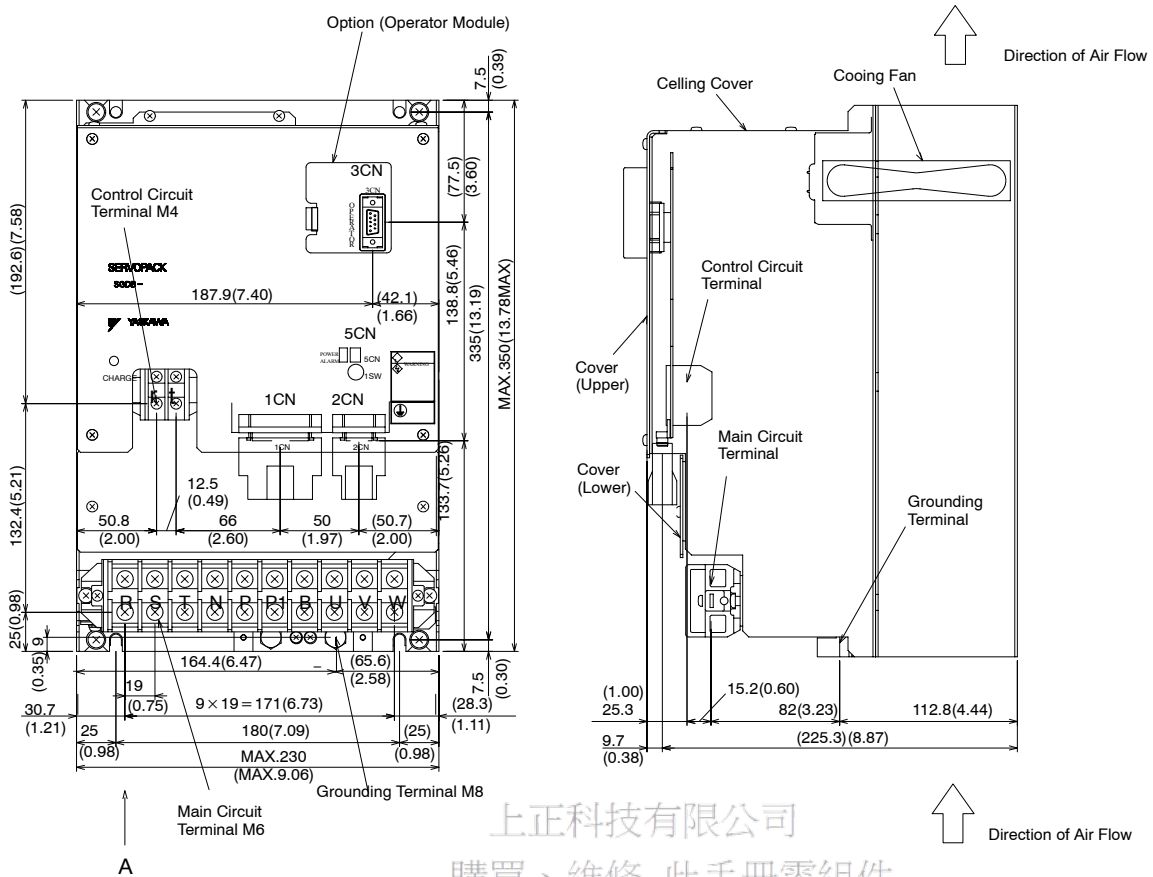

5

上正科技有限公司

購買、維修 此手冊零組件

電話： 037-466333

Email: service@repairtw.com

Line id: @zzzz

www.repairtw.com

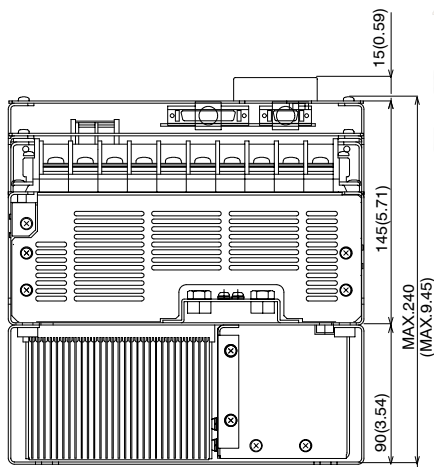

Viewed from A

Dimensions in mm (inches)

Approx. Mass: 15 kg (33.06 lb)

SGDB-1AAD□ to 1EAD□ (11 to 15kW; 15 to 20HP)

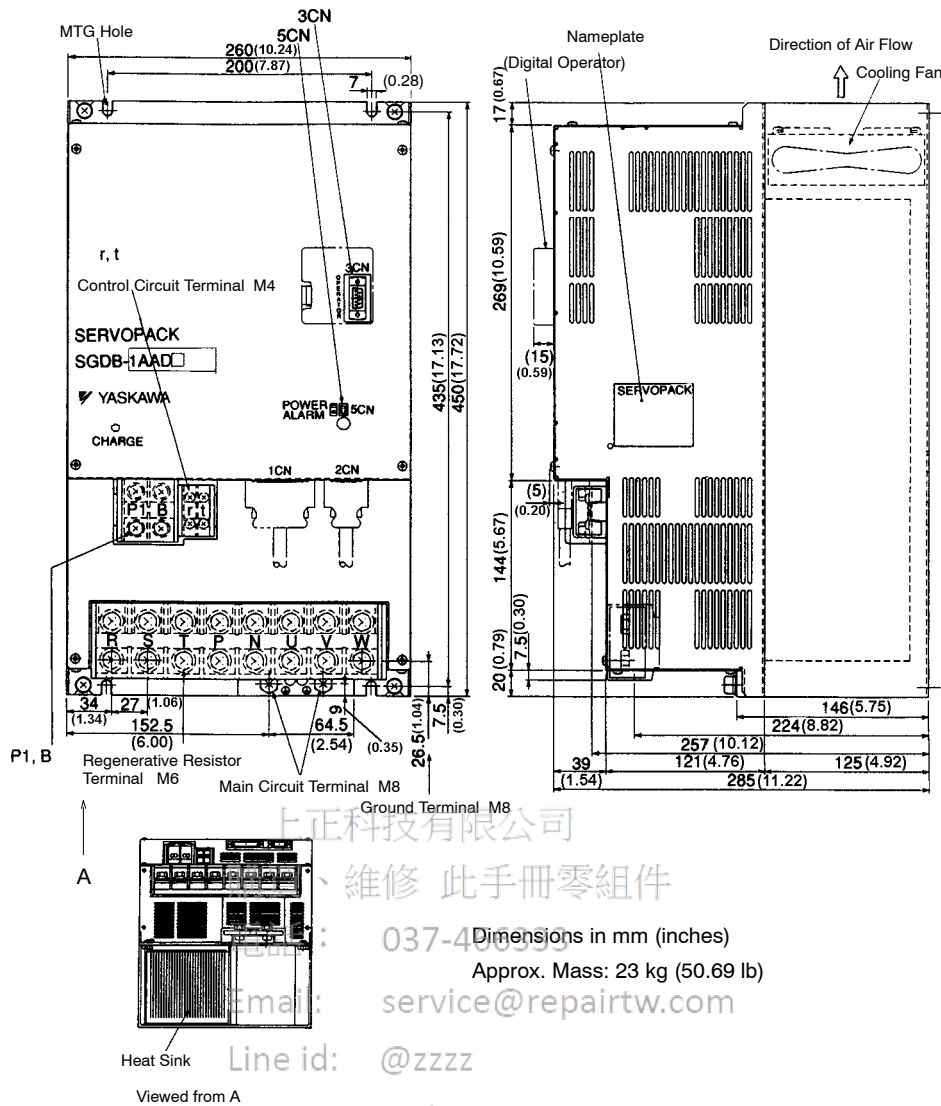

5

- SGDB-03 to 1EAD□P-Type Common

Connector No.	Connector type on SERVOPACK side	Note
1CN	10250-52A2JL	manufactured by 3M
2CN	10220-52A2JL	
3CN	17JE-13090-37(D2B)	manufactured by Daiichi Denshi Kogyo K.K.
5CN	DF11-4DP-2DSA	manufactured by Hirose Denki

■ SERVOPACK with Heat Sink Mounted Outside Panel (option)

A duct ventilation type is available for SERVOPACKs in which a heat sink is mounted outside the control panel.

This installation method has the following advantages:

- Discharges generated heat out of the control panel to prevent a temperature rise inside the panel
- Makes the control panel compact and provides high reliability

上正科技有限公司

購買、維修 此手冊零組件

電話： 037-466333

Email: service@repairtw.com

Line id: @zzzz

www.repairtw.com

SGDB-03AD□ to 15AD□-P

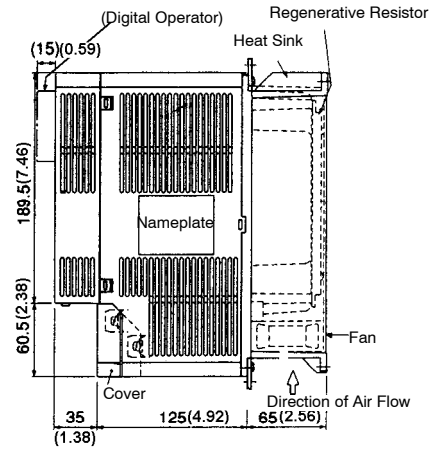
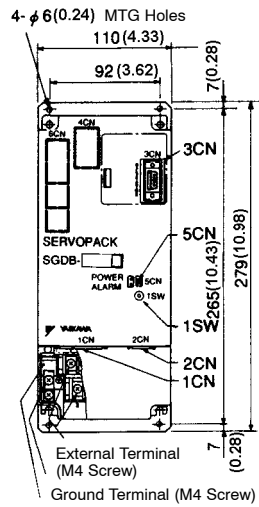

Inside of Cover

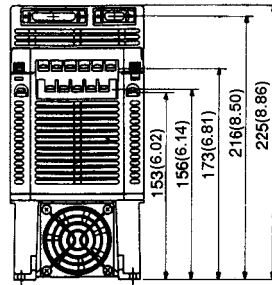

Dimensions in mm (inches)

Approx. Mass: 4 kg (8.82 lb)

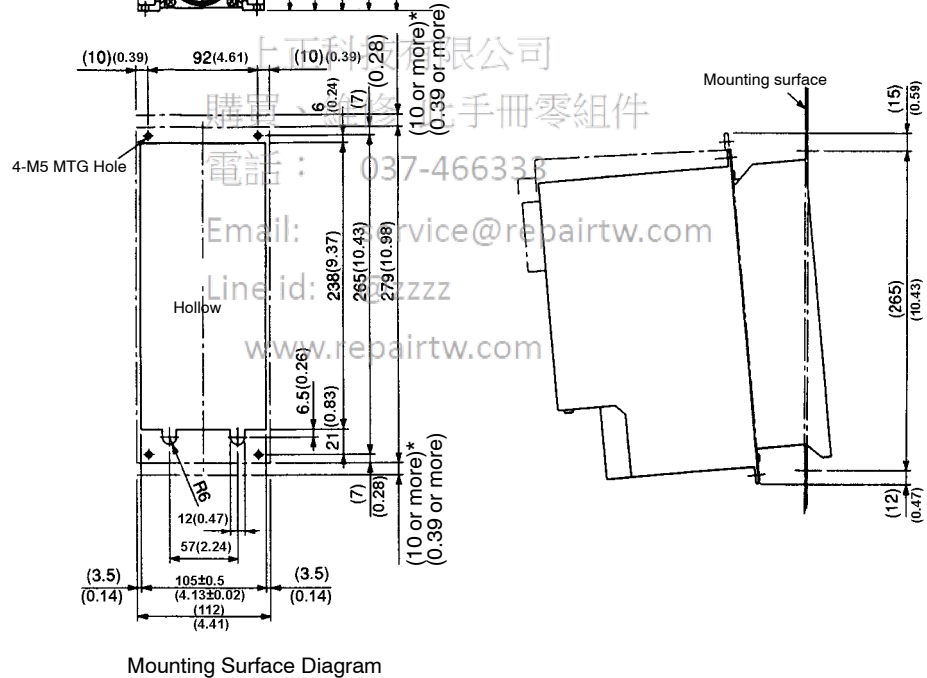

Mounting Surface Diagram

* The SERVOPACK must be inclined as shown in the above figure. Provide at least 10mm (0.39 in.) space at the top and bottom of the SERVOPACK.

USING THE DIGITAL OPERATOR

5.4.2 SERVOPACK Dimensional Drawings cont.

SGDB-20AD□, 30AD□-P

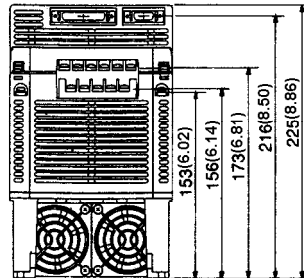
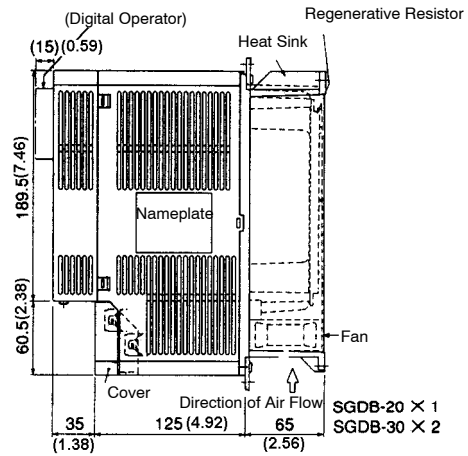
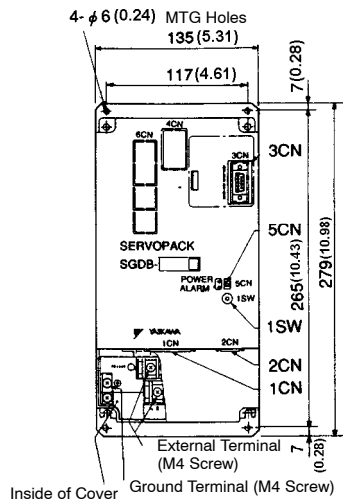

Dimensions in mm (inches)

Approx. Mass: 5 kg (11.02 lb)

5

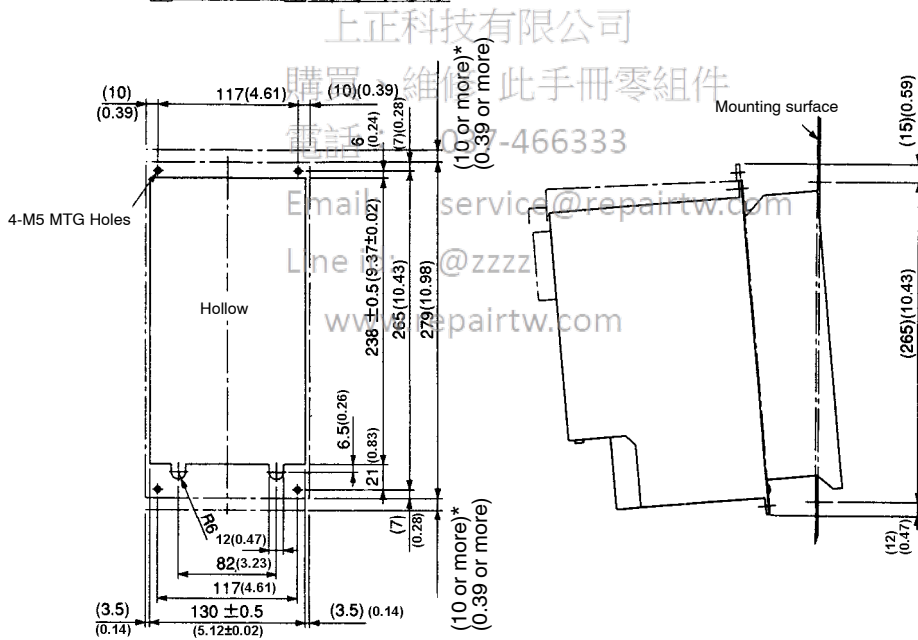

Mounting Surface Diagram

* The SERVOPACK must be inclined as shown in the above figure. Provide at least 10mm (0.39 in.) space at the top and bottom of the SERVOPACK.

SGDB-44AD□, 50AD□-P

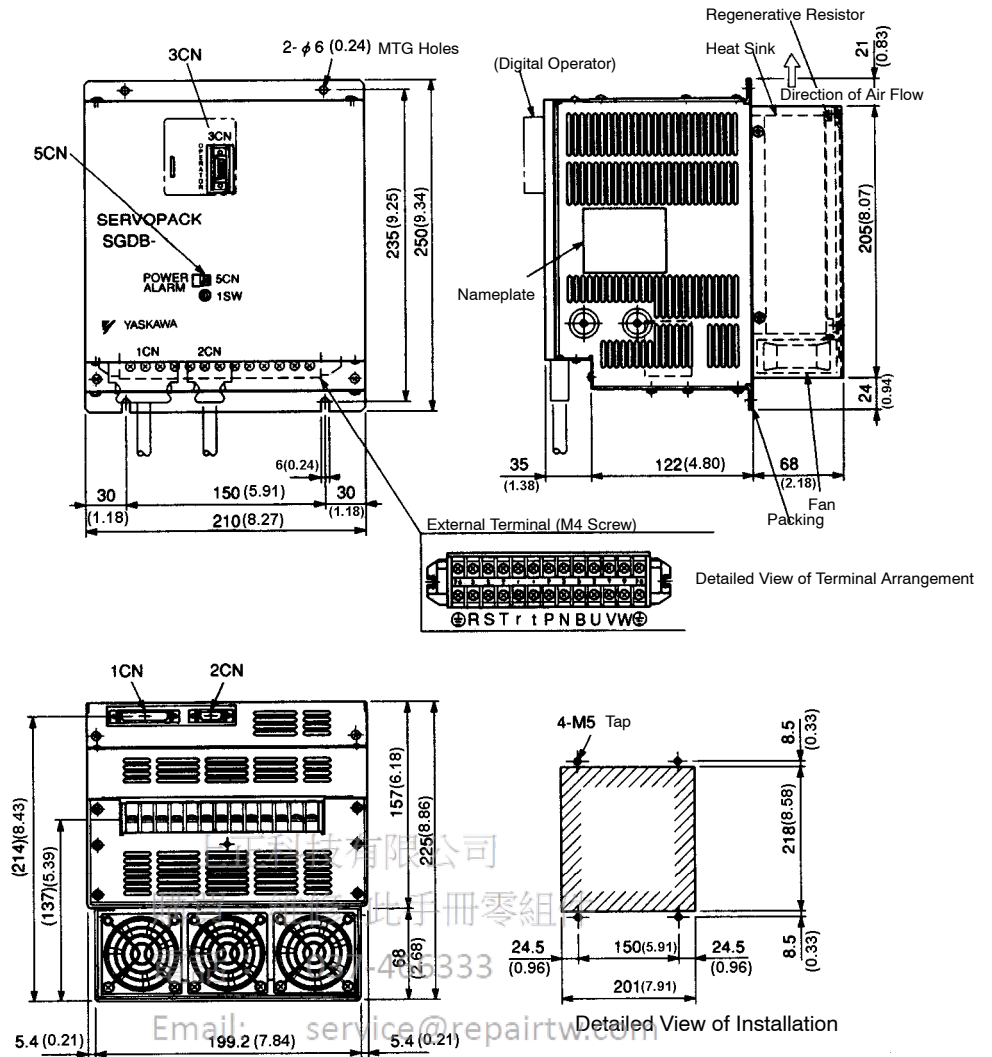

5

Email: service@repairtw.com
 Line id: @zzzz
www.repairtw.com

Dimensions in mm (inches)
 Approx. Mass: 8 kg (17.63 lb)

SGDB-60AD, 75AD-P

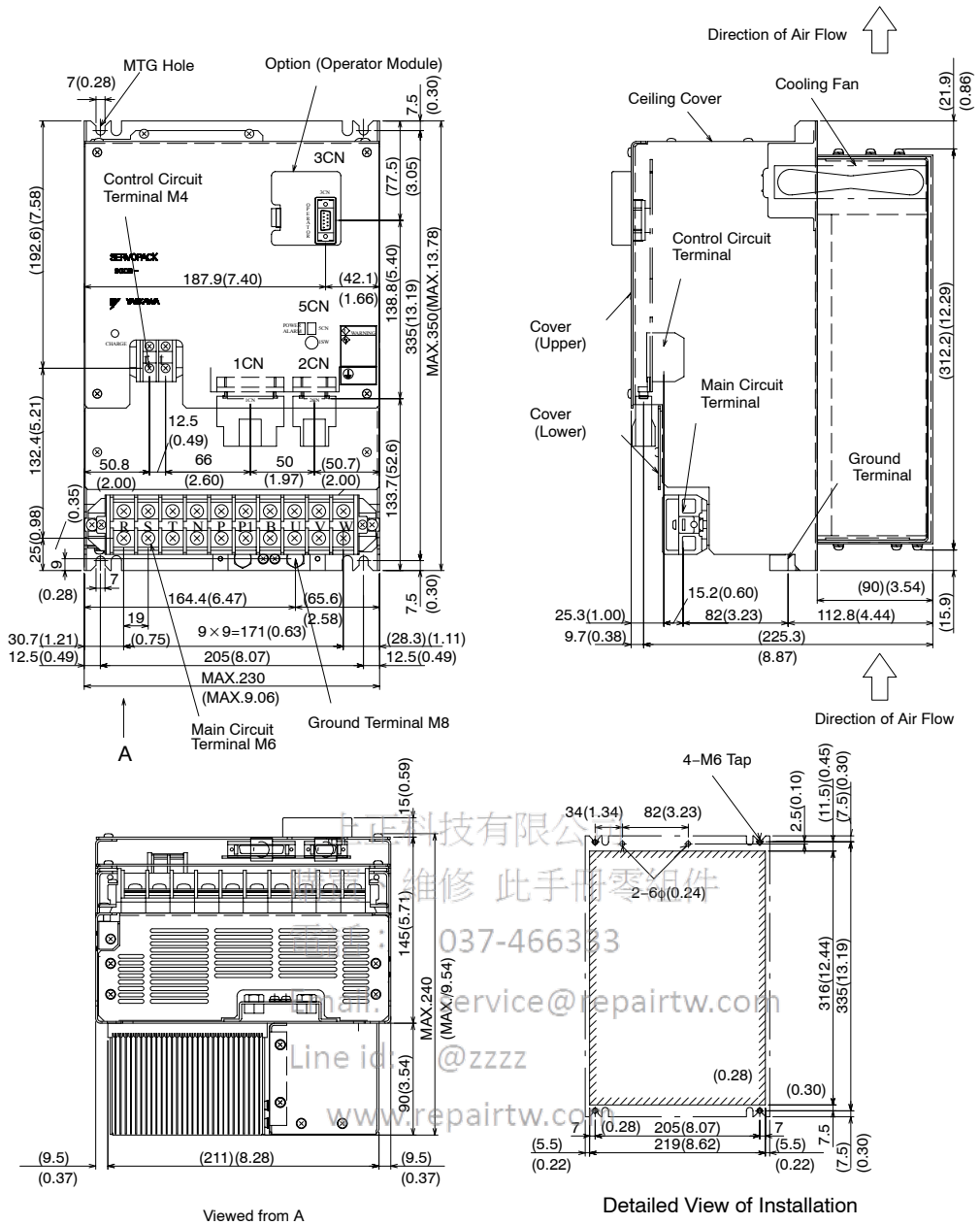

Dimensions in mm (inches)
 Approx. Mass: 15.5kg (34.16 lb)

SGDB-1AAD□-P, -1EAD□-P

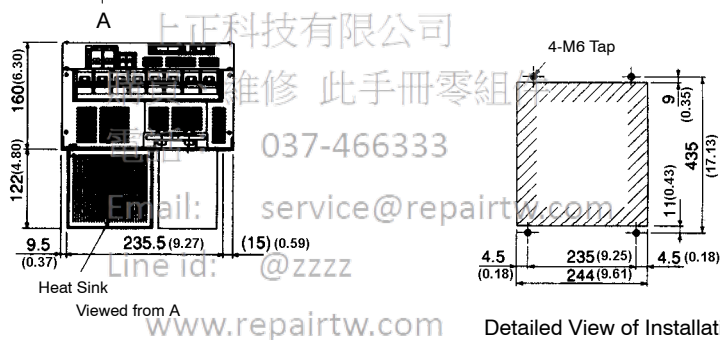
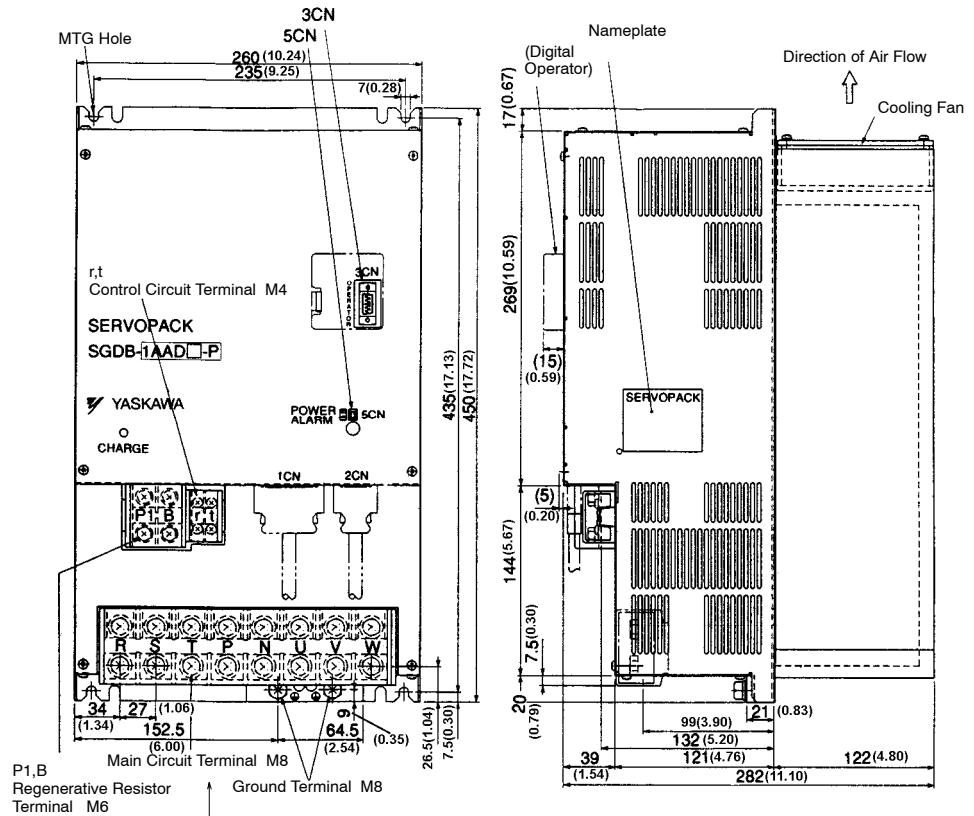

Dimensions in mm (inches)
 Approx. Mass: 22 kg (48.49 lb)

上正科技有限公司
 維修 此手冊零組件
 037-466333
 Email: service@repairtw.com
 Line id: @zzzz
 www.repairtw.com

5.4.3 Digital Operator Dimensional Drawings

The following two types of Digital Operator are available.

- JUSP-OP02A-1 (Hand-held Type)
- JUSP-OP03A (Mount Type)

JUSP-OP02A-1

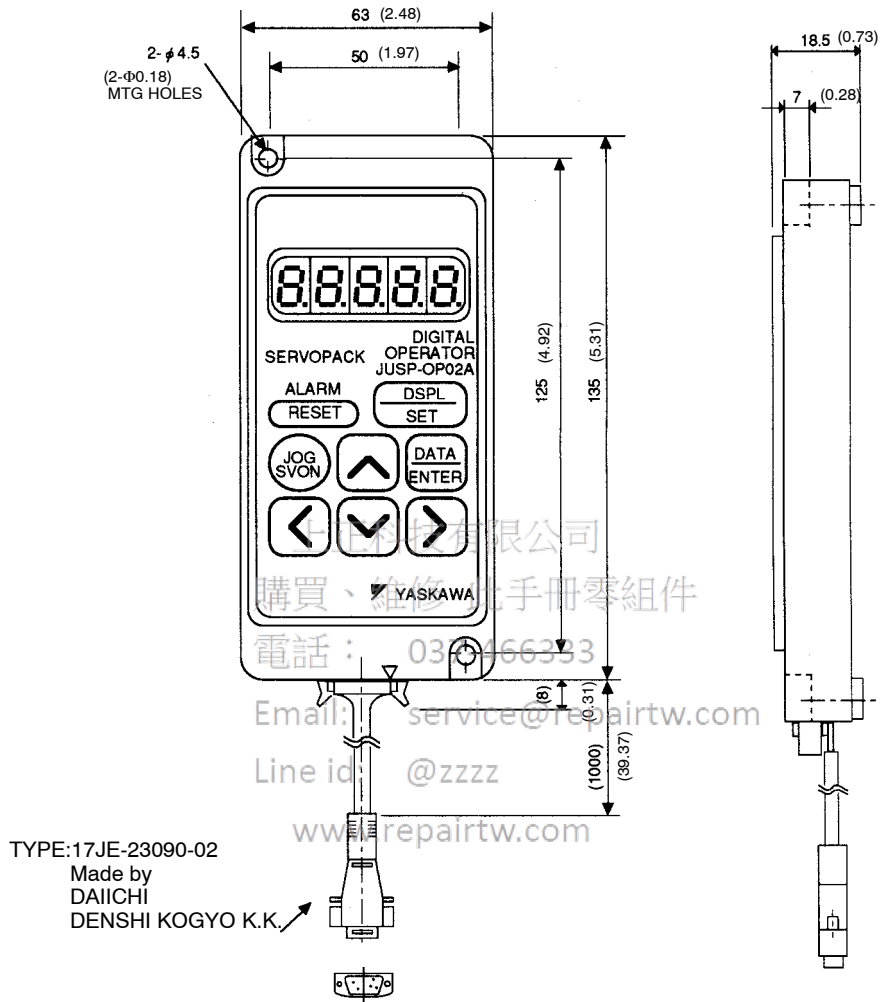

Dimensions in mm (inches)
Approx. Mass: 0.18 kg (0.40 lb)

JUSP-OP03A

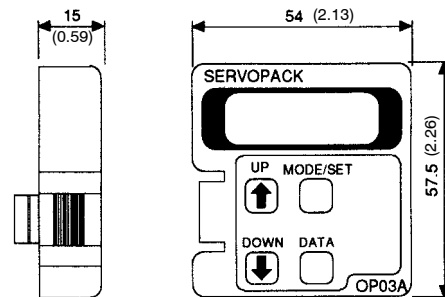

Dimensions in mm (inches)
Approx. Mass: 0.02 kg (0.041lb)

上正科技有限公司
購買、維修 此手冊零組件
電話： 037-466333
Email: service@repairtw.com
Line id: @zzzz
www.repairtw.com

5.5 Selecting Peripheral Devices

This section shows how to select peripheral devices using flowcharts. Order lists for servomotors, SERVOPACKs, digital operators, and peripheral devices are also included.

5.5.1 Selecting Peripheral Devices

Select the peripheral devices using the flowcharts on the subsequent pages.

The items below are not included in the flowcharts. Refer to *Section 5.6 Specifications and Dimensional Drawings of Peripheral Devices*.

- Variable resistors for speed setting
- Encoder signal converter units
- Cables for connecting PC and SERVOPACK

上正科技有限公司

購買、維修 此手冊零組件

電話： 037-466333

Email: service@repairtw.com

Line id: @zzzz

www.repairtw.com

<Flowchart for peripheral device selection>

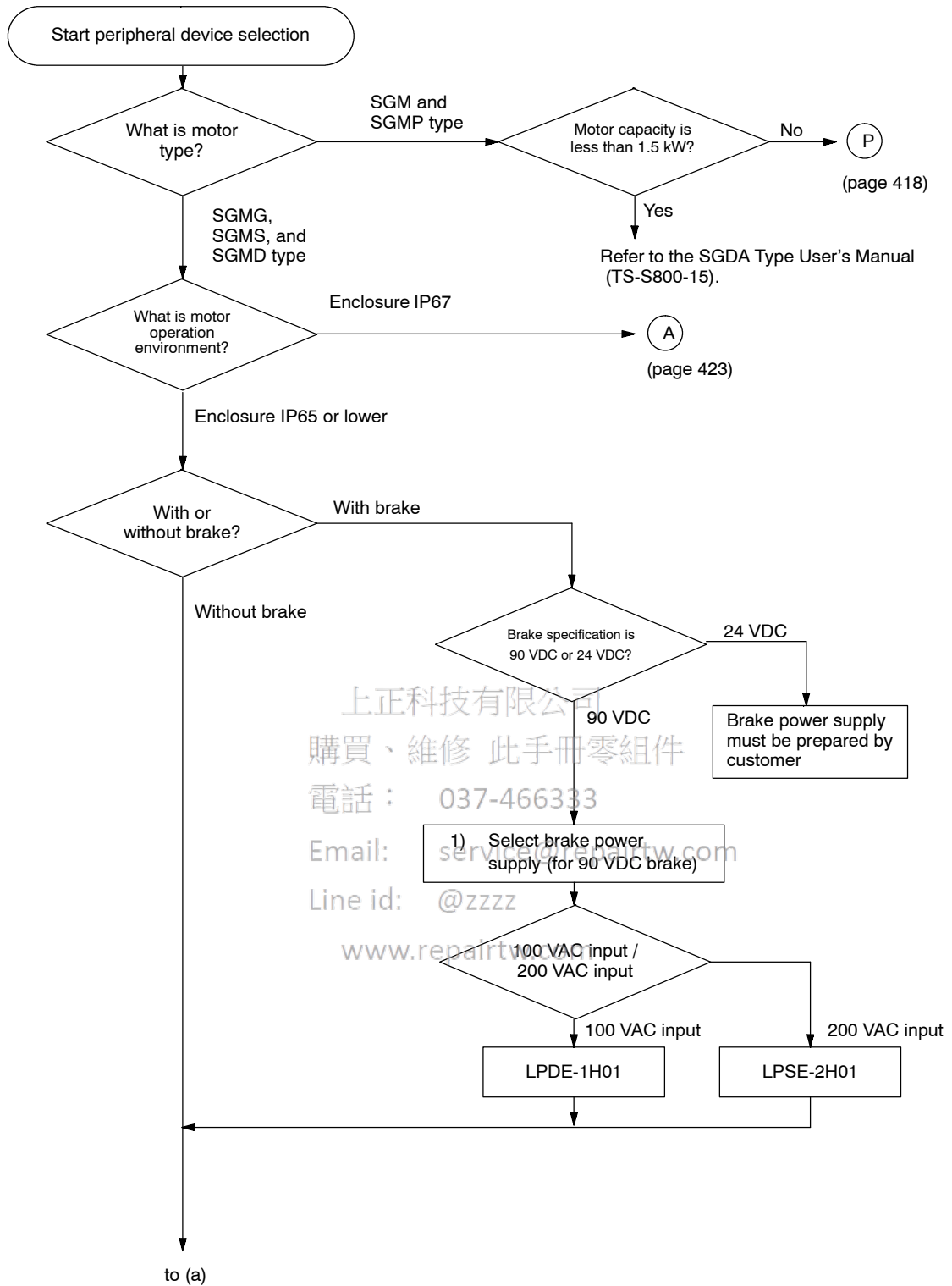

上正科技有限公司
 購買、維修 此手冊零組件
 電話： 037-466333
 Email: service@repairtw.com
 Line id: @zzzz
 www.repairtw.com

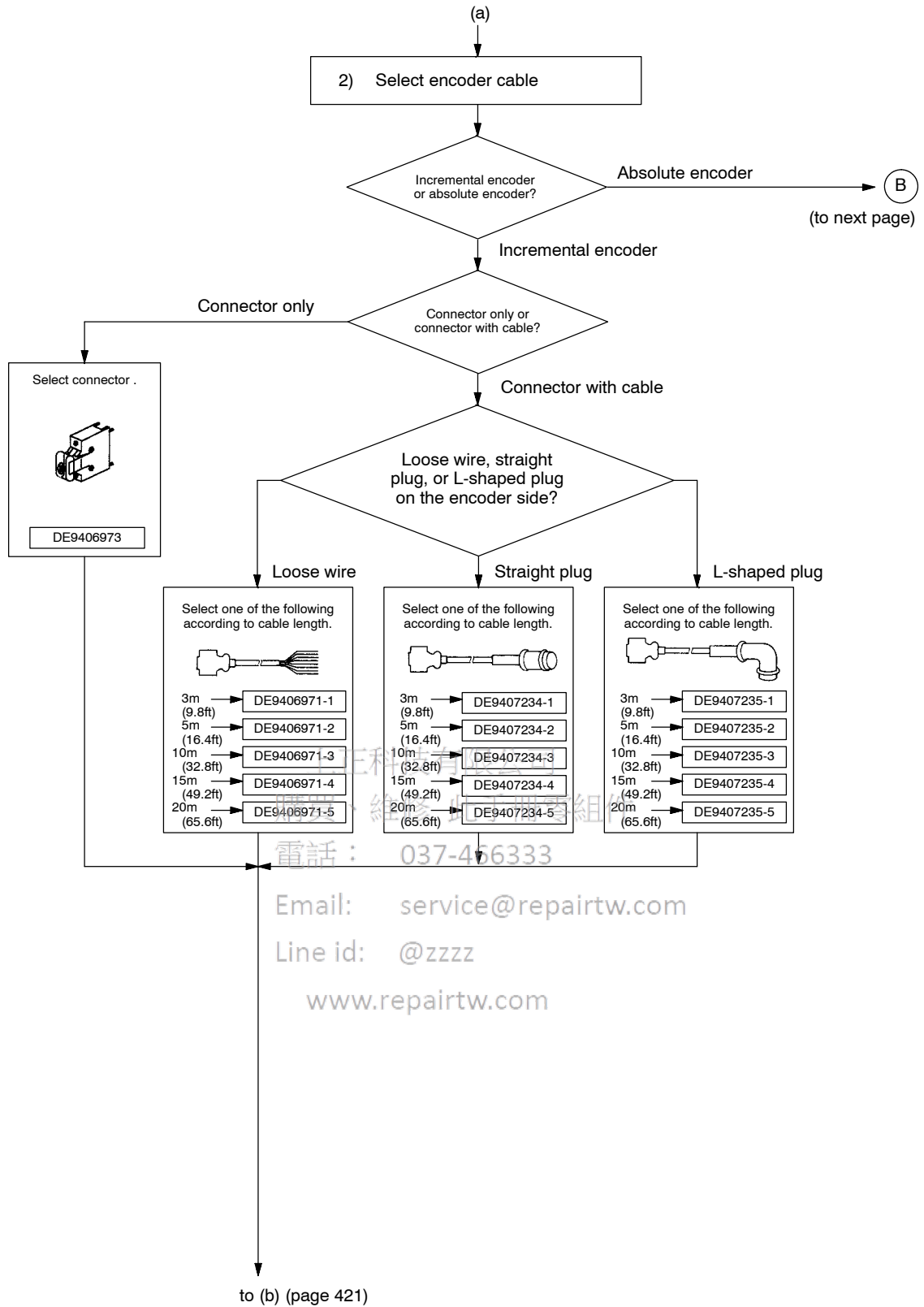

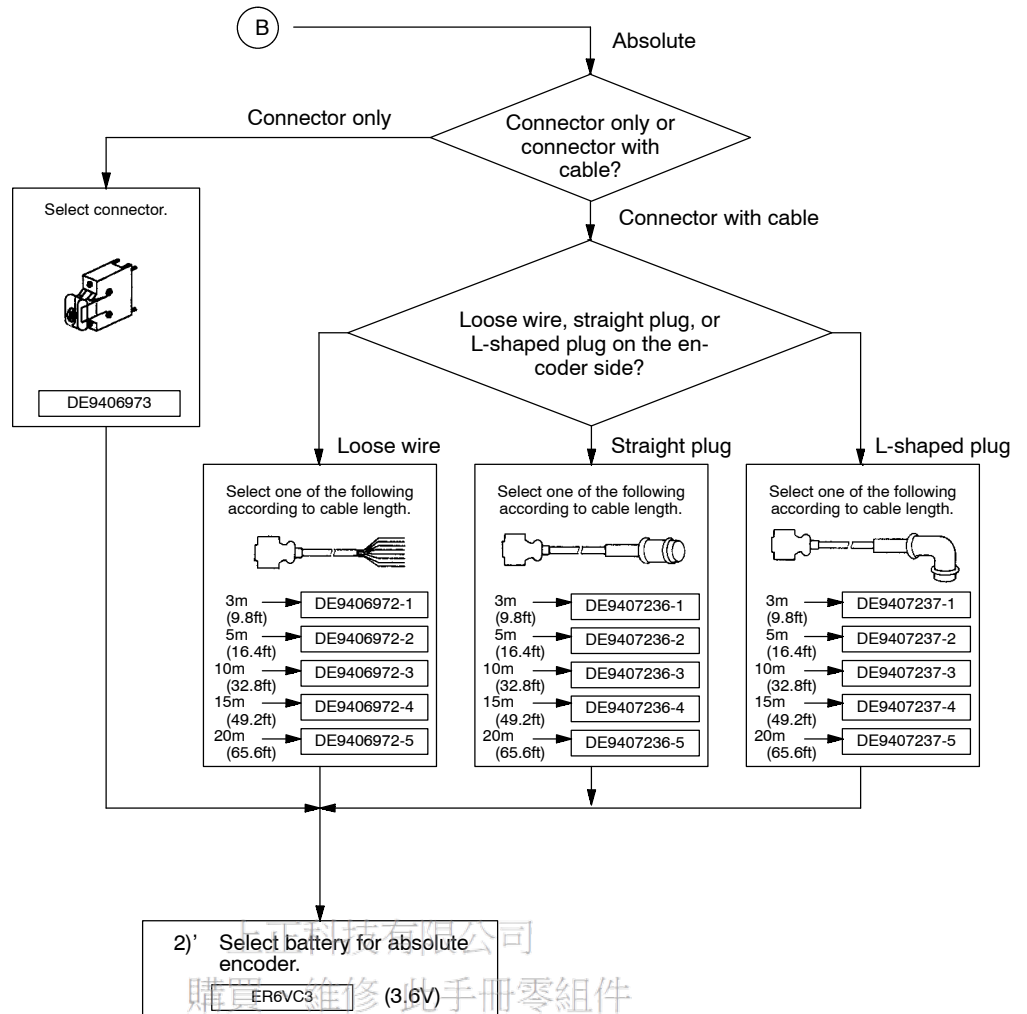

上海利得技术有限公司
 購買維修此手冊零組件
 電話： 037-466333
 Email: to (b) (page 421)@repairtw.com
 Line id: @zzzz
 www.repairtw.com

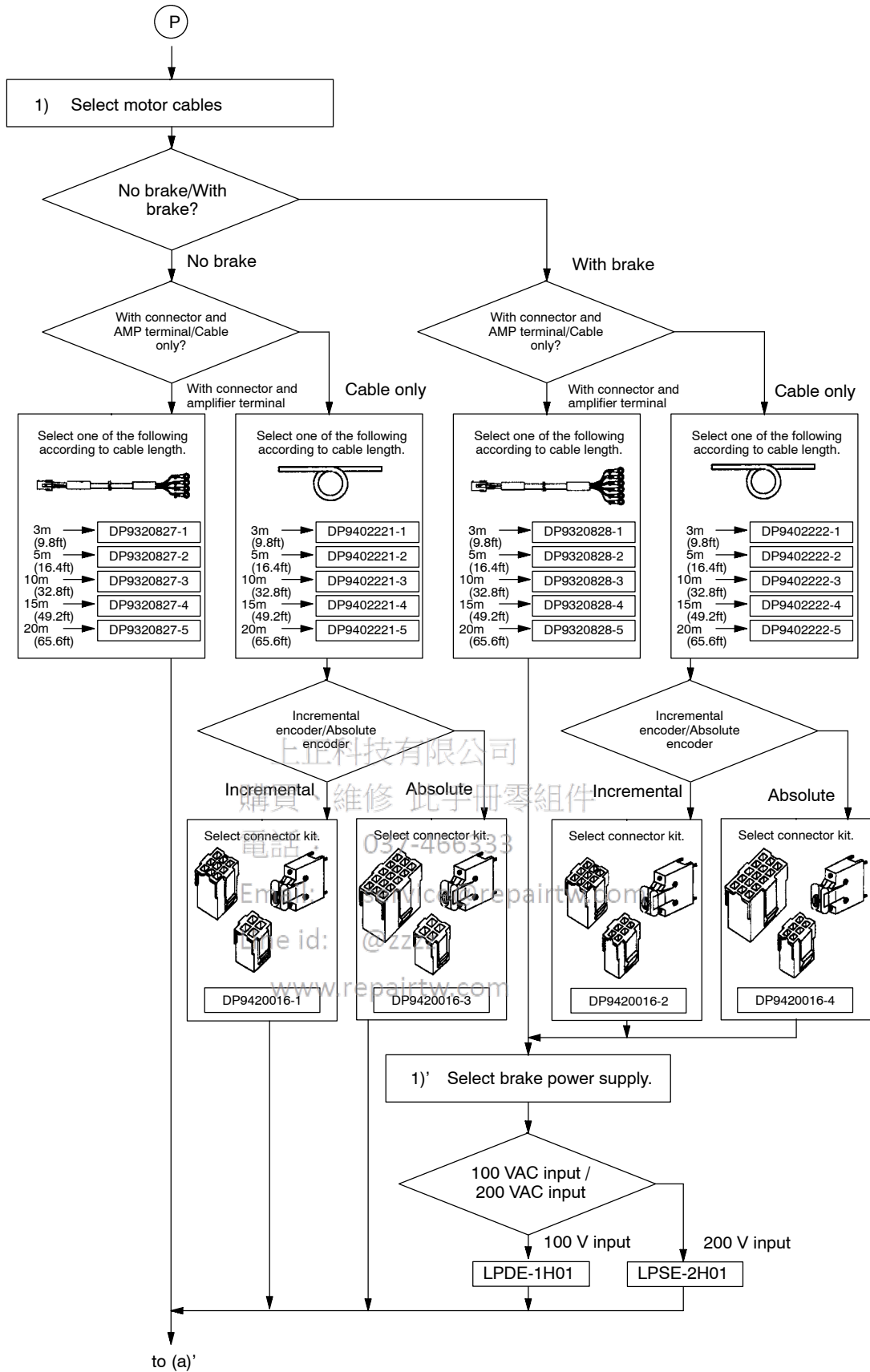

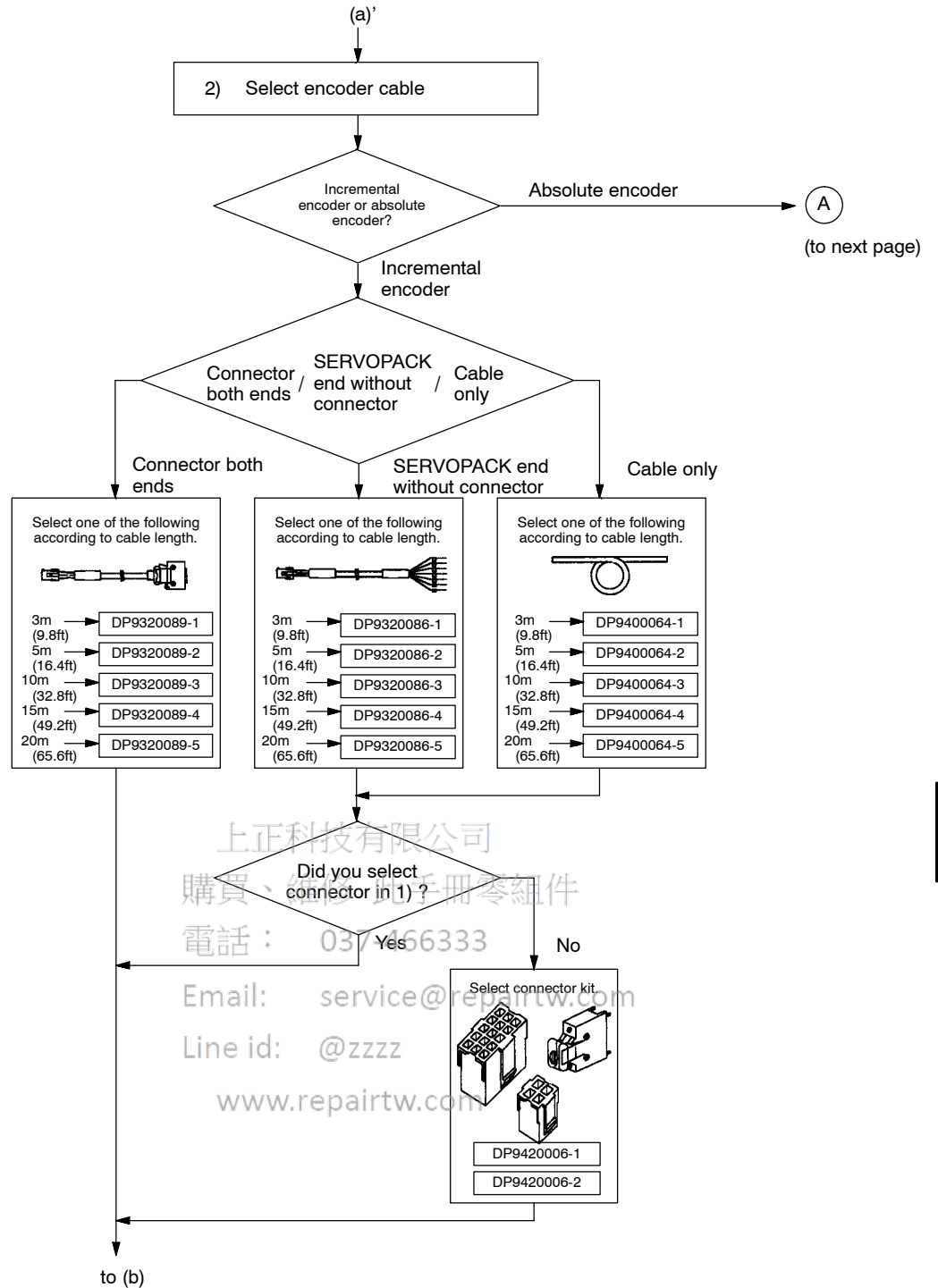

上正科技有限公司
 購買、維修此手冊零組件
 電話：03/666333
 Email: service@repairtw.com
 Line id: @zzzz
 www.repairtw.com

(A)

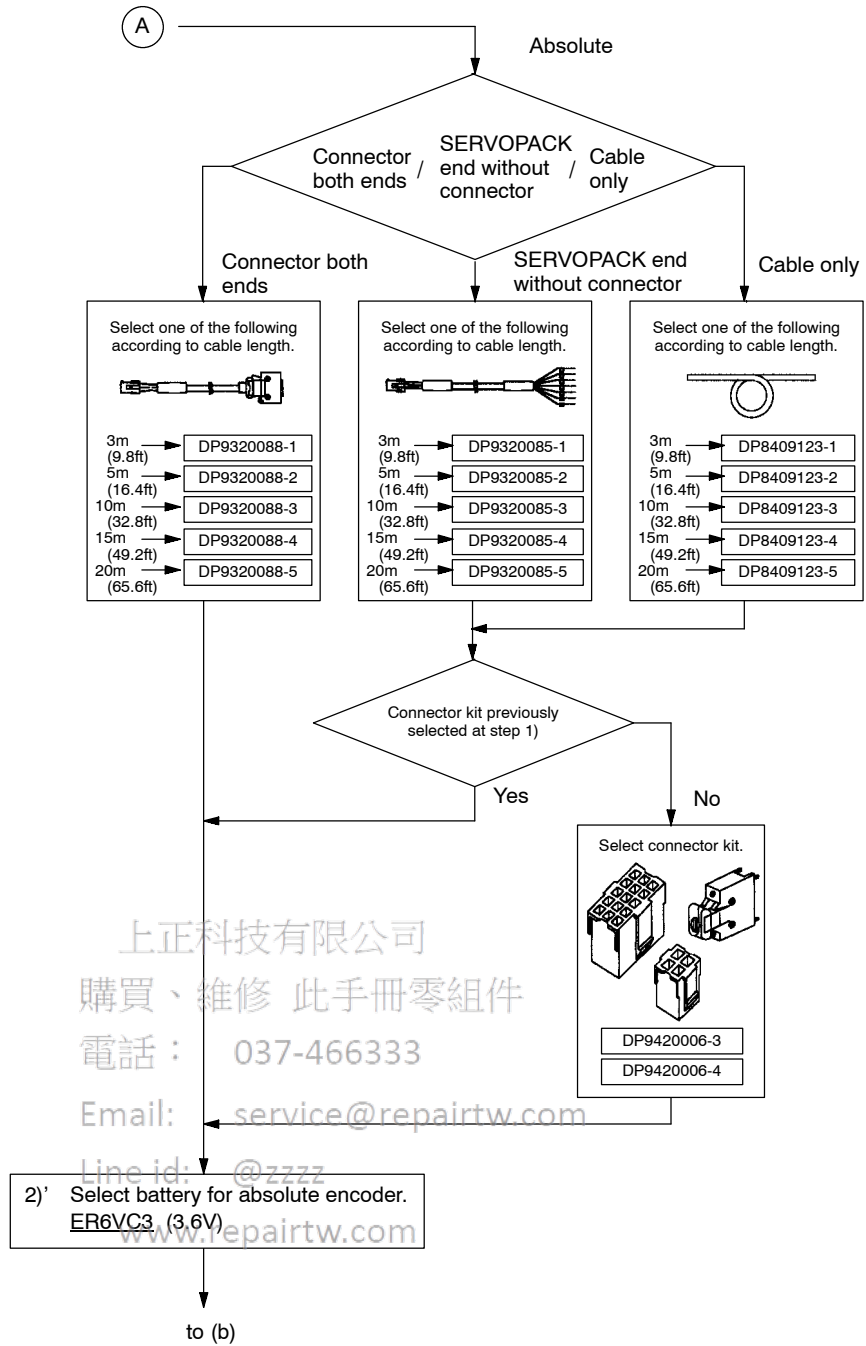

5

上正科技有限公司
 購買、維修 此手冊零組件
 電話： 037-466333
 Email: service@repairtw.com
 Line id: @zzzz

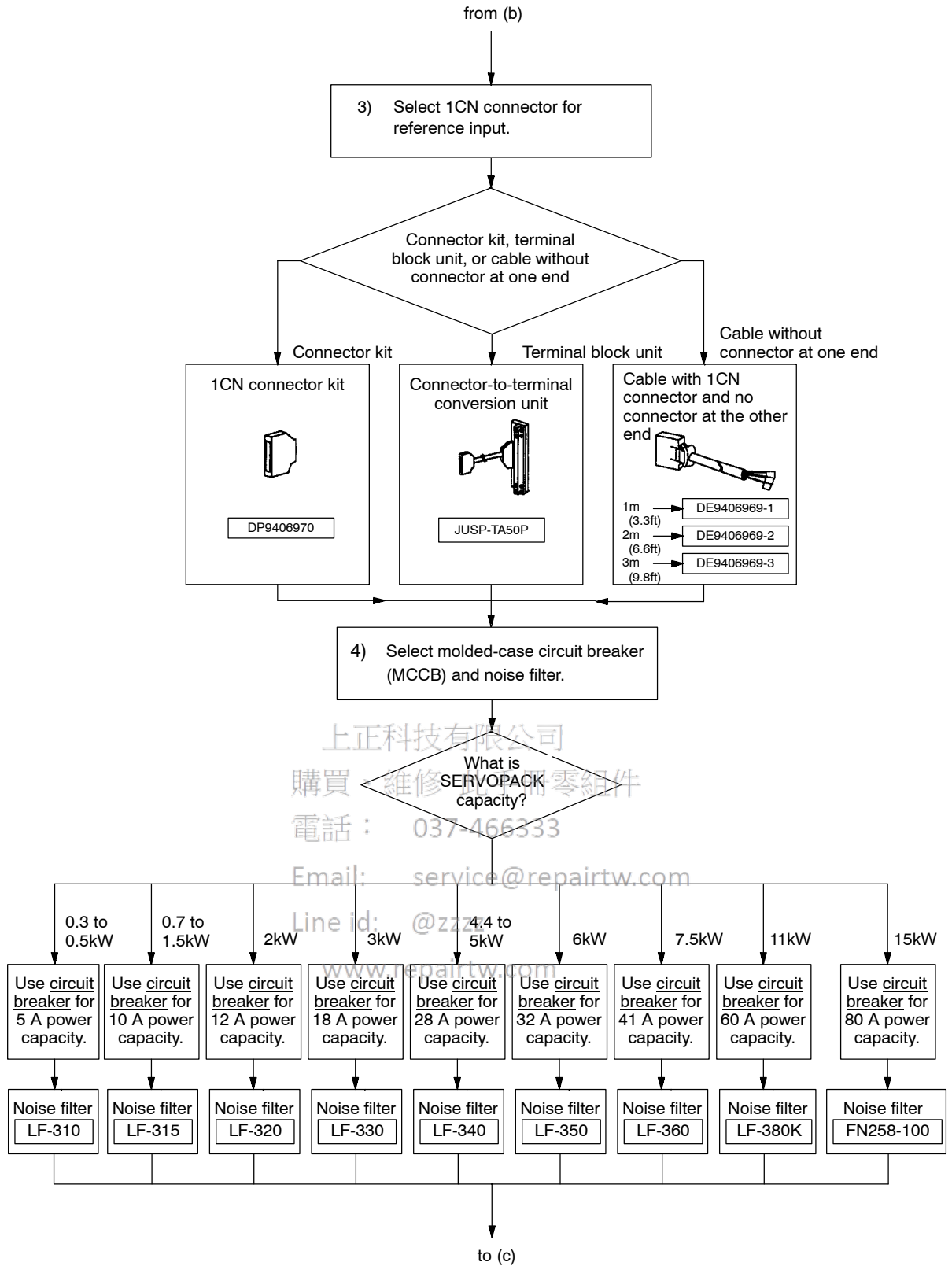

上正科技有限公司
 購買・維修・零件
 電話：037-466333
 Email: service@repairtw.com
 Line id: @zzz444

www.repairtw.com

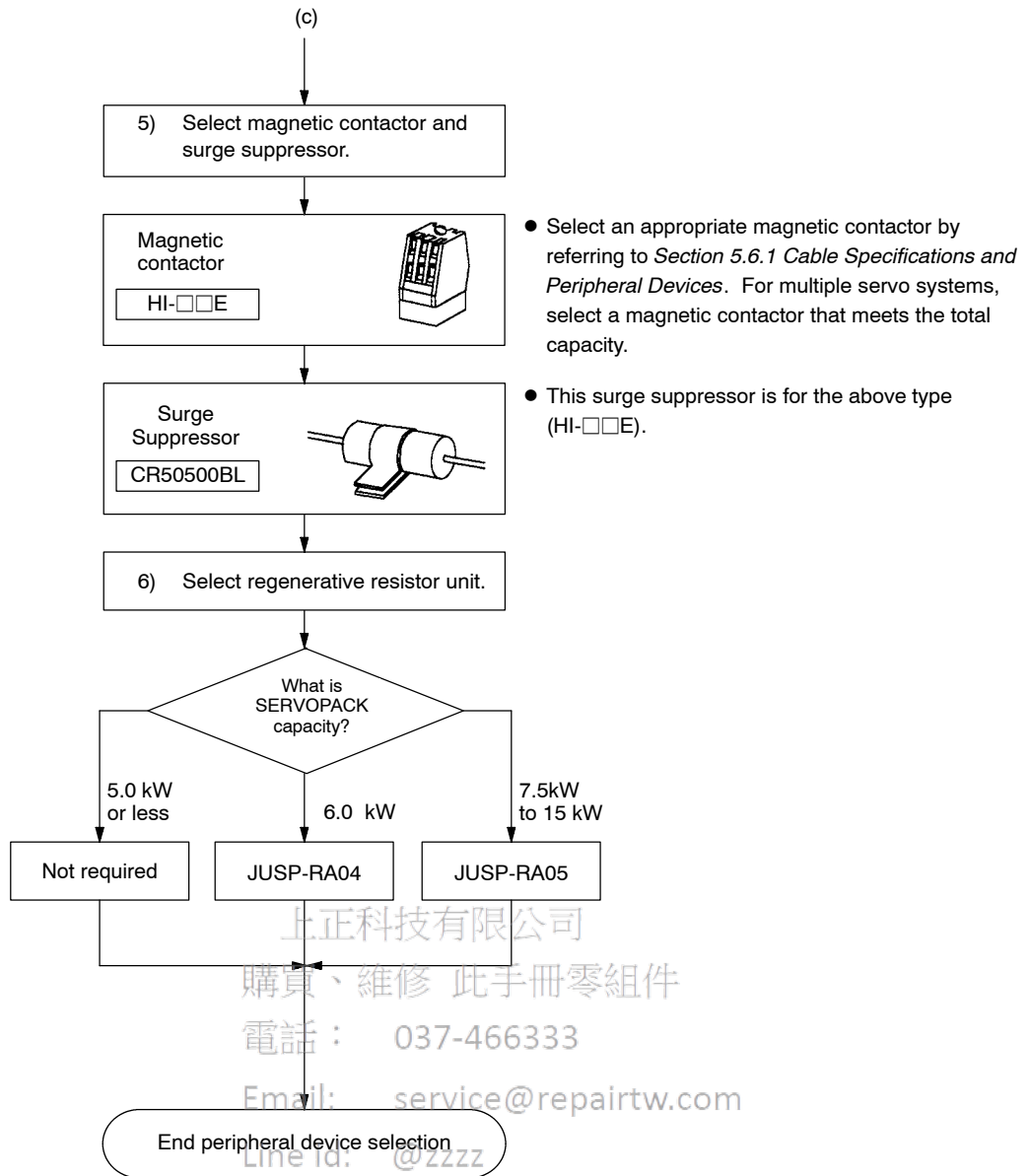

上正科技有限公司
 購買、維修 此手冊零組件
 電話： 037-466333
 Email: service@repairtw.com
 Line Id: @zzzz
 www.repairtw.com

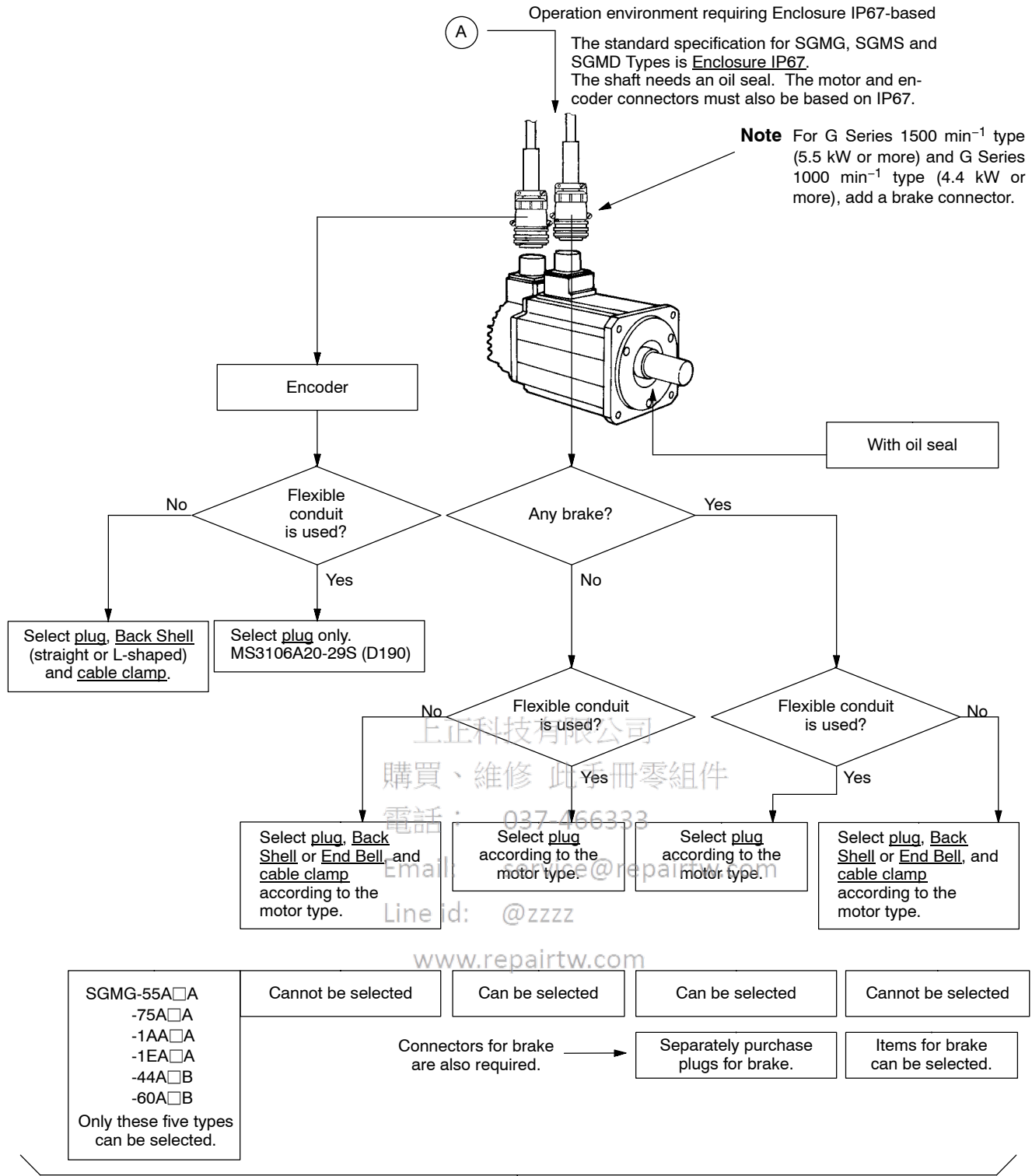

to (b)

- Note**
1. Power cable and flexible conduit must be prepared by the customer.
 2. The customer must purchase an appropriate encoder cable according to the encoder type (incremental or absolute encoder) and an encoder connector kit (for the SERVOPACK end), and assemble them.
 3. After selecting a brake power supply unit and a battery for the absolute encoder, proceed to (b) on page 421.

5.5.2 Order List

Order lists are given below for the servomotors, SERVOPACKs, digital operators, and peripheral devices which comprise the AC Servo Σ -Series. These order lists are a convenient aid to selecting peripheral devices.

■ SGM Servomotor

Servomotor Type	Qty
SGM□-□□□□□□□□	
SGM□-□□□□□□□□	
SGM□-□□□□□□□□	
SGM□-□□□□□□□□	
SGM□-□□□□□□□□	
SGM□-□□□□□□□□	
SGM□-□□□□□□□□	
SGM□-□□□□□□□□	
SGM□-□□□□□□□□	
SGM□-□□□□□□□□	
SGM□-□□□□□□□□	
SGM□-□□□□□□□□	
SGM□-□□□□□□□□	

5

■ SGDB SERVOPACK (excluding cables and connectors)

上正科技有限公司
購買、維修 此手冊零組件

SERVOPACK Type	Qty
SGDB-□□□□□	
SGDB-□□□□□	
SGDB-□□□□□	
SGDB-□□□□□	
SGDB-□□□□□	
SGDB-□□□□□	

■ Digital Operator (Purchase Separately)

Digital Operator Type	Qty
JUSP-OP02A-1	
JUSP-OP03A	

■ Peripheral Devices

For SGM, SGMS, SGMD servomotors (See page 434 for SGMP-15A servomotor)

- Connector

K11

Main Circuit Connectors on Motor Side (without Brake)

(Purchase Separately)

Motor Type	Connectors on Motor Side				Qty
	Plug		Cable Clamp	Receptacle*	
	L-shaped	Straight			
SGMS- 10A□A 15A□A 20A□A	MS3108B18-10S	MS3106B18-10S	MS3057-10A	MS3102A18-10P	
30A□A 40A□A 50A□A	MS3108B22-22S	MS3106B22-22S	MS3057-12A	MS3102A22-22P	
SGMG- 05A□A 09A□A 13A□A	MS3108B18-10S	MS3106B18-10S	MS3057-10A	MS3102A18-10P	
20A□A 30A□A 44A□A	MS3108B22-22S	MS3106B22-22S	MS3057-12A	MS3102A22-22P	
55A□A 75A□A 1AA□A 1EA□A	MS3108B32-17S	MS3106B32-17S	MS3057-20A	MS3102A32-17P	
SGMG- 03A□B 06A□B 09A□B	MS3108B18-10S	MS3106B18-10S	MS3057-10A	MS3102A18-10P	
12A□B 20A□B 30A□B	MS3108B22-22S	MS3106B22-22S	MS3057-12A	MS3102A22-22P	
44A□B 60A□B	MS3108B32-17S	MS3106B32-17S	MS3057-20A	MS3102A32-17P	
SGMD- 22A□A 32A□A 40A□A	MS3108B24-10S	MS3106B24-10S	MS3057-16A	MS3102A24-10P	

To be prepared by customer

* Connector on motor side already provided

K12

Main Circuit Connectors on Motor Side (with Brake)

(Purchase Separately)

Motor Type	Connectors on Motor Side (with Brake)				Qty
	Plug		Cable Clamp	Receptacle*	
	L-shaped	Straight			
SGMS- 10A□A 15A□A 20A□A 30A□A 40A□A 50A□A	MS3108B20-15S	MS3106B20-15S	MS3057-12A	MS3102A20-15P	
	MS3108B24-10S	MS3106B24-10S	MS3057-16A	MS3102A24-10P	
	MS3108B20-15S	MS3106B20-15S	MS3057-12A	MS3102A20-15P	
	MS3108B24-10S	MS3106B24-10S	MS3057-16A	MS3102A24-10P	
	MS3108B32-17S MS3108B10SL-3S	MS3106B32-17S MS3106A10SL-3S	MS3057-20A MS3057-4A	MS3102A32-17P MS3102A10SL-3P	
SGMG- 05A□A 09A□A 13A□A 20A□A 30A□A 44A□A 55A□A 75A□A 1AA□A 1EA□A	MS3108B20-15S	MS3106B20-15S	MS3057-12A	MS3102A20-15P	
	MS3108B24-10S	MS3106B24-10S	MS3057-16A	MS3102A24-10P	
	MS3108B32-17S MS3108B10SL-3S	MS3106B32-17S MS3106A10SL-3S	MS3057-20A MS3057-4A	MS3102A32-17P MS3102A10SL-3P	
	MS3108B20-15S	MS3106B20-15S	MS3057-12A	MS3102A20-15P	
	MS3108B24-10S	MS3106B24-10S	MS3057-16A	MS3102A24-10P	
SGMG- 03A□B 06A□B 09A□B 12A□B 20A□B 30A□B 44A□B 60A□B	MS3108B20-15S	MS3106B20-15S	MS3057-12A	MS3102A20-15P	
	MS3108B24-10S	MS3106B24-10S	MS3057-16A	MS3102A24-10P	
	MS3108B32-17S MS3108B10SL-3S	MS3106B32-17S MS3106A10SL-3S	MS3057-20A MS3057-4A	MS3102A32-17P MS3102A10SL-3P	
	MS3108B24-10S	MS3106B24-10S	MS3057-16A	MS3102A24-10P	
SGMD- 22A□A 32A□A 40A□A	MS3108B24-10S	MS3106B24-10S	MS3057-16A	MS3102A24-10P	

www.repairtw.com

To be prepared by customer

* Connector on motor side already provided

K13

Encoder Connectors on Motor Side

(Purchase Separately)

Connectors on Encoder Side				Qty
Plug		Cable Clamp	Receptacle*	
L-shaped	Straight			
MS3108B20-29S	MS3106B20-29S	MS3057-12A	MS3102A20-29P	

To be prepared by customer

* Connector on motor side already provided

K14

Encoder Connectors on SERVOPACK Side (for 2CN)

(Purchase Separately)

Connector kit on SERVOPACK Side	Connector kit				Qty
	Connector		Case		
	Type		Type		
DE9406973	10120-3000VE*	1	10320-52A0-008*	1	

* Manufactured by 3M

上正科技有限公司

購買、維修 此手冊零組件

電話： 037-466333

Email: service@repairtw.com

Line id: @zzzz

www.repairtw.com

SERVO SELECTION AND DATA SHEETS

5.5.2 Order List cont.

K15

Enclosure IP67 Main Circuit Connectors on Motor Side (without Brake)
(Purchase Separately)

Motor Type	Receptacle	Plug	End Bell: Manufactured by Japan Aviation Electronics Industry, Ltd. Back Shell: Manufactured by Daiichi Denshi Kogyo K.K.		Cable Clamp	Manufacturer	Qty
			Angle (L-shaped)	Straight			
SGMS- 10A□A 15A□A 20A□A 30A□A 40A□A 50A□A	CE05-2A18-10PD	MS3106A18-10S (D190)	CE-18BA-S	CE02-18BS-S	CE3057-10A-*	Daiichi Denshi Kogyo K.K.	
	JL04HV-2E22-22PE-B	JL04V-6A22-22SE	JL04-22EBL	JL04-22EB	JL04-2022CK (**)	Japan Aviation Electronics Industry, Ltd.	
	CE05-2A18-10PD	MS3106A18-10S (D190)	CE-18BA-S	CE02-18BS-S	CE3057-10A-*	Daiichi Denshi Kogyo K.K.	
	JL04HV-2E22-22PE-B	JL04V-6A22-22SE	JL04-22EBL	JL04-22EB	JL04-2022CK (**)	Japan Aviation Electronics Industry, Ltd.	
SGMG- 05A□A 09A□A 13A□A 20A□A 30A□A 44A□A 55A□A 75A□A 1AA□A 1EA□A	JL04V-2E32-17PE-B	JL04V-6A32-17SE	-	-	-	Japan Aviation Electronics Industry, Ltd.	
	CE05-2A18-10PD	MS3106A18-10S (D190)	CE-18BA-S	CE02-18BS-S	CE3057-10A-*	Daiichi Denshi Kogyo K.K.	
	JL04HV-2E22-22PE-B	JL04V-6A22-22SE	JL04-22EBL	JL04-22EB	JL04-2022CK (**)	Japan Aviation Electronics Industry, Ltd.	
	JL04V-2E32-17PE-B	JL04V-6A32-17SE	-	-	-	Japan Aviation Electronics Industry, Ltd.	
SGMG- 03A□B 06A□B 09A□B 12A□B 20A□B 30A□B 44A□B 60A□B	CE05-2A18-10PD	MS3106A18-10S (D190)	CE-18BA-S	CE02-18BS-S	CE3057-10A-*	Daiichi Denshi Kogyo K.K.	
	JL04HV-2E22-22PE-B	JL04V-6A22-22SE	JL04-22EBL	JL04-22EB	JL04-2022CK (**)	Japan Aviation Electronics Industry, Ltd.	
	JL04V-2E32-17PE-B	JL04V-6A32-17SE	-	-	-	Japan Aviation Electronics Industry, Ltd.	
	CE05-2A18-10PD	MS3106A18-10S (D190)	CE-18BA-S	CE02-18BS-S	CE3057-10A-*	Daiichi Denshi Kogyo K.K.	
SGMD- 22A□A 32A□A 40A□A	JL04V-2E24-10PE-B	JL04-6A24-10SE	JL04-24EBL	JL04-24EB	JL04-2428CK (**)	Japan Aviation Electronics Industry, Ltd.	

Connector on motor side already provided

To be selected if flexible conduit is used

Not required if flexible conduit is used

* Select an appropriate type according to the lead wire diameter. For details, see K17 on page 430.

To be prepared by customer

5

K16

Enclosure IP67 Main Circuit Connectors on Motor Side (with Brake)

(Purchase Separately)

Motor Type	Receptacle	Plug	End Bell: Manufactured by Japan Aviation Electronics Industry, Ltd. Back Shell: Manufactured by Daiichi Denshi Kogyo K.K.		Cable Clamp	Manufacturer	Qty	
			Angle (L-shaped)	Straight				
SGMS-	10A□A 15A□A 20A□A	JL04V-2E20-15PE-B	JL04V-6A20-15SE	JL04-20EBL	JL04-20EB	JL04-2022CK (**)	Japan Aviation Electronics Industry, Ltd.	
	30A□A 40A□A 50A□A	JL04V-2E24-10PE-B	JL04V-6A24-10SE	JL04-24EBL	JL04-24EB	JL04-2428CK (**)	Japan Aviation Electronics Industry, Ltd.	
	05A□A 09A□A 13A□A	JL04V-2E20-15PE-B	JL04V-6A20-15SE	JL04-20EBL	JL04-20EB	JL04-2022CK (**)	Japan Aviation Electronics Industry, Ltd.	
	20A□A 30A□A 44A□A	JL04V-2E24-10PE-B	JL04V-6A24-10SE	JL04-24EBL	JL04-24EB	JL04-2428CK (**)	Japan Aviation Electronics Industry, Ltd.	
	55A□A 75A□A 1AA□A 1EA□A	JL04V-2E32-17PE-B CE05-2A10SL-3PC	JL04V-6A32-17SE MS3106A10S L-3S(190)*1	- CE-10SLBA-S*	- CE05-10SLBA-S*	- CE3057-4A-1*	Japan Aviation Electronics Industry, Ltd. Daiichi Denshi Kogyo K.K.	
SGMG-	03A□B 06A□B 09A□B	JL04V-2E20-15PE-B	JL04V-6A20-15SE	JL04-20EBL	JL04-20EB	JL04-2022CK (**)	Japan Aviation Electronics Industry, Ltd.	
	12A□B 20A□B 30A□B	JL04V-2E24-10PE-B	JL04V-6A24-10SE	JL04-24EBL	JL04-24EB	JL04-2428CK (**)	Japan Aviation Electronics Industry, Ltd.	
	44A□B 60A□B	JL04V-2E32-17PE-B CE05-2A10SL-3PC	JL04V-6A32-17SE MS3106A10S L-3S(190)*1	- CE-10SLBA-S*	- CE05-10SLBA-S*	- CE3057-4A-1*	Japan Aviation Electronics Industry, Ltd. Daiichi Denshi Kogyo K.K.	
	22A□A 32A□A 40A□A	JL04V-2E24-10PE-B	JL04V-6A24-10SE	JL04-24EBL	JL04-24EB	JL04-2428CK (**)	Japan Aviation Electronics Industry, Ltd.	

Connector on motor side already provided

To be selected if flexible conduit is used

Not required if flexible conduit is used

*1 Connectors for brake power supply
* Select an appropriate type according to the lead wire diameter.

To be prepared by customer

Note For the holding brake, both L-shaped connectors and straight connectors can be used.

K17

IP67-based Encoder Connectors on Motor Side

(Purchase Separately)

Receptacle	Plug	End Bell: Manufactured by Japan Aviation Electronics Industry, Ltd. Back Shell: Manufactured by Daiichi Denshi Kogyo K.K.		Cable Clamp	Manufacturer	Qty
		Angle (L-shaped)	Straight			
97F3102E20-29P	MS3106A20-29S(D190)	CE-20BA-S	CE02-20BS-S	CE3057-12A-1*	Daiichi Denshi Kogyo K.K.	

Connector on motor side already provided

To be selected if flexible conduit is used

Not required if flexible conduit is used

* Select an appropriate type according to the lead wire diameter. See the table below.

To be prepared by customer

Note Encoder connectors on SERVOPACK side (2CN) are the same as for K14.

- Cable clamp types classified according to lead wire diameter

Cable Clamp Type	Lead Wire Diameter Range
CE3057-10A-1	ø10.5~ø14.1
CE3057-10A-2	ø8.5~ø11.0
CE3057-10A-3	ø6.5~ø8.7
CE3057-12A-1	ø12.5~ø16.0
CE3057-12A-2	ø9.5~ø13.0
CE3057-12A-3	ø6.8~ø10.0
JL04-2022CK (09)	ø6.5~ø9.5
JL04-2022CK (12)	ø9.5~ø13.0
JL04-2022CK (14)	ø12.9~ø16.0
JL04-2428CK (11)	ø9.0~ø12.0
JL04-2428CK (14)	ø12.0~ø15.0
JL04-2428CK (17)	ø15.0~ø18.0
JL04-2428CK (20)	ø18.0~ø20.0

- When flexible conduit (straight) is used:

Connector Type (Straight)	Conduit Type	Lead Wire Diameter Range
RCC-106RL-MS32F	VF-06 (SR-06)	Max. ø20
RCC-108RL-MS32F	VF-08 (SR-08)	Max. ø26
RCC-110RL-MS32F	VF-10 (SR-10)	Max. ø35
RCC-112RL-MS32F	VF-12 (SR-12)	Max. ø40
RCC-116RL-MS32F	VF-16 (SR-16)	Max. ø51

- Brake Power Supply (for Motor with Brake)

(Purchase Separately)

Brake Power Supply Type	Qty
LPSE-2H01 (for 200 V AC input)	
LPDE-1H01 (for 100 V AC input)	

- Cable

E11

Cables for Incremental Encoder

(Cable with Loose Wire End on Encoder Side)

(Purchase Separately)

Customer to attach connector on encoder side. Requires **K13** connector.

Cable Type	Qty
DE9406971-1	3m (9.8 ft)
DE9406971-2	5m (16.4 ft)
DE9406971-3	10m (32.8 ft)
DE9406971-4	15m (49.2 ft)
DE9406971-5	20m (65.6 ft)

上正科技有限公司

購買、維修、此手車零件

電話：037-466333

Email: service@repairtw.com

E12

Cables for Incremental Encoder

(Cable with Straight Plug)

(Purchase Separately)

Cable Type	Qty
DE9407234-1	3m (9.8 ft)
DE9407234-2	5m (16.4 ft)
DE9407234-3	10m (32.8 ft)
DE9407234-4	15m (49.2 ft)
DE9407234-5	20m (65.6 ft)

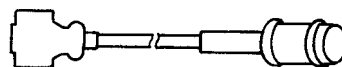

E13

Cables for Incremental Encoder

(Cable with L-shaped Plug)

(Purchase Separately)

Cable Type	Qty
DE9407235-1	3m (9.8 ft)
DE9407235-2	5m (16.4 ft)
DE9407235-3	10m (32.8 ft)
DE9407235-4	15m (49.2 ft)
DE9407235-5	20m (65.6 ft)

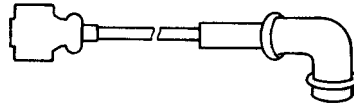

E14

Cables for Absolute Encoder

(Cable with Loose Wire End on Encoder Side)

(Purchase Separately)

Customer to attach connector on encoder side. Requires K13 connector.

Cable Type	Qty
DE9406972-1	3m (9.8 ft)
DE9406972-2	5m (16.4 ft)
DE9406972-3	10m (32.8 ft)
DE9406972-4	15m (49.2 ft)
DE9406972-5	20m (65.6 ft)

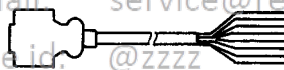

Email: service@repairtw.com

Line id: @zzzz

www.repairtw.com

E15

Cables for Absolute Encoder

(Cable with Straight Plug)

(Purchase Separately)

Cable Type	Qty
DE9407236-1	3m (9.8 ft)
DE9407236-2	5m (16.4 ft)
DE9407236-3	10m (32.8 ft)
DE9407236-4	15m (49.2 ft)
DE9407236-5	20m (65.6 ft)

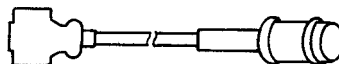

E16 Cables for Absolute Encoder

(Cable with L-shaped Plug)

(Purchase Separately)

Cable Type	Qty
DE9407237-1	3m (9.8 ft)
DE9407237-2	5m (16.4 ft)
DE9407237-3	10m (32.8 ft)
DE9407237-4	15m (49.2 ft)
DE9407237-5	20m (65.6 ft)

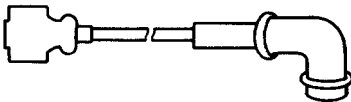

E17 Enclosure IP67 encoder cables are not available.

K17, **K14**, and cables without connector must be purchased and assembled by the customer.

- Battery for Absolute Encoder

上正科技有限公司
 購買、維修 此手冊零組件
 電話： 037-466333

(Purchase Separately)

Battery Type	Qty
ER6VC3 (3.6V)	

Line id: @zzzz

- 1CN for I/O signal

C1 1CN Connector

(Purchase Separately)

Connector Type	Qty
DE9406970	



1CN
 Connector 1CN only x 1

C2

Connector-to-terminal Conversion Unit

(Purchase Separately)

Converter Unit Type	Qty
JUSP-TA50P	

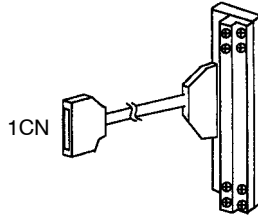

Connector 1CN and Cable (0.5 m)

C3

Cable with Connector 1CN and One End Loose Wires

(Purchase Separately)

Cable Type	Qty
DE9406969-1	1m (3.3 ft)
DE9406969-2	2m (6.6 ft)
DE9406969-3	3m (9.8 ft)



Email: service@repairtw.com

For SGMP-15A servomotors: @zzzz

- Cable

www.repairtw.com

M1

Cables for servomotor without Brake

(with connector and amplifier terminals)

(Purchase Separately)

Cable Type	Qty
DP9320827-1	3 m (9.8 ft)
DP9320827-2	5 m (16.4 ft)
DP9320827-3	10 m (32.8 ft)
DP9320827-4	15 m (49.2 ft)
DP9320827-5	20 m (65.6 ft)

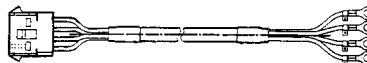

M2

Cables for Servomotor without Brake

(Cable Only)

(Purchase Separately)

Customer to attach connector and amplifier terminals. Requires **K1** connector.

Cable Type	Qty
DP9402221-1	3 m (9.8 ft)
DP9402221-2	5 m (16.4 ft)
DP9402221-3	10 m (32.8 ft)
DP9402221-4	15 m (49.2 ft)
DP9402221-5	20 m (65.6 ft)

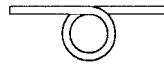

M3

Cables for Servomotor with Brake

(with connector and amplifier terminals)

(Purchase Separately)

Cable Type	Qty
DP9320828-1	3 m (9.8 ft)
DP9320828-2	5 m (16.4 ft)
DP9320828-3	10 m (32.8 ft)
DP9320828-4	15 m (49.2 ft)
DP9320828-5	20 m (65.6 ft)

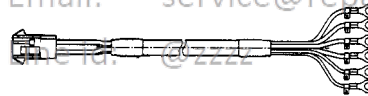
Email: service@repairtw.comwww.repairtw.com

M4 Cables for Servomotor with Brake

(Cable Only)

(Purchase Separately)

Customer to attach connector and amplifier terminals. Requires **K1** connector.

Cable Type		Qty
DP9402222-1	3 m (9.8 ft)	
DP9402222-2	5 m (16.4 ft)	
DP9402222-3	10 m (32.8 ft)	
DP9402222-4	15 m (49.2 ft)	
DP9402222-5	20 m (65.6 ft)	

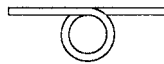

上正科技有限公司

購買、維修 此手冊零組件

電話： 037-466333

Email: service@repairtw.com

Line id: @zzzz

www.repairtw.com

- Connector

K1

Connector (for SGMP-15A)

(Purchase Separately)

Connector Kit Type	Qty
DP9420016-1 (Incremental encoder, no brake)	
DP9420016-2 (Incremental encoder, with brake)	
DP9420016-3 (Absolute encoder, no brake)	
DP9420016-4 (Absolute encoder, with brake)	

The following three connectors are supplied as a set.

- Main circuit connector on motor side: Connector for motor with or without brake x 1
- Encoder connector on motor side: Connector for incremental or absolute encoder x 1
- Encoder connector on SERVOPACK side: Connector 2CN x 1

Connectors for SGMG, SGMS and SGMD Types are provided separately. For types and other information, refer to 5.6.3 Connector.

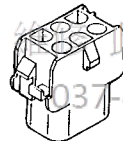
Main Circuit Connector on
Motor Side

With Brake

Encoder Connector for Motor End of Cable

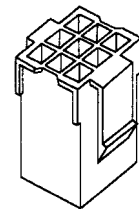

For Incremental Encoder

Email: service@repairtw.com

Line id: @zzzz

Encoder Connector for SERVOPACK End of Cable

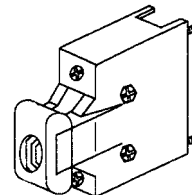
www.repairtw.com

- Brake Power Supply (for motor with brake)

(Purchase Separately)

Brake Power Supply Type	Qty
DP8401002-1 (for 200 V)	
DP8401002-2 (for 100 V)	

- Cables for Incremental Encoder

E1 Cables for Incremental Encoder

(Connector Both Ends)

(Purchase Separately)

Cable Type	Qty
DP9320089-1	3m (9.8 ft)
DP9320089-2	5m (16.4 ft)
DP9320089-3	10m (32.8 ft)
DP9320089-4	15m (49.2 ft)
DP9320089-5	20m (65.6 ft)

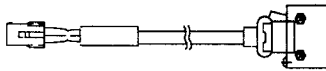

E2 Cables for Incremental Encoder

(SERVOPACK end without connectors)

(Purchase Separately)

Customer to attach connector to SERVOPACK end of cable. Requires **K1** connector.

Cable Type	Qty
DP9320086-1	3m (9.8 ft)
DP9320086-2	5m (16.4 ft)
DP9320086-3	10m (32.8 ft)
DP9320086-4	15m (49.2 ft)
DP9320086-5	20m (65.6 ft)

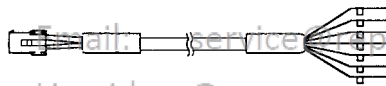

E3 Cables for Incremental Encoder

(Cable Only)

(Purchase Separately)

Customer to attach connector to both ends of cable. Requires **K1** connector.

Cable Type	Qty
B9400064-1	3m (9.8 ft)
B9400064-2	5m (16.4 ft)
B9400064-3	10m (32.8 ft)
B9400064-4	15m (49.2 ft)
B9400064-5	20m (65.6 ft)



E4

Cables for Absolute Encoder

(Connector Both Ends)

(Purchase Separately)

Cable Type	Qty
DP9320088-1	3m (9.8 ft)
DP9320088-2	5m (16.4 ft)
DP9320088-3	10m (32.8 ft)
DP9320088-4	15m (49.2 ft)
DP9320088-5	20m (65.6 ft)

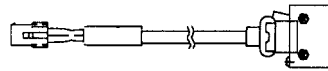

E5

Cables for Absolute Encoder

(SERVOPACK end without connector)

(Purchase Separately)

Customer to attach connector to SERVOPACK end of cable. Requires **(K1)** connector.

Cable Type	Qty
DP9320085-1	3m (9.8 ft)
DP9320085-2	5m (16.4 ft)
DP9320085-3	10m (32.8 ft)
DP9320085-4	15m (49.2 ft)
DP9320085-5	20m (65.6 ft)

Line id: @zzzz

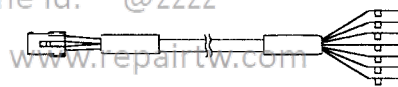

E6 Cables for Absolute Encoder

(Cable Only)

(Purchase Separately)

Customer to attach connector to both ends of cable. Requires **K1** connector.

Cable Type	Qty
DP8409123-1	3m (9.8 ft)
DP8409123-2	5m (16.4 ft)
DP8409123-3	10m (32.8 ft)
DP8409123-4	15m (49.2 ft)
DP8409123-5	20m (65.6 ft)



■ Other Peripheral Devices

- Noise Filter

(Purchase Separately)

Noise Filter Type	Qty
LF-310 (10A)	
LF-315 (15A)	
LF-320 (20A)	
LF-330 (30A)	
LF-340 (40A)	
LF-350 (50A)	
LF-360 (60A)	
LF-380K (80A)	

上止科技有限公司
 購買、維修 此手冊零組件
 電話： 037-466333
 Email: service@repairtw.com
 Line id: @zzzz

- Magnetic Contactor

www.repairtw.com

(Purchase Separately)

Magnetic Contactor Type	Qty
HI-15E5 (30A)	
HI-18E (35A)	
HI-25E (50A)	
HI-30E (65A)	
HI-35E (75A)	

- Surge Suppressor

(Purchase Separately)

Surge Suppressor Type	Qty
CR50500BL	

- Regenerative Resistor Unit

(Purchase Separately)

Regenerative Resistor Unit Type	Qty
JUSP-RA04	
JUSP-RA05	

- Variable Resistor for Speed Setting

(Purchase Separately)

Variable Resistor Type	Qty
25HP-10B	

- Cables for Connecting PC and SERVOPACK

(Purchase Separately)

Cable Type	Qty
DE9405258	2m (6.6 ft)

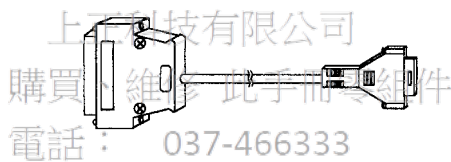

- Encoder Signal Converter Unit

Email: service@repairtw.com

Line id: @zzzz

(Purchase Separately)

www.repairtw.com

Unit Type	Qty
LRX-01/A1	
LRX-01/A2	
LRX-01/A3	
LRX-01/A4	

5.6 Specifications and Dimensional Drawings of Peripheral Devices

This section shows the specifications and dimensional drawings of the peripheral devices required for the Σ-Series servo system. The sequence of peripheral devices is given by the Flowchart for Peripheral Device Selection in *Section 5.5.1 Selecting Peripheral Devices*.

5.6.1 Cable Specifications and Peripheral Devices

The cable sizes and peripheral devices for SGDB SERVOPACKs are listed in the following tables.

The cable specifications were selected under conditions of three cables per bundle at an ambient temperature of 40°, with the rated current flowing.

■ Cable Size

External Terminal Name		SGDB Type Terminal Symbol	Cable Size (mm ²)					
			03AD	05AD	07AD	10AD	15AD	20AD
On-line Terminal	Main Circuit Power Input Terminal	R, S, T	HIV 1.25 or more		HIV 2.0 or more		HIV 3.5 or more	
	Motor Connection Terminal	U, V, W	HIV 1.25 or more		HIV 2.0 or more	HIV 3.5 or more		
	Control Power Input Terminal	r, t	HIV 1.25 or more					
Off-line Terminal	Control I/O Signal Connector	1CN	Core of twisted pair or twisted pair shield wires: 0.12 mm ² or more Outside dimensions of tinned annealed copper twisted wires: max. Ø16 (for 1CN), max. Ø11 (for 2CN)					
	PG Signal Connector	2CN						
	Ground Terminal	⊕	HIV 2.0 or more					

5

External Terminal Name		SGDB Type Terminal Symbol	Cable Size (mm ²)					
			30AD	44AD	50AD	60AD	75AD	1AAD
On-line Terminal	Main Circuit Power Input Terminal	R, S, T	HIV 3.5 or more	HIV 5.5 or more		HIV 8 or more	HIV 14 or more	HIV 22 or more
	Motor Connection Terminal	U, V, W	HIV 5.5 or more	HIV 8 or more		HIV 14 or more	HIV 22 or more	
	Control Power Input Terminal	r, t	HIV 1.25 or more					
Off-line Terminal	Control I/O Signal Connector	1CN	Core of twisted pair or twisted pair shield wires: 0.12 mm ² or more Outside dimensions of tinned annealed copper twisted wires: max. \varnothing 16 (for 1CN), max. \varnothing 11 (for 2CN)					
	PG Signal Connector	2CN						
	Ground Terminal		HIV 2.0 or more					

- Note**
- 1) Cable size selection conditions: Ambient temperature 40°C, 3 wires per bundle, and rated current flowing
 - 2) For the main circuit, use cables with a dielectric strength of 600 V or more.
 - 3) If the cables are laid in a duct (rigid PVC tube or metal pipe), allow for the reduced current rating applicable to the cables.
 - 4) If the ambient temperature (inside the control panel) is high, cables sheathed with ordinary vinyl will be easily subject to heat deterioration and become unusable in a short period of time. To prevent this, always use heat resistant cables.

The types of cable are shown in the table below. Use it in combination with the tables.

Cable Type		Conductor Allowable Temperature °C
Symbol	Name	
PVC	Normal vinyl cable	---
IV	600 V vinyl cable	60
HIV	Temperature-resistant vinyl cable	75

- Note**
- 1) Use cable with 600 V min. rating for main circuits.
 - 2) Consider allowable current reduction ratio if cables are bundled in PVC or metal ducts.
 - 3) Use temperature-resistant cable under high ambient or panel temperature where normal vinyl cables rapidly deteriorate.

SERVO SELECTION AND DATA SHEETS

5.6.1 Cable Specifications and Peripheral Devices cont.

■ Peripheral Devices

SERVOPACK type SGDB-	Motor type	Motor Selection (Cn-2A)	MCCB or fuse capacity*1	Main power Inrush current (peak value)	Recommended line filter*2	Power ON/OFF switch
03ADM	SGMG-03A□B	171	5A	28A	LF310(10A)	HI-15E5(30A)
05AD	SGM-04A	106				
05ADP	SGMP-04A	126				
05ADG	SGMG-05A□A	142				
07ADM	SGMG-06A□B	172	8A		LF315(15A)	
10AD	SGM-08A	107				
10ADP	SGMP-08A	127				
10ADG	SGMG-09A□A	143				
10ADM	SGMG-09A□B	173				
10ADS	SGMG-10A□A	163				
15ADM	SGMG-12A□B	174	10A			
15ADG	SGMG-13A□A	144				
15ADP	SGMP-15A	128				
15ADS	SGMS-15A□A	164				
20ADG	SGMG-20A□A	145	12A	56A	LF320(20A)	HI-18E(35A)
20ADM	SGMG-20A□B	175				
20ADS	SGMS-20A□A	165				
30ADD	SGMD-22A□A	155	18A		LF330(30A)	
30ADG	SGMG-30A□A	146				
30ADM	SGMG-30A□B	176				
30ADS	SGMG-30A□A	166				
44ADD	SGMD-32A□A	156	24A	58A	LF340(40A)	
44ADG	SGMG-44A□A	147				
44ADM	SGMG-44A□B	177				
44ADS	SGMS-40A□A	167				
50ADD	SGMD-40A□A	157	28A			HI-25E(50A)
50ADS	SGMS-50A□A	168				
60ADG	SGMG-55A□A	148	32A	93A	LF350(50A)	
60ADM	SGMG-60A□B	178				
75ADG	SGMG-75A□A	149	41A		LF360(60A)	HI-30E(65A)
1AADG	SGMG-1AA□A	140	60A	116A	LF380K(80A)	HI-35E(75A)
1EADG	SGMG-1EA□A	150			80A	FN258-100

*1 Braking characteristics (at 25°C): 200% for 2 s min., 700% for 0.01 s min.

*2 Yaskawa recommends noise filters manufactured by Tokin Corp and by Shaf-
fner(FN258-100). Yaskawa Controls Co., Ltd. can supply these noise filters.

NOTE

- Do not wire power lines and signal lines within the same duct, or bundle them together. Wire so that signals line are always kept apart from power lines by at least 30cm.
- Use twisted pair or multi-core twisted pair shielded wires for signal lines and the encoder (PG) feedback line. The wiring length for reference input lines must be within 3m, and for the PG feedback line within 20m.

The appropriate cables for SERVOPACK connectors 1CN and 2CN are shown in the table below.

Control I/O Signal Connector	1CN	Cable	Use twisted-pair cable or twisted-pair shielded cable.
		Applicable Cable	AWG24,26,28,30
		Finished Cable Dimensions	ø16.0 mm (ø 0.63 in.) MAX.
PG Signal Connector	2CN	Cable	Use Yaskawa cable. Use twisted-pair shielded cable if Yaskawa cable is not used.
		Applicable Cable	Applicable cable types: AWG24, 26, 28, 30. However, use AWG22 for encoder power supply and FG line. Use AWG26 for other signals. These connections permit wiring distances up to 20 m (65.6 ft).
		Finished Cable Dimensions	ø11.6 mm (ø0.46 in.) MAX.

Note Cable selection conditions: three cables per bundle at 40 °C ambient temperature, with the rated current flowing.

上正科技有限公司

購買、維修 此手冊零組件

電話： 037-466333

Email: service@repairtw.com

Line id: @zzzz

www.repairtw.com

5.6.2 Motor Cables

Select an appropriate motor cable that meets the customer's service conditions by referring to the cable specifications described in *Section 5.6.1 Cable Specifications and Peripheral Devices*.

For the SGMP servomotor (1.5 kW), order the following cables.

- Cables for Motor without Brake (with connector and AMP terminals)

Type	L in mm (feet)
DP9320827-1	3000 ^{+ 100} ₀ (10 ^{+ 0.33} ₀)
DP9320827-2	5000 ^{+ 100} ₀ (16.7 ^{+ 0.33} ₀)
DP9320827-3	10000 ^{+ 500} ₀ (33.3 ^{+ 1.67} ₀)
DP9320827-4	15000 ^{+ 500} ₀ (50 ^{+ 1.67} ₀)
DP9320827-5	20000 ^{+ 500} ₀ (66.7 ^{+ 1.67} ₀)

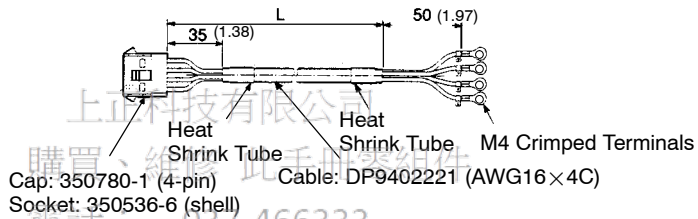

上海林科技术有限公司
 購買、維修 此手冊零件
 電話：037-466333

Email: service@repairtw.com

Line id: @zzzz

www.repairtw.com

■ Cables for Motor with Brake (with connector and AMP terminals)

Type	L in mm (feet)	
DP9320828-1	3000 $\begin{smallmatrix} + 100 \\ 0 \end{smallmatrix}$	(10 $\begin{smallmatrix} + 0.33 \\ 0 \end{smallmatrix}$)
DP9320828-2	5000 $\begin{smallmatrix} + 100 \\ 0 \end{smallmatrix}$	(16.7 $\begin{smallmatrix} + 0.33 \\ 0 \end{smallmatrix}$)
DP9320828-3	10000 $\begin{smallmatrix} + 500 \\ 0 \end{smallmatrix}$	(33.3 $\begin{smallmatrix} + 1.67 \\ 0 \end{smallmatrix}$)
DP9320828-4	15000 $\begin{smallmatrix} + 500 \\ 0 \end{smallmatrix}$	(50 $\begin{smallmatrix} + 1.67 \\ 0 \end{smallmatrix}$)
DP9320828-5	20000 $\begin{smallmatrix} + 500 \\ 0 \end{smallmatrix}$	(66.7 $\begin{smallmatrix} + 1.67 \\ 0 \end{smallmatrix}$)

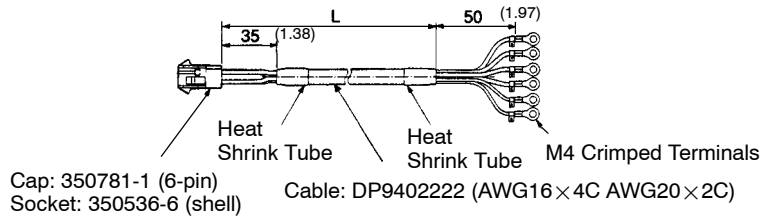

5.6.3 Connector

■ For the SGMG, SGMS, SGMD Types (See page 461 for the SGM and SGMP Types.)

Connectors are divided into the three types shown in the figure: one encoder connector at both the motor and SERVOPACK ends of the cable and a motor connector at the motor end of the cable. These connectors are common to both encoder types (incremental and absolute encoders).

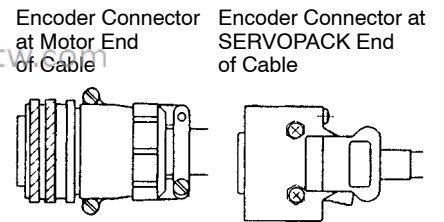

The connector type to be used differs according to the following items:

- Straight plug or L-shaped plug
- Motor with or without brake
- Standard specifications or IP67 specifications

Main Circuit (Power Line) Connector at Motor End of Cable

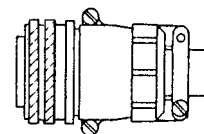

When ordering connectors, also check the motor type and capacity as they affect the connector type to be used.

To connect the motor at the SERVO-PACK end of the cable, use the crimp terminals (to be prepared by the customer).

Always order the connectors under the following conditions:

- Connectors for all cables (required regardless of whether the motor has brake or not)
- Connectors for encoder cables with a connector only on the SERVOPACK end of the cable or for encoder cables without connector (required regardless of the encoder type (incremental or absolute))
- Connectors for encoders (on the motor and SERVOPACK ends of the cable) when IP 67 specifications are used

Encoder Cables Connectors

Encoder cable connectors are divided into four types according to the following items:

- Standard specifications or IP 67 specifications
- Straight plug or L-shaped plug

			Straight Type	L-shaped (Angle) Type	Manufacturer
Standard Environment		Plug	MS3106B20-29S	MS3108B20-29S	Daiichi Denshi Kogyo K.K.
		Cable Clamp	MS3057-12A-*		
IP67-based Environment	Flexible Conduit Used	Plug Only	MS3106A20-29S (D190)	---	
	Flexible Conduit Not Used	Plug Only	MS3106A20-29S(D190)		
		Back Shell	CE02-20BS-S	CE-20BA-S	
		Cable Clamp	CE3057-12A-*		

- Examples of Connector Combination
The following examples show how to combine connectors manufactured by Daiichi Denshi Kogyo K.K.

- Standard Environment

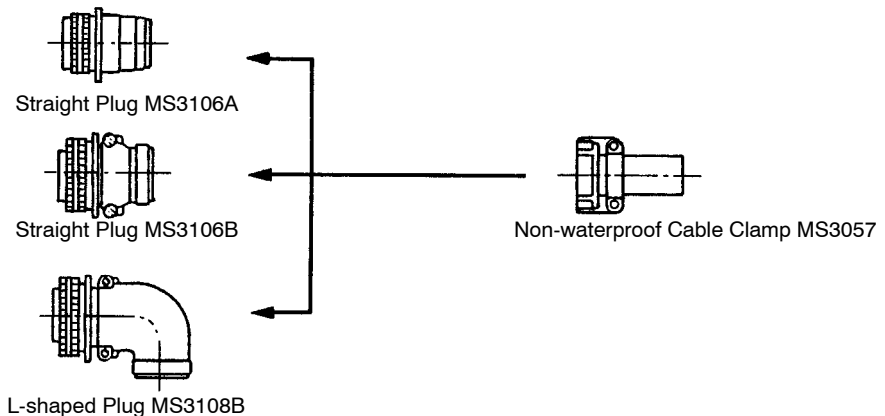

5

- IP67-based Environment

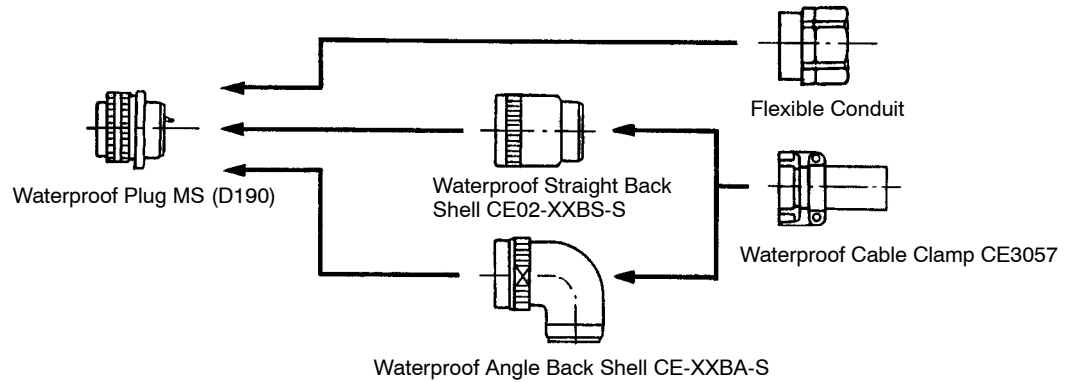

Servomotor Cables Connectors

The motor cable connectors to be used depend on the presence or absence of brake, motor type and capacity, and specifications (standard or IP67).

To connect the motor cable on the SERVOPACK side, use the crimp terminals (to be prepared by the customer).

上正科技有限公司

購買、維修 此手冊零組件

電話： 037-466333

Email: service@repairtw.com

Line id: @zzzz

www.repairtw.com

SERVO SELECTION AND DATA SHEETS

5.6.3 Connector cont.

- Standard Environment
- When using Standard Motor (without Brake)

Motor Type		Connectors on Motor Side			
		Receptacle	L-shaped Plug	Straight Plug	Cable Clamp
SGMS-	10A□A 15A□A 20A□A	MS3102A18-10P	MS3108B18-10S	MS3106B18-10S	MS3057-10A
	30A□A 40A□A 50A□A	MS3102A22-22P	MS3108B22-22S	MS3106B22-22S	MS3057-12A
SGMG-	05A□A 09A□A 13A□A	MS3102A18-10P	MS3108B18-10S	MS3106B18-10S	MS3057-10A
	20A□A 30A□A 44A□A	MS3102A22-22P	MS3108B22-22S	MS3106B22-22S	MS3057-12A
	55A□A 75A□A 1AA□A 1EA□A	MS3102A32-17P	MS3108B32-17S	MS3106B32-17S	MS3057-20A
SGMG-	03A□B 06A□B 09A□B	MS3102A18-10P	MS3108B18-10S	MS3106B18-10S	MS3057-10A
	12A□B 20A□B 30A□B	MS3102A22-22P	MS3108B22-22S	MS3106B22-22S	MS3057-12A
	44A□B 60A□B	MS3102A32-17P	MS3108B32-17S	MS3106B32-17S	MS3057-20A
	22A□A 32A□A 40A□A	MS3102A24-10P	MS3108B24-10S	MS3106B24-10S	MS3057-16A

Connector on motor side already provided

To be prepared by customer

www.repairtw.com

購買、維修 此手冊零組件
Line id: @zzzz

MS3106B Straight Plug Shell

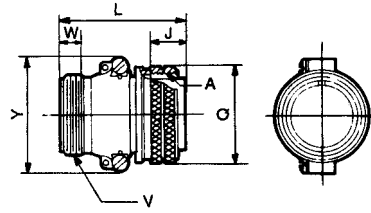

Dimensions are mm (inches)

Shell Size	Joint Screw A	Length of Joint Portion $J \pm 0.12$ (± 0.0047)	Overall Length L or less	Outside Diameter of Joint Nut $\varnothing Q$ $\begin{matrix} +0 \\ -0.38 \\ (-0.0150) \end{matrix}$	Cable Clamp Set Screw	Effective Screw Length W or more	Maximum Width Y or less
18	1 1/8-18UNEF	18.26 (0.72)	52.37 (2.06)	34.13 (1.34)	1-20UNEF	9.53 (0.38)	42 (1.65)
20	1 1/4-18UNEF	18.26 (0.72)	55.57 (2.19)	37.28 (1.47)	1 3/16-18UNEF	9.53 (0.38)	47 (1.85)
22	1 3/8-18UNEF	18.26 (0.72)	55.57 (2.19)	40.48 (1.59)	1 3/16-18UNEF	9.53 (0.38)	50 (1.97)
24	1 1/2-18UNEF	18.26 (0.72)	58.72 (2.31)	43.63 (1.72)	1 7/16-18UNEF	9.53 (0.38)	53 (2.09)
32	2-18UNS	18.26 (0.72)	61.92 (2.44)	56.33 (2.28)	1 3/4-18UNS	11.13 (0.44)	66 (2.60)

MS3108B L-Plug Shell

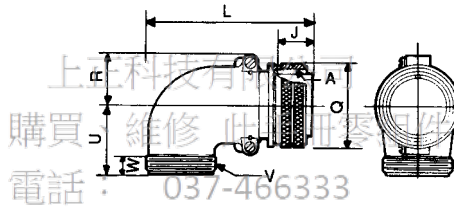

上冠科技有限
 購買 維修 此 冊 零件
 電話： 037-466333

Email: service@repairtw.com

Line id: @zzzz

Dimensions are mm (inches)

Shell Size	Joint Screw A	Length of Joint Portion $J \pm 0.12$ (± 0.0047)	Overall Length L or less	Outside Diameter of Joint Nut $\varnothing Q$ $\begin{matrix} +0 \\ -0.38 \\ (-0.0150) \end{matrix}$	$R \pm 0.5$ (0.02)	$U \pm 0.5$ (0.02)	Cable Clamp Set Screw V	Effective Screw Length W or more
10SL								
18	1 1/8-18UNEF	18.26 (0.72)	68.27 (2.69)	34.13 (1.34)	20.5 (0.81)	30.2 (1.19)	1-20UNEF	9.53 (0.38)
20	1 1/4-18UNEF	18.26 (0.72)	76.98 (3.03)	37.28 (1.45)	22.5 (0.89)	33.3 (1.31)	1 3/16-18UNEF	9.53 (0.38)
22	1 3/8-18UNEF	18.26 (0.72)	76.98 (3.03)	40.48 (1.59)	24.1 (0.95)	33.3 (1.31)	1 3/16-18UNEF	9.53 (0.38)
24	1 1/2-18UNEF	18.26 (0.72)	86.51 (3.41)	43.63 (1.72)	25.6 (1.01)	36.5 (1.44)	1 7/16-18UNEF	9.53 (0.38)
32	2-18UNS	18.26 (0.72)	95.25 (3.75)	56.33 (2.22)	32.8 (1.29)	44.4 (1.75)	1 3/4-18UNS	11.13 (0.44)

MS3106A Straight Plug Shell

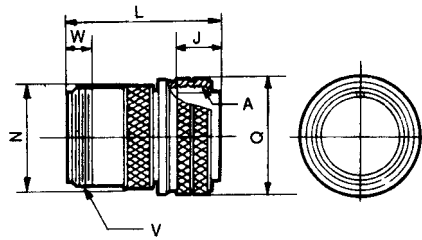

Dimensions are mm (inches)

Shell Size	Joint Screw A	Length of Joint Portion $J \pm 0.12$ (± 0.0047)	Overall Length $L \pm 1.5$ (± 0.00591)	Outside Diameter of Joint Nut ϕQ $^{+0}_{-0.38}$ (-0.0150)	$\phi N \pm 0.5$ (± 0.0197)	Cable Clamp Set Screw V	Effective Screw Length W or more
10SL	5/8-24UNEF	13.49 (0.53)	34.9 (1.37)	22.22 (0.87)	19.12 (0.75)	5/8-24UNEF	9.53(0.38)

MS3057-XXA Cable Clamp (with Rubber Bushing)

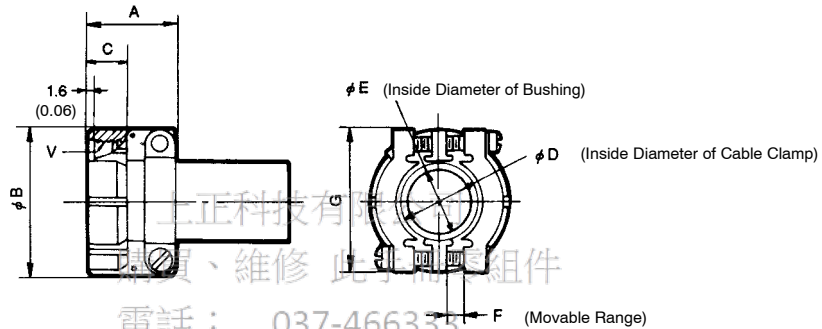

Dimensions are mm (inches)

Part Number	Shell Size of Connector	Overall Length $A \pm 0.7$ (± 0.0276)	Outside Diameter $\phi B \pm 0.7$ (± 0.0276)	Cable Clamp C	ϕD	ϕE	F	$G \pm 0.7$ (± 0.03)	Set Screw V	Attached Bushing
MS3057-4A	10SL, 12S	20.6 (0.81)	20.6 (0.81)	10.3 (0.41)	7.9 (0.31)	5.6 (0.22)	1.6 (0.06)	22.2 (0.87)	5/8-24UNEF	AN3420-4
MS3057-10A	18	23.8 (0.94)	30.1 (1.19)	10.3 (0.41)	15.9 (0.63)	14.3 (0.56)	3.2 (0.13)	31.7 (1.25)	1-20UNEF	AN3420-10
MS3057-12A	20, 22	23.8 (0.94)	35.0 (1.38)	10.3 (0.41)	19.0 (0.75)	15.9 (0.63)	4.0 (0.16)	37.3 (1.49)	13/16-18UNEF	AN3420-12
MS3057-16A	24, 28	26.2 (1.03)	42.1 (1.66)	10.3 (0.41)	23.8 (0.94)	15.9 (0.63) 19.1 (0.75)	4.8 (0.19)	42.9 (1.69)	17/16-18UNEF	AN3420-12 AN3420-16
MS3057-20A	32	27.8 (1.09)	51.6 (2.03)	11.9 (0.47)	31.7 (1.25)	19.1 (0.75) 23.8 (0.94)	6.3 (0.25)	51.6 (2.03)	13/4-18UNS	AN3420-16 AN3420-20

5

- When using Motor with Brake

Motor Type	Connectors on Motor Side			
	Receptacle	L-shaped Plug	Straight Plug	Cable Clamp
SGMS- 10A□A 15A□A 20A□A 30A□A 40A□A 50A□A	MS3102A20-15P	MS3108B20-15S	MS3106B20-15S	MS3057-12A
	MS3102A24-10P	MS3108B24-10S	MS3106B24-10S	MS3057-16A
SGMG- 05A□A 09A□A 13A□A 20A□A 30A□A 44A□A 55A□A 75A□A 1AA□A 1EA□A	MS3102A20-15P	MS3108B20-15S	MS3106B20-15S	MS3057-12A
	MS3102A24-10P	MS3108B24-10S	MS3106B24-10S	MS3057-16A
	MS3102A32-17P MS3102A10SL-3P	MS3108B32-17S MS3108B10SL-3S	MS3106B32-17S MS3106A10SL-3S	MS3057-20A MS3057-4A
SGMG- 03A□B 06A□B 09A□B 12A□B 20A□B 30A□B 44A□B 60A□B	MS3102A20-15P	MS3108B20-15S	MS3106B20-15S	MS3057-12A
	MS3102A24-10P	MS3108B24-10S	MS3106B24-10S	MS3057-16A
	MS3102A32-17P MS3102A10SL-3P	MS3108B32-17S MS3108B10SL-3S	MS3106B32-17S MS3106A10SL-3S	MS3057-20A MS3057-4A
SGMD- 22A□A 32A□A 40A□A	MS3102A24-10P	MS3108B24-10S	MS3106B24-10S	MS3057-16A

Connector on motor side already provided

To be prepared by customer

Note In the cells containing two rows, the upper row connector type is for the motor and the lower row connector type is for the brake.

- IP67-based Environment
- When Using IP67-based Motor (without Brake)

	Motor Type	Receptacle	Plug	End Bell: Manufactured by Japan Aviation Electronics Industry, Ltd. Back Shell: Manufactured by Daiichi Denshi Kogyo K.K.		Cable Clamp	Manufacturer							
				Angle (L-shaped)	Straight									
M o t o r s	SGMS- 10A□A 15A□A 20A□A	CE05-2A18-10PD	MS3106A18-10S(D190)	CE-18BA-S	CE02-18BS-S	CE3057-10A-*	Daiichi Denshi Kogyo K.K.							
								30A□A 40A□A 50A□A	JL04HV-2E2-2-22PE-B	JL04V-6A22-22SE	JL04-22EBL	JL04-22EB	JL04-2022CK (**)	Japan Aviation Electronics Industry, Ltd.
	SGMG- 05A□A 09A□A 13A□A	CE05-2A18-10PD	MS3106A18-10S(D190)	CE-18BA-S	CE02-18BS-S	CE3057-10A-*	Daiichi Denshi Kogyo K.K.							
								20A□A 30A□A 44A□A	JL04HV-2E2-2-22PE-B	JL04V-6A22-22SE	JL04-22EBL	JL04-22EB	JL04-2022CK (**)	Japan Aviation Electronics Industry, Ltd.
	SGMG- 03A□B 06A□B 09A□B	CE05-2A18-10PD	MS3106A18-10S(D190)	CE-18BA-S	CE02-18BS-S	CE3057-10A-*	Daiichi Denshi Kogyo K.K.							
								12A□B 20A□B 30A□B	JL04HV-2E2-2-22PE-B	JL04V-6A22-22SE	JL04-22EBL	JL04-22EB	JL04-2022CK (**)	Japan Aviation Electronics Industry, Ltd.
	SGMD- 22A□A 32A□A 40A□A	JL04V-2E24-10PE-B	JL04-6A24-10SE	JL04-24EBL	JL04-24EB	JL04-2428CK (**)	Japan Aviation Electronics Industry, Ltd.							

Connector on motor side already provided

To be prepared by customer

*1 The SGMG-55A□A, -75A□A, -1AA□A, -1EA□A, -44A□B, and -60A□B motors do not contain End Bell (manufactured by Japan Aviation Electronics Industry, Ltd.). For these motors, use flexible conduit instead.

- Note**
- 1) To ensure compliance with IP67, always use correct combinations of receptacles and plugs.
 - 2) End Bell is a product of Japan Aviation Electronics Industry, Ltd. Back Shell is a product of Daiichi Denshi Kogyo K.K.
 - 3) Select an appropriate cable clamp type (mark **) according to the lead wire diameter.
 - 4) When flexible conduit is used, select plug only.

• When Using IP67-based Motor (with Brake)

	Motor Type	Receptacle	Plug	End Bell: Manufactured by Japan Aviation Electronics Industry, Ltd. Back Shell: Manufactured by Daiichi Denshi Kogyo K.K.		Cable Clamp	Manufacturer
				Angle (L-shaped)	Straight		
M o t o r s	SGMS- 10A□A 15A□A 20A□A	JL04V-2E20- 15PE-B	JL04V-6A20- 15SE	JL04-20EBL	JL04-20EB	JL04-2022CK (**)	Japan Aviation Electronics Industry, Ltd.
	30A□A 40A□A 50A□A	JL04V-2E24- 10PE-B	JL04V-6A24- 10SE	JL04-24EBL	JL04-24EB	JL04-2428CK (**)	Japan Aviation Electronics Industry, Ltd.
	20A□A 30A□A 44A□A	JL04V-2E24- 10PE-B	JL04V-6A24- 10SE	JL04-24EBL	JL04-24EB	JL04-2428CK (**)	Japan Aviation Electronics Industry, Ltd.
	SGMG- 03A□B 06A□B 09A□B	JL04V-2E20- 15PE-B	JL04V-6A20- 15SE	JL04-20EB	JL04-20EB	JL04-2022CK (**)	Japan Aviation Electronics Industry, Ltd.
	44A□B 60A□B	JL04V-2E32- 17PE-B CE05-2A10S L-3PC	JL04V-6A32- 17SE MS3106A10 SL-3S(D190) *1	*2 CE-10SLBA-S *1	*2 CE05-10SLBS -S*1	*2 CE3057-4A-1* 1	Japan Aviation Electronics Industry, Ltd. Daiichi Denshi Kogyo K.K.

Connector
on motor
side already
provided

To be prepared by customer

*1 Holding brakes are applicable to both L-shaped and straight types (manufactured by Daiichi Denshi Kogyo K.K.).

End Bell is a product of Japan Aviation Electronics Industry, Ltd. Back Shell is a product of Daiichi Denshi Kogyo K.K.

*2 The SGMG-55A□A, -75A□A, -1AA□A, -1EA□A, -44A□B, and -60A□B motors do not contain End Bell (manufactured by Japan Aviation Electronics Industry, Ltd.). For these motors, use flexible conduit instead.

Note 1) To ensure compliance with IP67, always use correct combinations of receptacles and plugs.

2) When flexible conduit is used, select plug only.

**MS(D190) Series: Plug for Conduit
MS3106A20-29S (D190)**

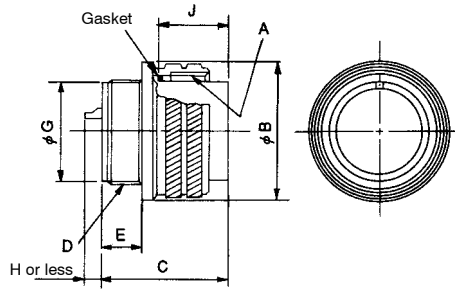

Dimensions are mm (inches)

Shell Size	A	B ⁺⁰ _{-0.38} (-0.0150)	C ± 0.5 (± 0.0197)	D	E ± 0.3 (± 0.0118)	G ^{+0.05} (+0.0020) _{-0.25} (-0.0098)	J ± 0.12 (± 0.0047)
10SL	5/8-24UNEF-2B	22.22 (0.87)	23.3 (0.92)	9/16-24UNEF-2A	7.5 (0.30)	12.5 (0.49)	13.49 (0.53)
20	1 1/4-18UNEF-2B	37.28 (1.47)	34.11 (1.34)	1 1/8-18UNEF-2A	12.16 (0.48)	26.8 (1.06)	18.26 (0.72)

Made by Daiichi Denshi Kogyo K.K.

5

**CE02-XXBS-S
Straight Back Shell (for MS(D190))**

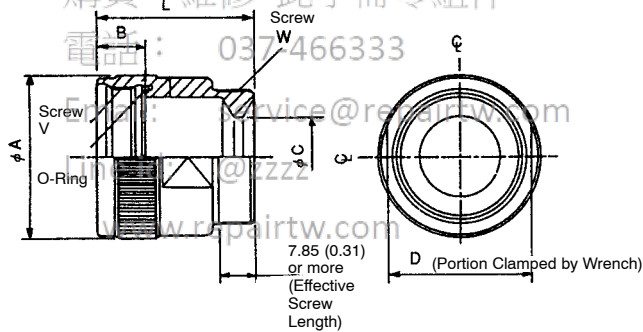

Dimensions are mm (inches)

Shell Size	Part Number	L	A	B	C	D	V	W
18	CE02-18BS-S	31 (1.22)	30.5 (1.20)	10.5 (0.41)	16.3 (0.64)	26.7 (1.05)	1-20UNEF-2B	1-20UNEF-2A
20	CE02-20BS-S	35 (1.38)	35 (1.38)	10.9 (0.41)	17.8 (0.70)	31.6 (1.24)	1 1/8-18UNEF-2B	1 3/16-18UNEF-2A

Made by Daiichi Denshi Kogyo K.K.

CE-XXBA-S (XXX)
Angle Back Shell (for MS(D190))

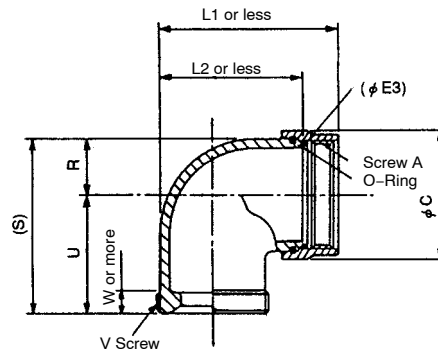

Dimensions are mm (inches)

Part Number	Shell Size	Joint Screw A	Overall Length L1	Overall Length of Angle Body L2	Outside Diameter of Coupling C	R	V	(S)	Cable Clamp Set Screw V	Effective Screw Length W
CE-10SLBA-S	10SL	9/16-24UNEF-2B	30.6 (1.20)	22.5 (0.89)	21.7 (0.85)	7.9 (0.31)	21 (0.83)	(28.9) (1.14)	5/8-24U NEF-2A	7.5 (0.30)
CE-18BA-S	18	1-20UNEF-2B	44.6 (1.76)	34 (1.34)	32.4 (1.28)	13.2 (0.52)	30.2 (1.19)	(43.4) (1.71)	1-20UN EF-2A	7.5 (0.30)
CE-20BA-S	20	1 ¹ / ₁₆ UNEF-2B	50.5 (1.99)	39.6 (1.56)	36 (1.42)	15 (0.59)	33.3 (1.31)	(48.3) (1.90)	1 ³ / ₁₆ -UN EF-2A	7.5 (0.30)

5

購買、維修 此手冊零組件

電話： 037-466333

Made by Daiichi Denshi Kogyo K.K.

Email: service@repairtw.com

CE3057-XXA (for MS(D190))
Waterproof Cable Clamp (with Rubber Bushing)

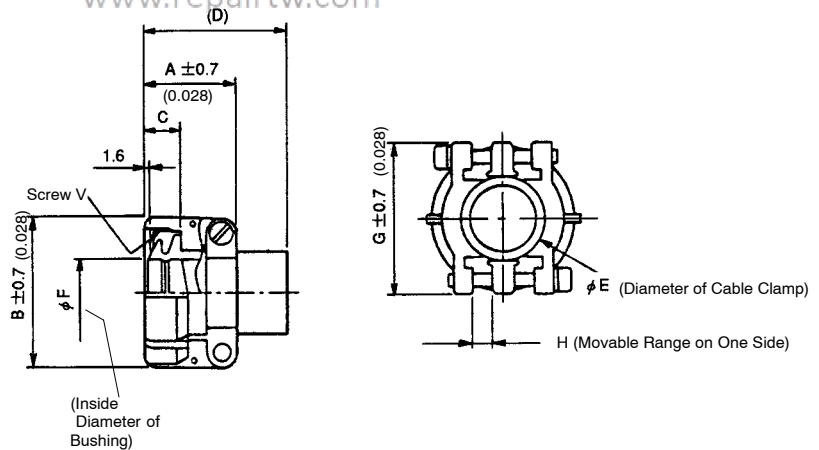

Dimensions are mm (inches)

SERVO SELECTION AND DATA SHEETS

5.6.3 Connector cont.

Part Number	Shell Size	Overall Length A	Outside Diameter B	Effective Screw Length C	(D)	E	F	G	H	Set Screw V	Attach-ed Bushing	Cable Size (for reference)		
CE3057-4A-1	10SL	20.6 (0.81)	20.6 (0.81)	10.3 (0.41)	(41.3) (1.63)	7.9 (0.31)	5.6 (0.22)	22.2 (0.87)	1.6 (0.06)	5/8-24U NEF-2B	CE3420-4-1	ø3.6 (0.14) ~ø5.6 (0.22)		
CE3057-10A-1	18	23.8 (0.94)	30.1 (1.19)	10.3 (0.41)	(41.3) (1.63)	15.9 (0.63)	14.1 (0.56)	31.7 (1.25)	3.2 (0.13)	1-20UN EF-2B	CE3420-10-1	ø10.5 (0.41) ~ø14.1 (0.56)		
CE3057-10A-2												11.6 (0.46)	CE3420-10-2	ø8.5 (0.25) ~ø11 (0.43)
CE3057-10A-3												8.7 (0.34)	CE3420-10-3	ø6.5 (0.22) ~ø8.7 (0.38)
CE3057-12A-1	20 22	23.8 (0.94)	35 (1.38)	10.3 (0.41)	(41.3) (1.63)	19 (0.75)	16 (0.63)	37.3 (1.47)	4 (0.16)	1 ³ / ₁₆ -18U NEF-2B	CE3420-12-1	ø12.5 (0.49) ~ø16 (0.63)		
CE3057-12A-2												13 (0.51)	CE3420-12-2	ø9.5 (0.37) ~ø13 (0.51)
CE3057-12A-3												10 (0.38)	CE3420-12-3	ø6.8 (0.27) ~ø10 (0.39)
CE3057-16A-1	24 28	26.2 (1.03)	42.1 (1.66)	10.3 (0.41)	(41.3) (1.63)	23.8 (0.94)	19.1 (0.75)	42.9 (1.69)	4.8 (0.19)	1 ⁷ / ₁₆ -18U NEF-2B	CE3420-16-1	ø15 (0.59) ~ø19.1 (0.75)		
CE3057-16A-2												15.5 (0.61)	CE3420-16-2	ø13 (0.51) ~ø15.5 (0.61)

5

上正科技有限公司
 電話：037-4668333
 Email: service@repairtw.com
 Line id: @zzzz

www.repairtw.com

Made by Daiichi Denshi Kogyo K.K.

Plug: JL04-6A

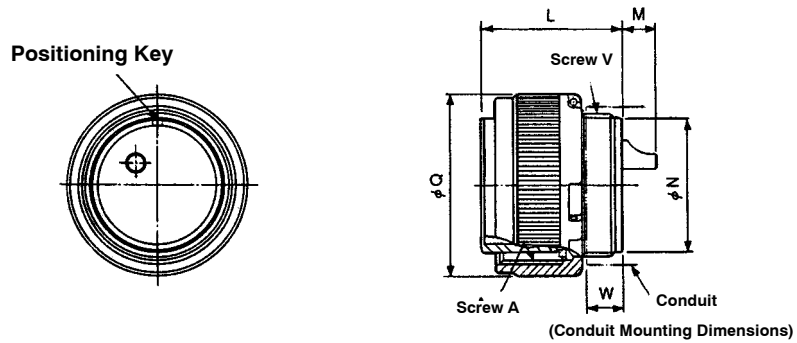

Dimensions are mm (inches)

Shell Size	No. of Cores	Parts Name	Joint Screw	$L \pm 0.4$ (0.0157)	$M \pm 0.8$ (0.0315)	$N \pm 0.2$ (0.0079)	$Q \pm 0.8$ (0.0315)	Screw V	W (max)
22	4	JL04-6A22-22S	1 $\frac{3}{8}$ -18UNEF-2B	31.5 (1.24)	7.6 (0.30)	29.6 (1.17)	40.5 (1.59)	1 $\frac{1}{4}$ -18UNEF-2A	8 (0.31)
24	7	JL04-6A24-10S	1 $\frac{1}{2}$ -18UNEF-2B	35 (1.38)	5.9 (0.23)	32.8 (1.29)	43.7 (1.72)	1 $\frac{3}{8}$ -18UNEF-2A	10 (0.39)

Made by Japan Aviation Electronics Industry, Ltd.

上正科技有限公司

Plug: JL04V-6A

購買、維修 此手冊零組件

電話：037-466333

Email: service@original.com

Line id: @zzzz

www.repairtw.com

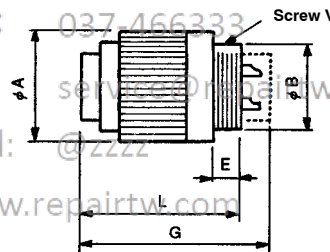

Dimensions are mm (inches)

Shell Size	Screw V	ϕA	ϕB	L	E (max)	G
20	1 $\frac{1}{8}$ -18UNEF-2A	37.3 ± 0.8 (1.47 ± 0.0315)	27 ± 0.2 (1.06 ± 0.0079)	31.5 ± 0.4 (1.24 ± 0.0157)	8 (0.32)	---
32	1 $\frac{7}{8}$ -16UN-2A	56.3 ± 0.8 (22.2 ± 0.0315)	45.4 ± 0.2 (1.79 ± 0.0079)	35.8 ± 0.4 (1.41 ± 0.0157)	10 (0.39)	---

Made by Japan Aviation Electronics Industry, Ltd.

End Bell (Straight): JL04-□□EB

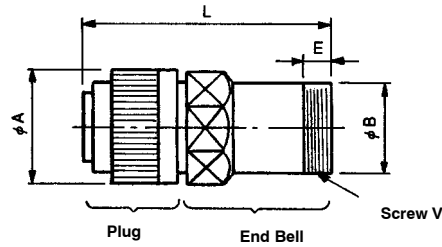

Dimensions are mm (inches)

Shell Size	Screw V	φA	φB	L	E
20	13/16-18UNEF-2A	37.3±0.8 (1.47±0.0315)	30.05±0.2 (1.18±0.0079)	67.9±0.8 (2.67±0.0315)	8 (032)
22	13/16-18UNEF-2A	40.5±0.8 (1.59)(0.0315)	30.05±0.2 (1.18)(0.0079)	67.63±0.8 (2.66±0.0315)	8 (0.32)
24	17/16-18UNEF-2A	43.7±0.8 (1.72±0.0315)	36.4±0.2 (1.43±0.0079)	71±0.8 (2.80±0.0315)	8 (0.32)

Made by Japan Aviation Electronics Industry, Ltd.

5

End Bell (L-shaped): JL04-□□EBL

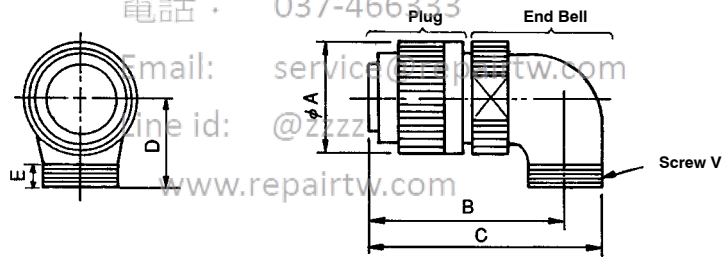

Dimensions are mm (inches)

Shell Size	Screw V	φA	B	C	D	E
20	13/16-18UNEF-2A	37.3±0.8 (1.47±0.0315)	60.5±0.8 (2.38±0.0315)	74.2±0.8 (2.92±0.0315)	32±0.8 (1.26±0.0315)	10±0.5 (0.39±0.0197)
22	13/16-18UNEF-2A	40.5±0.8 (1.59±0.0315)	60.23±0.8 (2.37±0.0315)	73.93±0.8 (2.91±0.0315)	32±0.8 (1.26±0.0315)	10±0.5 (0.39±0.0197)
24	17/16-18UNEF-2A	43.7±0.8 (1.72±0.0315)	65±0.8 (2.56±0.0315)	82±0.8 (3.23±0.0315)	38±0.8 (1.50±0.0315)	10±0.5 (0.39±0.0197)

Cable Clamp: JL04-□CK()**

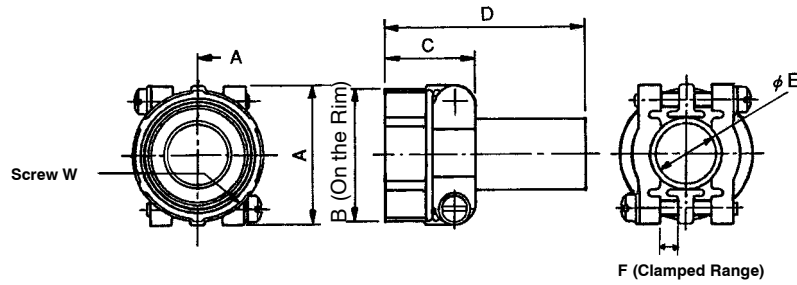

Dimensions are mm (inches)

Parts Name/Size	A ± 0.8 (± 0.0315)	B ± 0.8 (± 0.0315)	C ± 0.8 (± 0.0315)	D ± 0.8 (± 0.0315)	$\phi E \pm 0.8$ (± 0.0315)	F	Screw W	Cable Size
JL04-2022CK(14)	37.3 (1.47)	34.9 (1.37)	24.3 (0.96)	53.8 (2.11)	15.9 (0.63)	4 (0.16)	13/16-18UNEF-2B	$\phi 12.9$ (0.51) ~ $\phi 15.9$ (0.63)
JL04-2428CK(17)	42.9 (42.9)	42.1 (1.66)	26.2 (1.03)	56.2 (2.21)	18 (0.71)	4.8 (0.19)	17/16-18UNEF-2B	$\phi 15$ (0.59) ~ $\phi 18$ (0.71)

■ For the SGM and SGMP Types

Connector kit comprises three connectors as shown in the diagram below: one encoder connector at both the motor and SERVOPACK ends of the cable and a motor connector for the motor end of the cable.

Encoder Connector for Motor End of Cable

Encoder Connector for SERVOPACK End of Cable

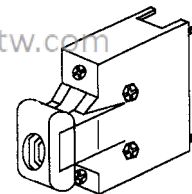
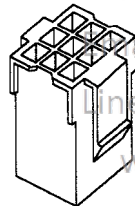

Main Circuit (Power Line) Connector on Motor Side

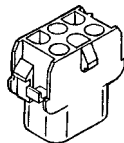

Four types of connector kit are available according to the following criteria:

- Incremental encoder or absolute encoder
- Motor with or without a brake

A connector kit is required in the following cases:

- If motor cable only is purchased (whether or not motor has a brake).
- If the encoder cable with a motor connector only and SERVOPACK end without connector, or encoder cable only is purchased (for either incremental or absolute encoder).

Encoder Cable Connectors

Select one of the following two types of encoder cable connector.

- For Incremental Encoder

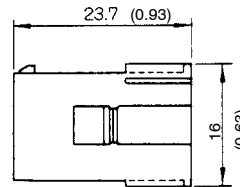
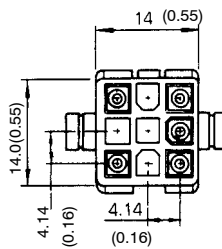

Cap: 172161-1
Socket: 170365-1

- For Absolute Encoder

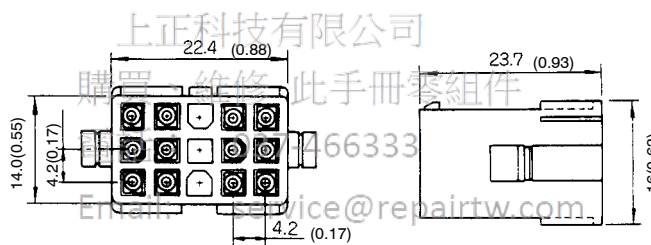

Cap: 172163-1
Socket: 170361-1 or 170365-1

Servomotor Cable Connectors

Select one of the following two types of motor cable connector.

- Motor Without Brake

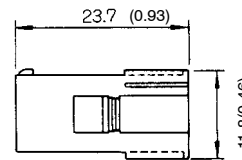
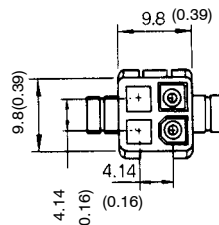

Cap: 172159-1
Socket: 170362-1 or 170366-1

• Motor With Brake

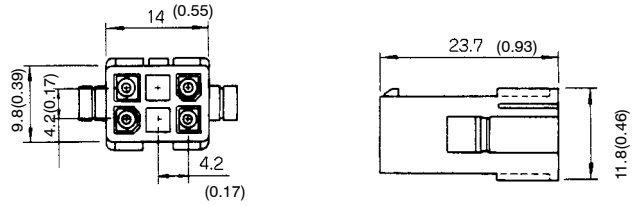

Cap: 172160-1
Socket: 170362-1 or 170366-1

■ For SGMP-15A Type Only

• Motor Without Brake

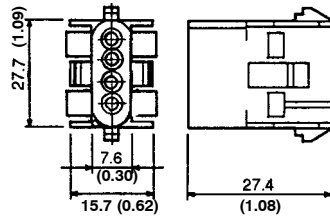

Cap: 350780-1
Socket: 350536-6 or 350550-6

• Motor With Brake

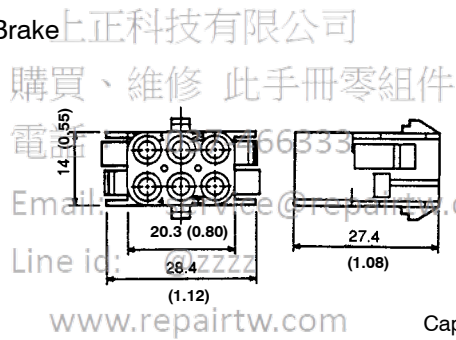

Cap: 350781-1
Socket: 350536-6 or 350550-6

上正科技有限公司
購買、維修 此手冊零組件
電話: 02-26653333
Email: service@repairtw.com
Line id: @ZZZZZ
www.repairtw.com

- Common to the SGMG, SGMS, SGMD, SGM and SGMP Types

Only one type of encoder connector is available for the SERVOPACK end of the cable.

- Connector

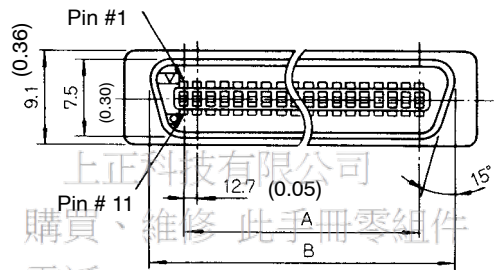
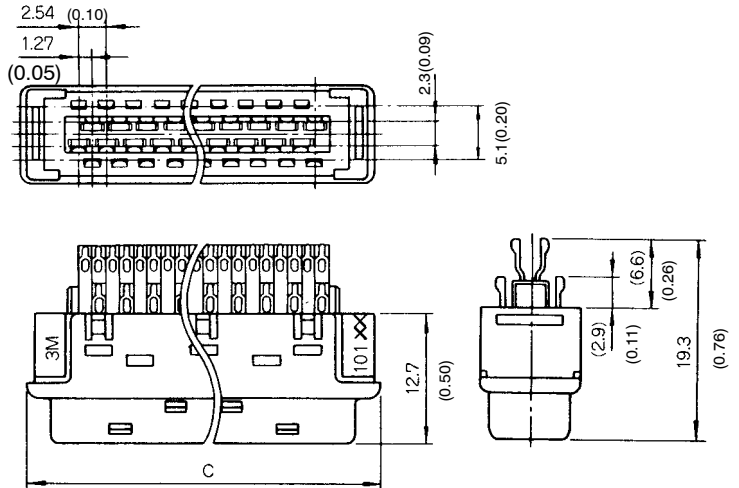

上正科技有限公司
 購買、維修 此手冊零組件
 電話： 037-466333
 Email: service@repairtw.com
 Line id: @zzzz

Units: mm (inches)

Connector Type	A	B	C
10120-3000VE	11.43 (0.45)	17.6 (0.69)	22.0 (0.87)

Manufactured by 3M.

• Case

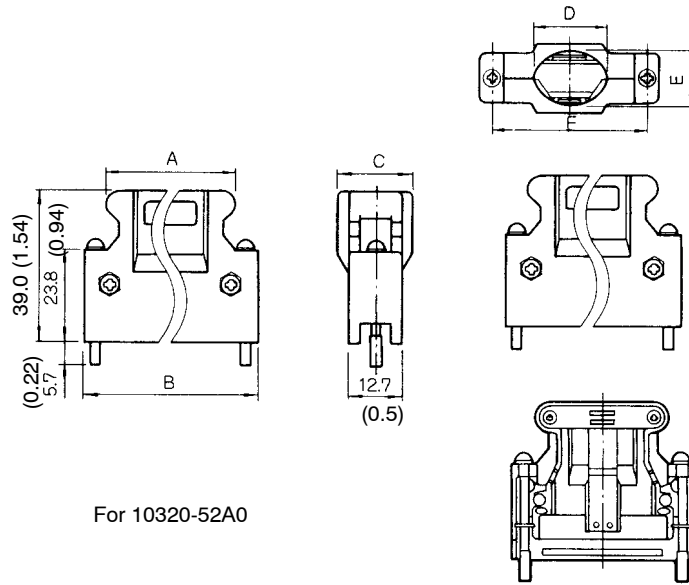

For 10320-52A0

Diagram of Assembled Connector (for reference)

Units: mm (inches)

Connector Kit Type	Connector	Case	A	B	C	D	E	F
DE9406973	10120-3000VE	10320-52A0-008	22.0 (0.87)	33.3 (1.31)	14.0 (0.55)	12.0 (0.47)	10.0 (0.39)	27.4 (1.08)

Manufactured by 3M.

Connector Combinations

- For SGM and SGMP Types

The following table shows connector combinations applicable to the SGM and SGMP types. Combine the connectors selected in page 462 to 464.

Connector Kit Type	Application		Connector Kit Part List											
			For Encoder Cable					For Motor Cable						
	Encoder Type	Motor Brake With/Without	Encoder End		SERVOPACK End				Cap		Socket			
			Type	Qty	Type	Qty	Connector	Case	Type	Qty	Type	Qty	Type	Qty
DP9420006-1	Incremental	Without	*1	1	*1	*3	*2	1	*2	1	*1	1	*1	*3
			172161		170365	10	10120-3000VE	10320-52A0-008	172159		170366		5	
DP9420006-2	Incremental	With	-1		-1				-1		-1		7	
									*1	1			*3	
DP9420006-3	Absolute	Without	*1	1		*3			*1	1			*3	
			172163			16			172159				5	
DP9420006-4	Absolute	With	-1										*3	
									*1	1			7	
									172160				7	

5.6.4 Brake Power Supply

*1 Manufactured by AMP.

*2 Manufactured by 3M.

*3 Including one spare.

• For SGMP-15A Type

Connector Kit Type	Application		Connector Kit Part List											
	Encoder/Motor Cable		For Encoder Cable								For Motor Cable			
	Encoder Type	Motor Brake With/Without	Encoder End				SERVOPACK End				Cap		Socket	
			Cap		Socket		Connector		Case		Type	Qty	Type	Qty
Type			Qty	Type	Qty	Type	Qty	Type	Qty	Type	Qty	Type	Qty	
DP9420016-1	Incremental	Without	*1	1	*1	*3	*2	1	*2	1	*1	1	*1	*3
			172161-1		170365-1	10	10120-3000VE		10320-52A0-008		350780-1		350550-6	5
DP9420016-2	Incremental	With									*1	1		*3
											350781-1			7
DP9420016-3	Absolute	Without	*1	1		*3					*1	1		*3
			172163-1			16					350780-1			5
DP9420016-4	Absolute	With									*1	1		*3
											350781-1			7

5

上正科技有限公司

*1 Manufactured by AMP.

購買、維修 此手冊零組件

*2 Manufactured by 3M.

電話： 037-466333

Email: service@repairtw.com

*3 Including one spare.

Line id: @zzzz

www.repairtw.com

5.6.4 Brake Power Supply

Brake power supplies are available for 200 V and 100 V input.

200 VAC Input: LPSE-2H01

100 VAC Input: LPDE-1H01

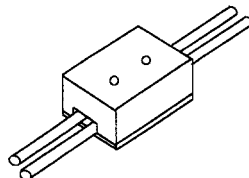

Use for servomotor with brake.

• Dimensional Drawings

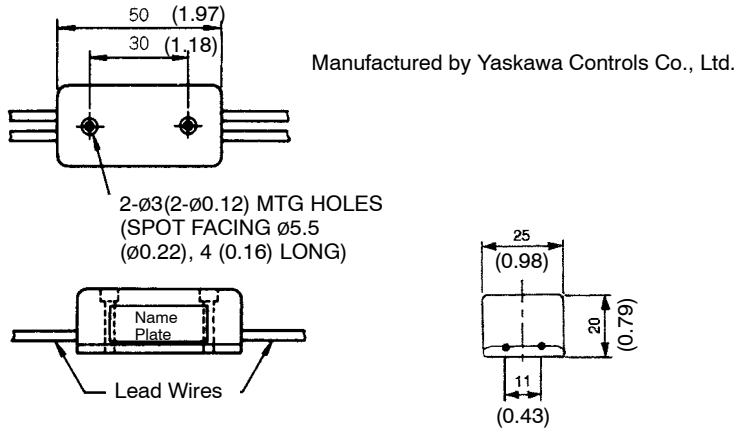

Dimensions in mm (inches)

- Lead Wire Length: 500 mm each (19.69 in.)
- Max. Ambient Temperature: 60°C
- Lead Wires: Color Code

AC Input		Brake
100V	200V	
Blue/White	Yellow/White	Red/Black

5

NOTE The internal circuits are shown below. While it is possible to switch either the AC or DC side of the brake power supply, it is normally safer to switch the AC side. If the DC side is to be switched, install a surge suppressor near the brake coil to prevent the surge voltages due to switching the DC side damaging the brake coil. Brake operation time delay occurs during brake power supply ON/OFF operation. Set output timing of servo OFF operation (motor output stop), referring to "3.4.4 Using Holding Brake." Especially, if the AC side of the brake power supply is to be switched, brake operation time is extended.

- Internal Circuit for 200 VAC Input (LPSE-2H01)

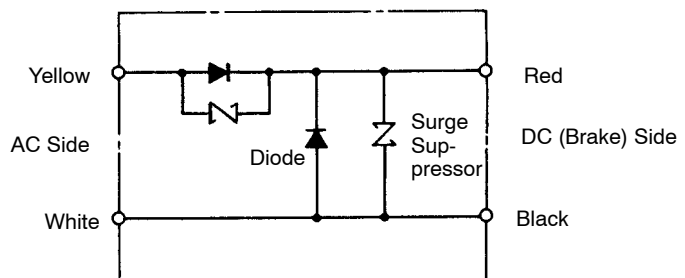

- Internal Circuit for 100 VAC Input (LPDE-1H01)

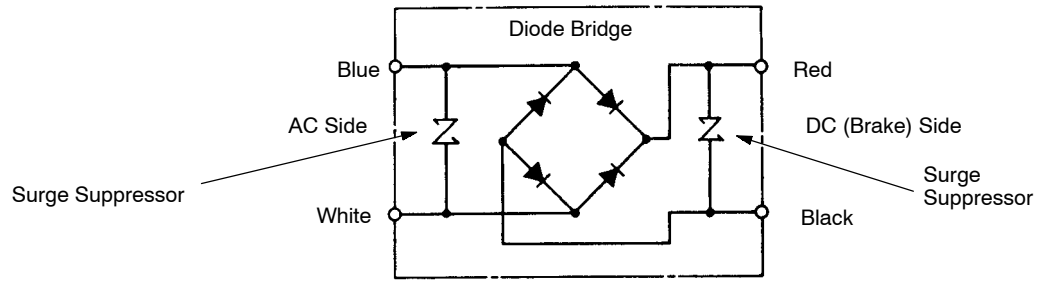

上正科技有限公司

購買、維修 此手冊零組件

電話： 037-466333

Email: service@repairtw.com

Line id: @zzzz

www.repairtw.com

5.6.5 Encoder Cables

The dimensions and appearance of the encoder cables are shown below. Specify the cable type when ordering.

- For the SGMG, SGMS and SGMD Types (See page 475 for the SGM and SGMP Types.)

Cables for Incremental Encoder (with Straight Plug)

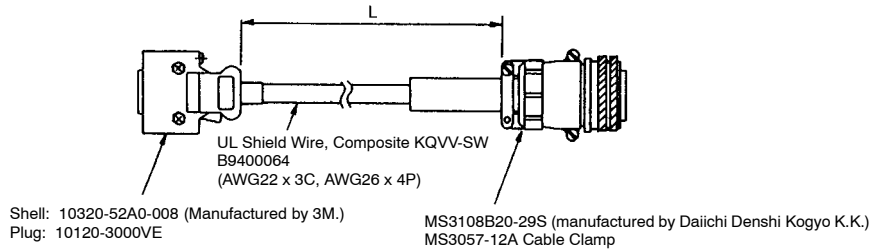

Type	L in mm (feet)
DE9407234-1	3000 $\begin{smallmatrix} + 100 \\ 0 \end{smallmatrix}$ (10 $\begin{smallmatrix} + 0.33 \\ 0 \end{smallmatrix}$)
DE9407234-2	5000 $\begin{smallmatrix} + 100 \\ 0 \end{smallmatrix}$ (16.7 $\begin{smallmatrix} + 0.33 \\ 0 \end{smallmatrix}$)
DE9407234-3	10000 $\begin{smallmatrix} + 500 \\ 0 \end{smallmatrix}$ (33.3 $\begin{smallmatrix} + 1.67 \\ 0 \end{smallmatrix}$)
DE9407234-4	15000 $\begin{smallmatrix} + 500 \\ 0 \end{smallmatrix}$ (50 $\begin{smallmatrix} + 1.67 \\ 0 \end{smallmatrix}$)
DE9407234-5	20000 $\begin{smallmatrix} + 500 \\ 0 \end{smallmatrix}$ (66.7 $\begin{smallmatrix} + 1.67 \\ 0 \end{smallmatrix}$)

5

Cables for Incremental Encoder (with L-shaped Plug)

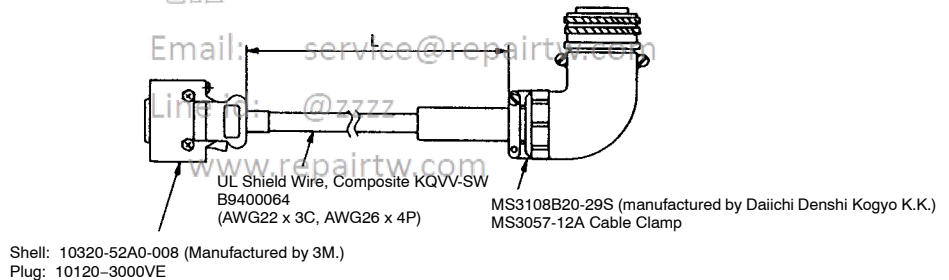

Type	L in mm (feet)
DE9407235-1	3000 $\begin{smallmatrix} + 100 \\ 0 \end{smallmatrix}$ (10 $\begin{smallmatrix} + 0.33 \\ 0 \end{smallmatrix}$)
DE9407235-2	5000 $\begin{smallmatrix} + 100 \\ 0 \end{smallmatrix}$ (16.7 $\begin{smallmatrix} + 0.33 \\ 0 \end{smallmatrix}$)
DE9407235-3	10000 $\begin{smallmatrix} + 500 \\ 0 \end{smallmatrix}$ (33.3 $\begin{smallmatrix} + 1.67 \\ 0 \end{smallmatrix}$)
DE9407235-4	15000 $\begin{smallmatrix} + 500 \\ 0 \end{smallmatrix}$ (50 $\begin{smallmatrix} + 1.67 \\ 0 \end{smallmatrix}$)
DE9407235-5	20000 $\begin{smallmatrix} + 500 \\ 0 \end{smallmatrix}$ (66.7 $\begin{smallmatrix} + 1.67 \\ 0 \end{smallmatrix}$)

Cables for Incremental Encoder (without Connector on Encoder End)

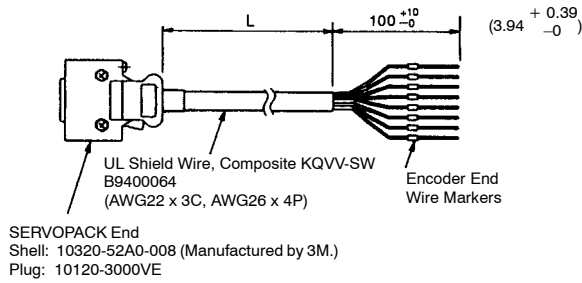

Type	L in mm (feet)
DE9406971-1	3000 $\begin{matrix} + 100 \\ 0 \end{matrix}$ (10 $\begin{matrix} + 0.33 \\ 0 \end{matrix}$)
DE9406971-2	5000 $\begin{matrix} + 100 \\ 0 \end{matrix}$ (16.7 $\begin{matrix} + 0.33 \\ 0 \end{matrix}$)
DE9406971-3	10000 $\begin{matrix} + 500 \\ 0 \end{matrix}$ (33.3 $\begin{matrix} + 1.67 \\ 0 \end{matrix}$)
DE9406971-4	15000 $\begin{matrix} + 500 \\ 0 \end{matrix}$ (50 $\begin{matrix} + 1.67 \\ 0 \end{matrix}$)
DE9406971-5	20000 $\begin{matrix} + 500 \\ 0 \end{matrix}$ (66.7 $\begin{matrix} + 1.67 \\ 0 \end{matrix}$)

5

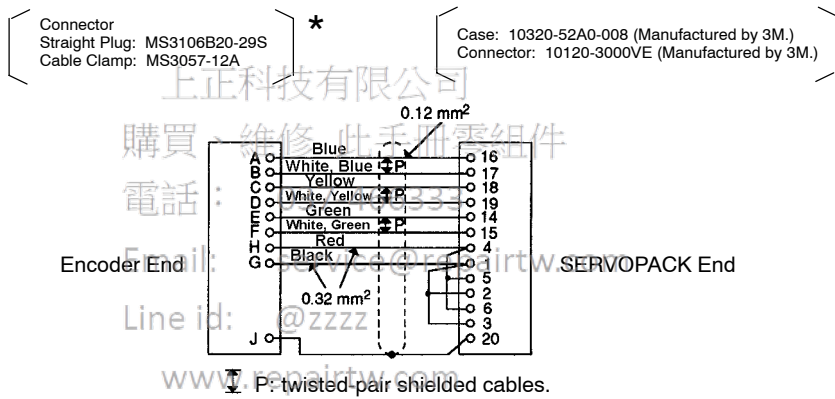

*Purchase cases and connectors separately. Refer to Section 5.6.3 Connector for details.

Cables for Absolute Encoder (with Straight Plug)

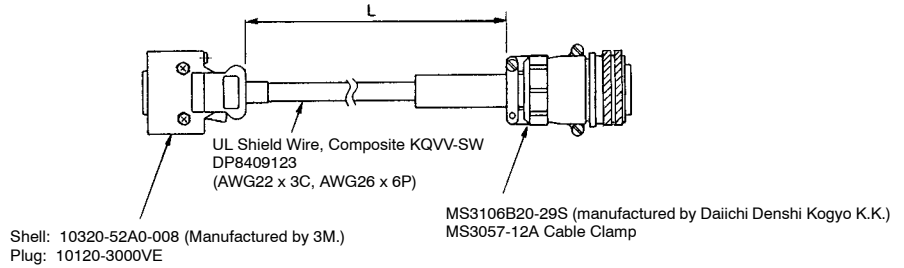

Type	L in mm (feet)	
DE9407236-1	3000 ^{+ 100} ₀	(10 ^{+ 0.33} ₀)
DE9407236-2	5000 ^{+ 100} ₀	(16.7 ^{+ 0.33} ₀)
DE9407236-3	10000 ^{+ 500} ₀	(33.3 ^{+ 1.67} ₀)
DE9407236-4	15000 ^{+ 500} ₀	(50 ^{+ 1.67} ₀)
DE9407236-5	20000 ^{+ 500} ₀	(66.7 ^{+ 1.67} ₀)

Cables for Absolute Encoder (with L-shaped Plug)

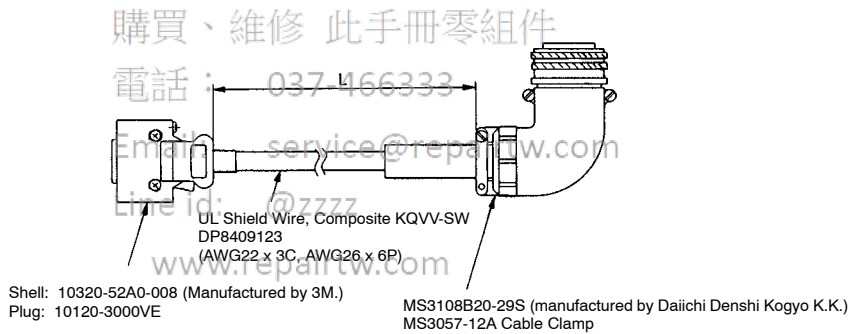

Type	L in mm (feet)	
DE9407237-1	3000 ^{+ 100} ₀	(10 ^{+ 0.33} ₀)
DE9407237-2	5000 ^{+ 100} ₀	(16.7 ^{+ 0.33} ₀)
DE9407237-3	10000 ^{+ 500} ₀	(33.3 ^{+ 1.67} ₀)
DE9407237-4	15000 ^{+ 500} ₀	(50 ^{+ 1.67} ₀)
DE9407237-5	20000 ^{+ 500} ₀	(66.7 ^{+ 1.67} ₀)

Cables for Absolute Encoder (without Connector on Encoder End)

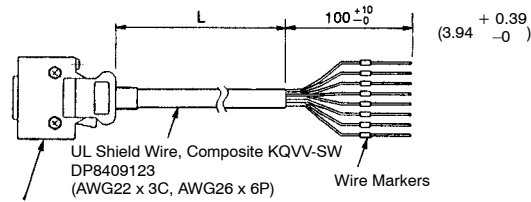

Shell: 10320-52A0-008 (Manufactured by 3M.)
 Plug: 10120-3000VE

Type	L in mm (feet)	
DE9406972-1	3000 ^{+ 100} / ₀	(10 ^{+ 0.33} / ₀)
DE9406972-2	5000 ^{+ 100} / ₀	(16.7 ^{+ 0.33} / ₀)
DE9406972-3	10000 ^{+ 500} / ₀	(33.3 ^{+ 1.67} / ₀)
DE9406972-4	15000 ^{+ 500} / ₀	(50 ^{+ 1.67} / ₀)
DE9406972-5	20000 ^{+ 500} / ₀	(66.7 ^{+ 1.67} / ₀)

5

Connector: Straight Plug: MS3106B20-29S
 Cable Clamp: MS3057-12A

Case: 10320-52A0-008 (Manufactured by 3M.)
 Connector: 10120-3000VE (Manufactured by 3M.)

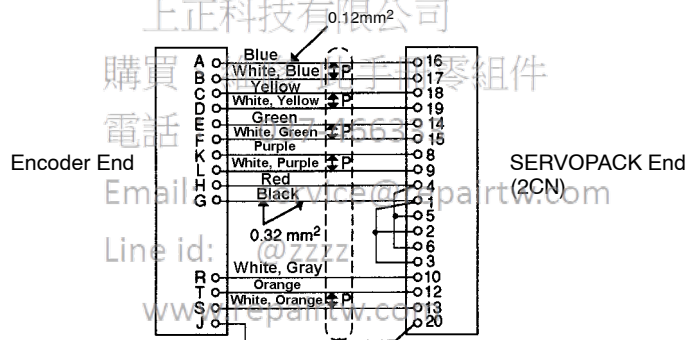

⚡ P: twisted-pair shielded cables.

*Purchase cases and connectors separately. Refer to Section 5.6.3 Connector for details.

Cables for Incremental Encoder (without Connector on Both Ends)

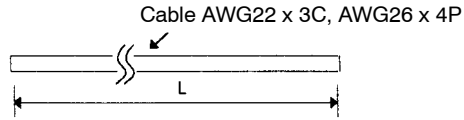

Type	L in mm (feet)
B9400064-1	3000 $\begin{smallmatrix} + 100 \\ 0 \end{smallmatrix}$ (10 $\begin{smallmatrix} + 0.33 \\ 0 \end{smallmatrix}$)
B9400064-2	5000 $\begin{smallmatrix} + 100 \\ 0 \end{smallmatrix}$ (16.7 $\begin{smallmatrix} + 0.33 \\ 0 \end{smallmatrix}$)
B9400064-3	10000 $\begin{smallmatrix} + 500 \\ 0 \end{smallmatrix}$ (33.3 $\begin{smallmatrix} + 1.67 \\ 0 \end{smallmatrix}$)
B9400064-4	15000 $\begin{smallmatrix} + 500 \\ 0 \end{smallmatrix}$ (50 $\begin{smallmatrix} + 1.67 \\ 0 \end{smallmatrix}$)
B9400064-5	20000 $\begin{smallmatrix} + 500 \\ 0 \end{smallmatrix}$ (66.7 $\begin{smallmatrix} + 1.67 \\ 0 \end{smallmatrix}$)

Connector
Straight Plug: MS3106B20-29S
Cable Clamp: MS3057-12A

Case: 10320-52A0-008 (Manufactured by 3M.)
Connector: 10120-3000VE (Manufactured by 3M.)

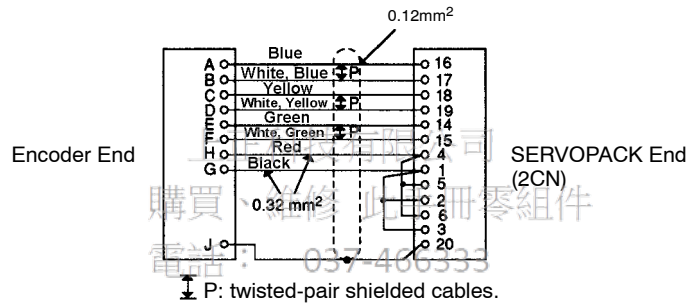

* Purchase caps, sockets, cases, and connectors separately. Refer to *Section 5.6.3 Connector* for details. www.repairtw.com

a) Cables for Absolute Encoder (Cable Only)

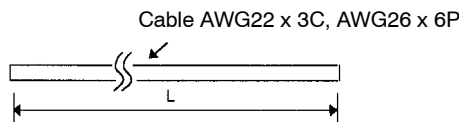

SERVO SELECTION AND DATA SHEETS

5.6.5 Encoder Cables cont.

Type	L in mm (feet)
DP8409123-1	3000 $\begin{smallmatrix} + 100 \\ 0 \end{smallmatrix}$ (10 $\begin{smallmatrix} + 0.33 \\ 0 \end{smallmatrix}$)
DP8409123-2	5000 $\begin{smallmatrix} + 100 \\ 0 \end{smallmatrix}$ (16.7 $\begin{smallmatrix} + 0.33 \\ 0 \end{smallmatrix}$)
DP8409123-3	10000 $\begin{smallmatrix} + 500 \\ 0 \end{smallmatrix}$ (33.3 $\begin{smallmatrix} + 1.67 \\ 0 \end{smallmatrix}$)
DP8409123-4	15000 $\begin{smallmatrix} + 500 \\ 0 \end{smallmatrix}$ (50 $\begin{smallmatrix} + 1.67 \\ 0 \end{smallmatrix}$)
DP8409123-5	20000 $\begin{smallmatrix} + 500 \\ 0 \end{smallmatrix}$ (66.7 $\begin{smallmatrix} + 1.67 \\ 0 \end{smallmatrix}$)

Connector
Straight Plug: MS3106B20-29S
Cable Clamp: MS3057-12A *

Case: 10320-52A0-008 (Manufactured by 3M.)
Connector: 10120-3000VE (Manufactured by 3M.) *

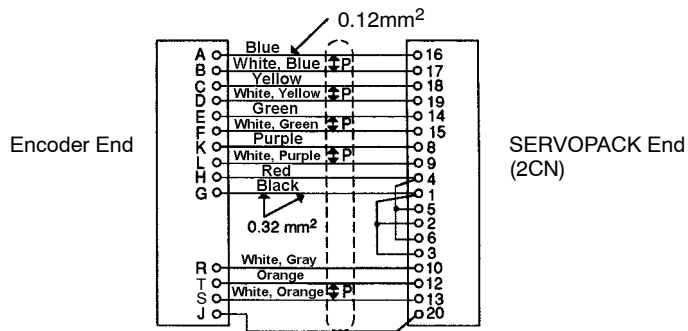

5

上正利有限公司
I P: twisted-pair shielded cables.

購買、維修 此手冊零組件

* Purchase caps, sockets, cases, and connectors separately. Refer to *Section 5.6.3 Connector* for details.

電話: 077-168888
Email: service@repairtw.com

Line id: @zzzz

www.repairtw.com

■ For the SGM and SGMP Types

Cables for Incremental Encoder (Connector Both Ends)

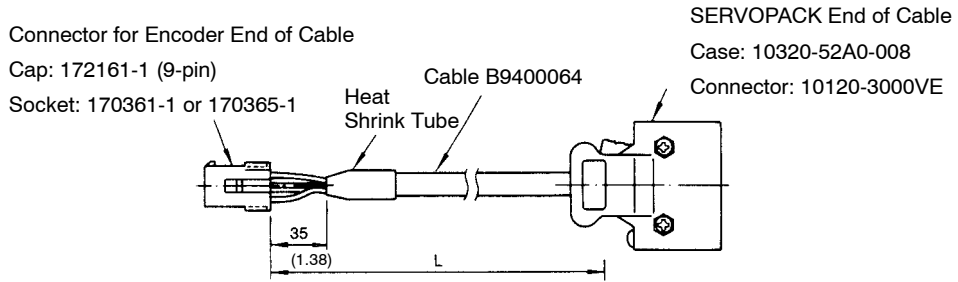

Type	L in mm (feet)	
DP9320089-1	3000 $\begin{smallmatrix} +100 \\ 0 \end{smallmatrix}$	(10 $\begin{smallmatrix} +0.33 \\ 0 \end{smallmatrix}$)
DP9320089-2	5000 $\begin{smallmatrix} +100 \\ 0 \end{smallmatrix}$	(16.7 $\begin{smallmatrix} +0.33 \\ 0 \end{smallmatrix}$)
DP9320089-3	10000 $\begin{smallmatrix} +500 \\ 0 \end{smallmatrix}$	(33.3 $\begin{smallmatrix} +1.67 \\ 0 \end{smallmatrix}$)
DP9320089-4	15000 $\begin{smallmatrix} +500 \\ 0 \end{smallmatrix}$	(50 $\begin{smallmatrix} +1.67 \\ 0 \end{smallmatrix}$)
DP9320089-5	20000 $\begin{smallmatrix} +500 \\ 0 \end{smallmatrix}$	(66.7 $\begin{smallmatrix} +1.67 \\ 0 \end{smallmatrix}$)

上正科技有限公司

Cables for Absolute Encoder (Connector Both Ends)

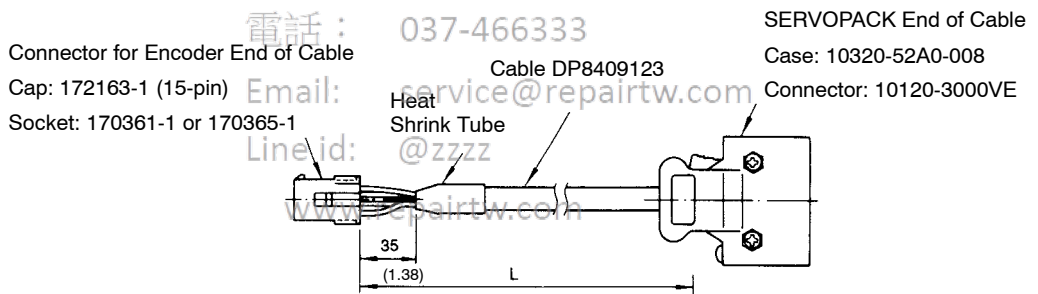

Type	L in mm (feet)	
DP9320088-1	3000 $\begin{smallmatrix} +100 \\ 0 \end{smallmatrix}$	(10 $\begin{smallmatrix} +0.33 \\ 0 \end{smallmatrix}$)
DP9320088-2	5000 $\begin{smallmatrix} +100 \\ 0 \end{smallmatrix}$	(16.7 $\begin{smallmatrix} +0.33 \\ 0 \end{smallmatrix}$)
DP9320088-3	10000 $\begin{smallmatrix} +500 \\ 0 \end{smallmatrix}$	(33.3 $\begin{smallmatrix} +1.67 \\ 0 \end{smallmatrix}$)
DP9320088-4	15000 $\begin{smallmatrix} +500 \\ 0 \end{smallmatrix}$	(50 $\begin{smallmatrix} +1.67 \\ 0 \end{smallmatrix}$)
DP9320088-5	20000 $\begin{smallmatrix} +500 \\ 0 \end{smallmatrix}$	(66.7 $\begin{smallmatrix} +1.67 \\ 0 \end{smallmatrix}$)

Cables for Incremental Encoder (SERVOPACK End without Connector)

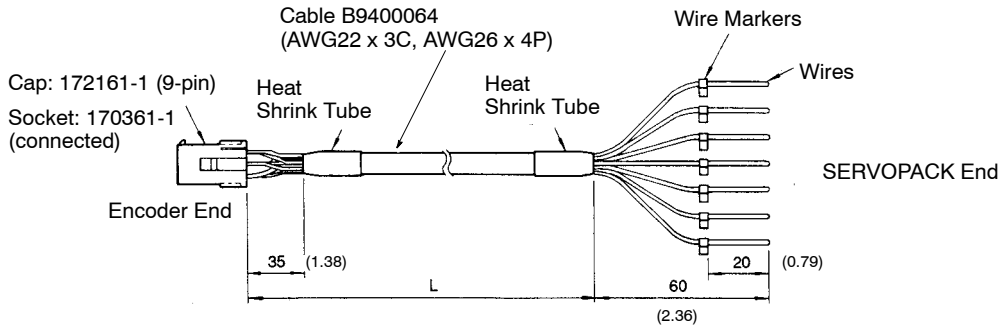

Type	L in mm (feet)
DP9320086-1	3000 $\begin{smallmatrix} + 100 \\ 0 \end{smallmatrix}$ (10 $\begin{smallmatrix} + 0.33 \\ 0 \end{smallmatrix}$)
DP9320086-2	5000 $\begin{smallmatrix} + 100 \\ 0 \end{smallmatrix}$ (16.7 $\begin{smallmatrix} + 0.33 \\ 0 \end{smallmatrix}$)
DP9320086-3	10000 $\begin{smallmatrix} + 500 \\ 0 \end{smallmatrix}$ (33.3 $\begin{smallmatrix} + 1.67 \\ 0 \end{smallmatrix}$)
DP9320086-4	15000 $\begin{smallmatrix} + 500 \\ 0 \end{smallmatrix}$ (50 $\begin{smallmatrix} + 1.67 \\ 0 \end{smallmatrix}$)
DP9320086-5	20000 $\begin{smallmatrix} + 500 \\ 0 \end{smallmatrix}$ (66.7 $\begin{smallmatrix} + 1.67 \\ 0 \end{smallmatrix}$)

5

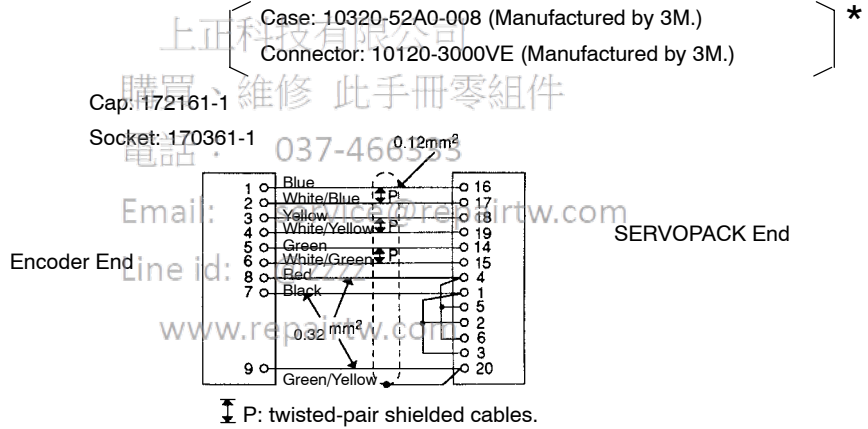

Cables for Absolute Encoder (SERVOPACK End without Connector)

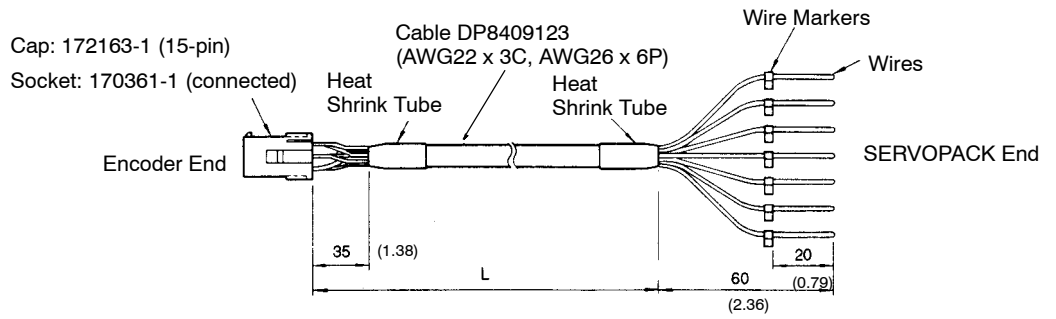

Type	L in mm (feet)	
DP9320085-1	3000 + 100 0	(10 + 0.33 0)
DP9320085-2	5000 + 100 0	(16.7 + 0.33 0)
DP9320085-3	10000 + 500 0	(33.3 + 1.67 0)
DP9320085-4	15000 + 500 0	(50 + 1.67 0)
DP9320085-5	20000 + 500 0	(66.7 + 1.67 0)

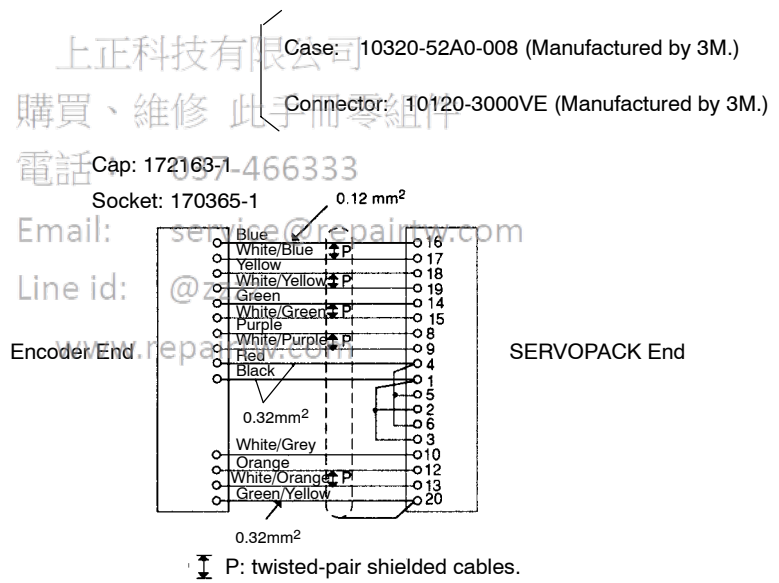

*

5

*Purchase cases and connectors separately. Refer to *Section 5.6.3 Connector* for details.

Cables for Incremental Encoder (Cable Only)

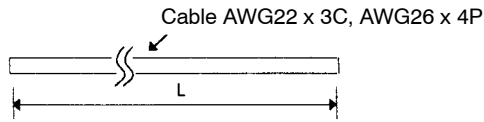

Type	L in mm (feet)
B9400064-1	3000 $\begin{smallmatrix} +100 \\ 0 \end{smallmatrix}$ (10 $\begin{smallmatrix} +0.33 \\ 0 \end{smallmatrix}$)
B9400064-2	5000 $\begin{smallmatrix} +100 \\ 0 \end{smallmatrix}$ (16.7 $\begin{smallmatrix} +0.33 \\ 0 \end{smallmatrix}$)
B9400064-3	10000 $\begin{smallmatrix} +500 \\ 0 \end{smallmatrix}$ (33.3 $\begin{smallmatrix} +1.67 \\ 0 \end{smallmatrix}$)
B9400064-4	15000 $\begin{smallmatrix} +500 \\ 0 \end{smallmatrix}$ (50 $\begin{smallmatrix} +1.67 \\ 0 \end{smallmatrix}$)
B9400064-5	20000 $\begin{smallmatrix} +500 \\ 0 \end{smallmatrix}$ (66.7 $\begin{smallmatrix} +1.67 \\ 0 \end{smallmatrix}$)

Cap: 172161-1 (Manufactured by AMP.)
 Socket: 170361-1 or 170365-1 (Manufactured by AMP.)

Case: 10320-52A0-008 (Manufactured by 3M.)
 Connector: 10120-3000VE (Manufactured by 3M.)

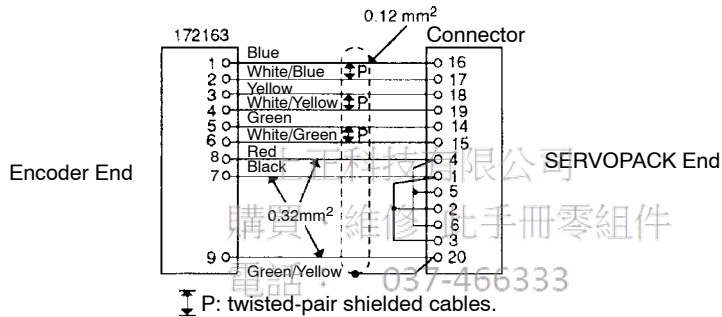

* Purchase caps, sockets, cases, and connectors separately. Refer to Section 5.6.3 Connector for details.

Line id: @zzzz

www.repairtw.com

Cables for Absolute Encoder (Cable Only)

Cable AWG22 x 3C, AWG26 x 6P

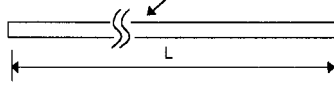

Type	L in mm (feet)
DP8409123-1	3000 $\begin{smallmatrix} + 100 \\ 0 \end{smallmatrix}$ (10 $\begin{smallmatrix} + 0.33 \\ 0 \end{smallmatrix}$)
DP8409123-2	5000 $\begin{smallmatrix} + 100 \\ 0 \end{smallmatrix}$ (16.7 $\begin{smallmatrix} + 0.33 \\ 0 \end{smallmatrix}$)
DP8409123-3	10000 $\begin{smallmatrix} + 500 \\ 0 \end{smallmatrix}$ (33.3 $\begin{smallmatrix} + 1.67 \\ 0 \end{smallmatrix}$)
DP8409123-4	15000 $\begin{smallmatrix} + 500 \\ 0 \end{smallmatrix}$ (50 $\begin{smallmatrix} + 1.67 \\ 0 \end{smallmatrix}$)
DP8409123-5	20000 $\begin{smallmatrix} + 500 \\ 0 \end{smallmatrix}$ (66.7 $\begin{smallmatrix} + 1.67 \\ 0 \end{smallmatrix}$)

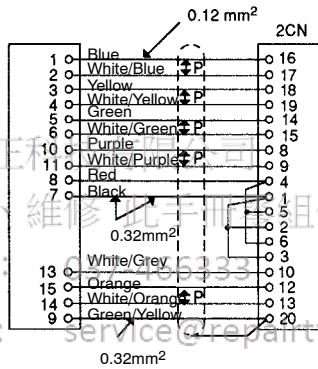
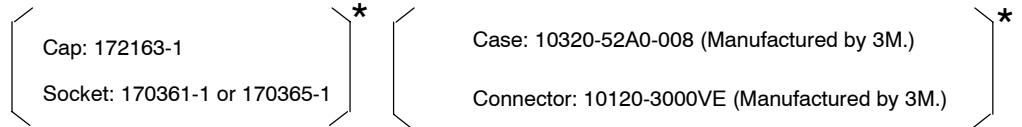

上正和...
 購買、維修零件
 電話: 02-26513333
 Email: service@repairtw.com
 Line id: @tw555
 www.repairtw.com

* Purchase plug, cable clamp, cases, and connectors separately. Refer to *Section 5.6.3 Connector* for details.

■ Appropriate Cables

Details of the encoder cables are summarized in the table below. These cables are not supplied as accessories with a SERVOPACK or servomotor. Purchase in standard specified lengths as required.

5.6.6 Battery for Absolute Encoder

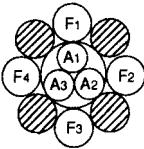
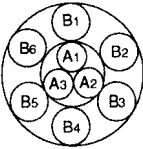
Cable Specification	Incremental Encoder (Yaskawa Drg. #B9400064)	Absolute Encoder (Yaskawa Drg. #DP8409123)
Basic Specifications	Compound KQVV-SW AWG22 x 3C, AWG26 x 4P	Compound KQVV-SW AWG22 x 3C, AWG26 x 6P
Finished Dimension	ø7.5 mm (ø0.30)	ø8.0 mm (ø0.31)
Internal Structure and Lead Colors	 A ₁ Red A ₂ Black A ₃ Green/Yellow F ₁ Blue - White/Blue (Twisted pair) F ₂ Yellow - White/Yellow (Twisted Pair) F ₃ Green - White/Green (Twisted Pair) F ₄ Orange - White/Orange (Twisted Pair)	 A ₁ Red A ₂ Black A ₃ Green/Yellow B ₁ Blue - White/Blue (Twisted pair) B ₂ Yellow - White/Yellow (Twisted Pair) B ₃ Green - White/Green (Twisted Pair) B ₄ Orange - White/Orange (Twisted Pair) B ₅ Purple - White/Purple (Twisted Pair) B ₆ Grey - White/Grey (Twisted Pair)
Yaskawa standard specifications	Standard lengths: 3 m (9.8) , 5 m (16.4) , 10 m (32.8), 15 m (49.2), 20 m (65.6) *	

5

*When appropriate cable is used, the allowable wiring distance between SERVOPACK and servomotor (PG) is 20 m (65.6) max.

Note See items 469 to 472 and 473 to 477 in this section for details about cables with connectors.

Email: service@repairtw.com

Line id: @zzzz

5.6.6 Battery for Absolute Encoder

Purchase the following battery if using an absolute encoder. (Manufactured by Toshiba Battery Co., Ltd.)

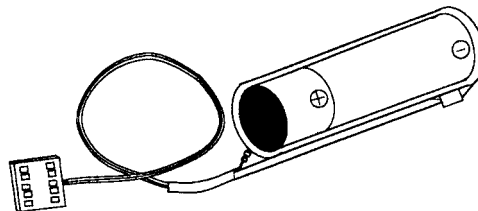

- Lithium Battery: ER 6 V C3
- Nominal Voltage: 3.6 V
- Standard Capacity: 2000 mAh

5.6.7 1CN Connector

This connector is required to connect the host controller to 1CN on the SERVOPACK.

- Connector

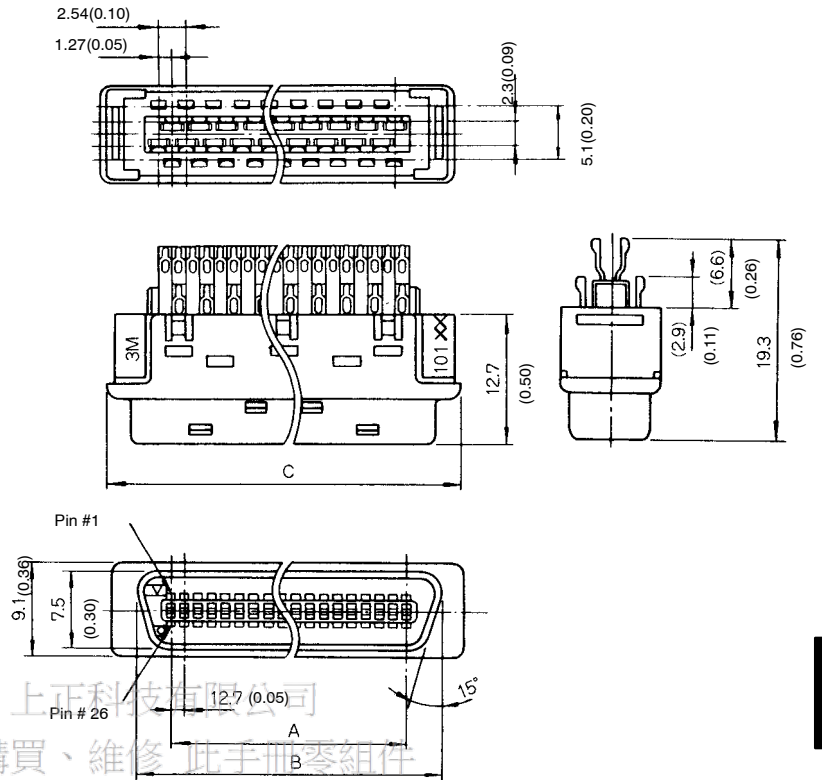

上正科技有限公司
購買、維修此手冊零組件

電話： 037-466333

Email: service@repairtw.com

Line id: @zzzz

Units: mm (inches)

Connector Type	A	B	C
10150-3000VE	30.48 (1.20)	36.7 (1.44)	41.1 (1.62)

Manufactured by 3M.

- Case

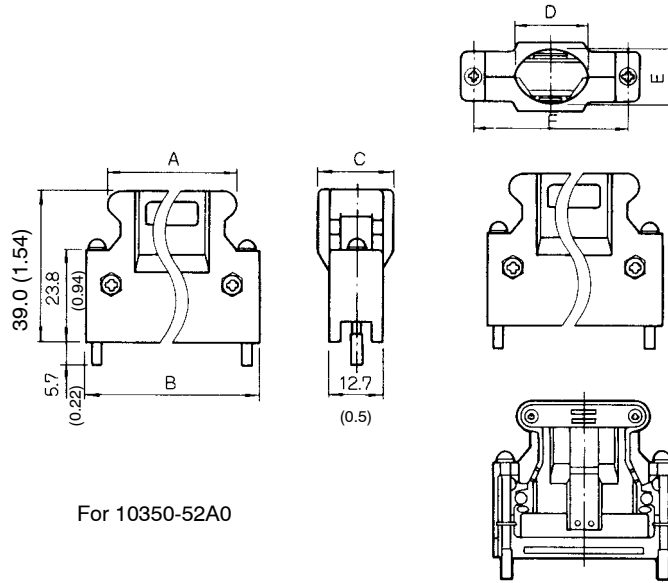

For 10350-52A0

Diagram of Assembled Connector (for reference)

Units: mm (inches)

Connector Type	Case Type	A	B	C	D	E	F
10150-3000 VE	10350-5 2A0-008	41.1 (1.62)	52.4 (2.06)	18.0 (0.71)	17.0 (0.67)	14.0 (0.55)	46.5 (1.83)

山王科技有限公司
購買、維修、此手冊零件

電話： 037-466333

Manufactured by 3M.

Email: service@repairtw.com

The 1CN connector type is shown below.

Connector Type	Application	Connector Part List			
		Connector		Case	
		Type	Qty	Type	Qty
DE9406970	I/O connector for 1CN	10150-3000V E*	1	10350-52A0-008*	1

* Manufactured by 3M.

5.6.8 Connector Terminal Block Converter Unit

A connector terminal block converter unit comprises a 1CN connector and 0.5 m (1.64 ft) cable.

The terminal block terminal numbers match the SERVOPACK 1CN connector pin numbers.

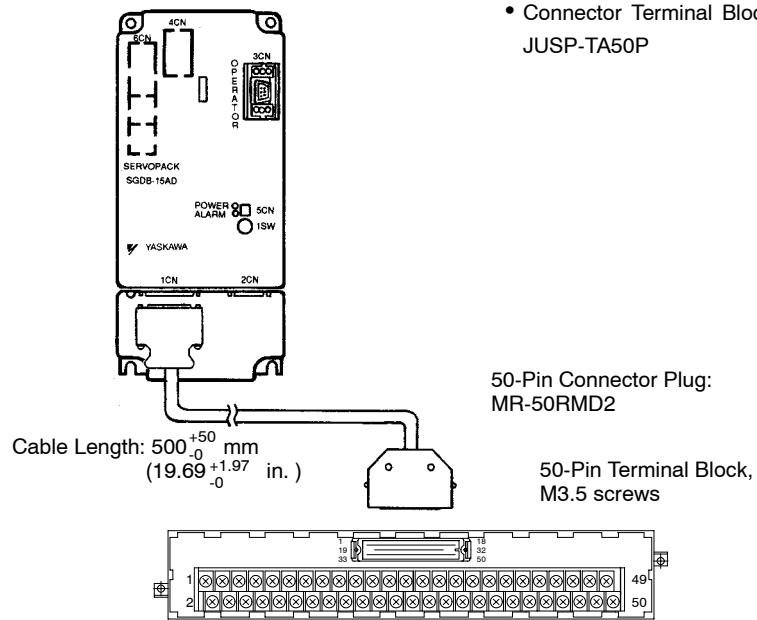

上正科技有限公司

購買、維修 此手冊零組件

電話： 037-466333

Email: service@repairtw.com

Line id: @zzzz

www.repairtw.com

SERVO SELECTION AND DATA SHEETS

5.6.8 Connector[Terminal]Block[Converter]Unit cont.

The relationships between terminal block pin numbers and signal names are shown in the table below.

SGDB SERVOPACK			Terminal block unit		
Signal Name	1CN Pin No.		Connector No.		Terminal No.
SG	1		A1		1
SG	2		B1		2
PL1	3		A2		3
SEN	4		B2		4
V-REF	5		A3		5
SG	6		B3		6
PULS	7		A4		7
/PULS	8		B4		8
T-REF	9		A5		9
SG	10		B5		10
SIGN	11		A6		11
/SIGN	12		B6		12
PL2	13		A7		13
/CLR	14		B7		14
CLR	15		A8		15
TQR-M	16		B8		16
VTG-M	17		A9		17
PL3	18		B9		18
PCO	19		A10		19
/PCO	20		B10		20
BAT+	21		A11		21
BAT-	22		B11		22
+12 V	23		A12		23
-12 V	24		B12		24
/V-CMP+	25		A13		25
/V-CMP-	26		B13		26
/TGON+	27		A14		27
/TGON-	28		B14		28
/S-RDY+	29		A15		29
/S-RDY-	30		B15		30
ALM+	31		A16		31
ALM-	32		B16		32
PAO	33		A17		33
/PAO	34		B17		34
PBO	35		A18		35
/PBO	36		B18		36
ALO1	37		A19		37
ALO2	38		B19		38
ALO3	39		A20		39
/S-ON	40		B20		40
/P-CON	41		A21		41
P-OT	42		B21		42
N-OT	43		A22		43
/ALM-RST	44		B22		44
/P-CL	45		A23		45
/N-CL	46		B23		46
+24 V IN	47		A24		47
PSO	48		B24		48
/PSO	49		A25		49
FG	50		B25		50

Connector Case	Cable: Supplied with terminal block
	⇕P : Twisted pair

5.6.9 Cable With 1CN Connector and One End Without Connector

Use a cable with no connector at the host controller end. The loose wires are marked with labels with terminal numbers indicated.

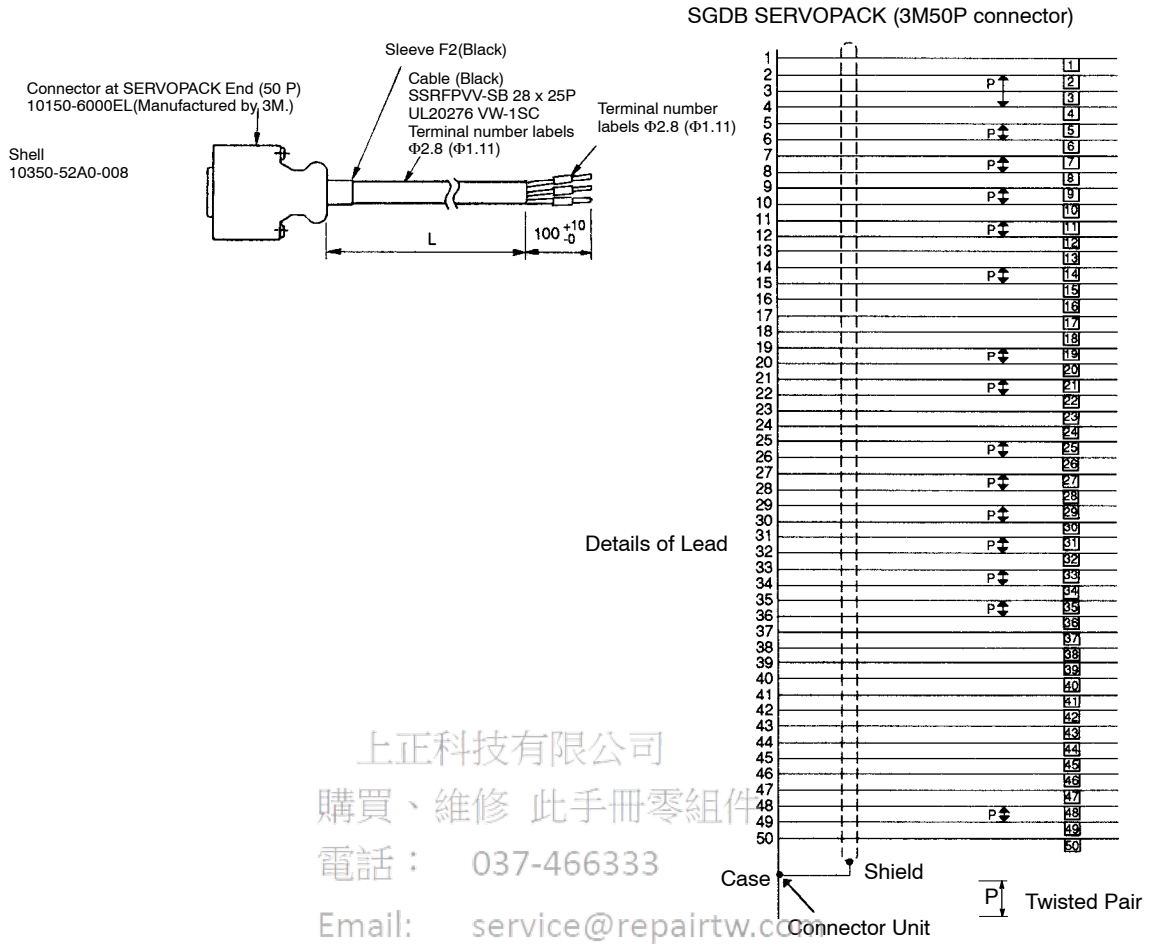

上正科技有限公司
購買、維修 此手冊零組件
電話： 037-466333
Email: service@repairtw.com
Line id: @zzzz

5

Type	www.repairtw.com		L in mm (feet)	
DE9406969-1	1000	⁺³⁰ ₀	3.33	^{+0.1} ₀
DE9406969-2	2000	⁺⁵⁰ ₀	6.67	^{+0.17} ₀
DE9406969-3	3000	⁺⁵⁰ ₀	10	^{+0.17} ₀

5.6.10 Circuit Breaker

The customer should purchase a circuit breaker (MCCB) of appropriate capacity.

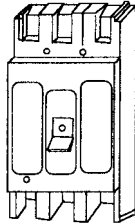

- Recommended Product

Ground fault detector for motor protection manufactured by Mitsubishi Electric Co. Ltd.
Type: MN50-CF

Use to protect the power lines.

5.6.11 Noise Filter

Select the noise filter from the following three types according to the SERVOPACK capacity.

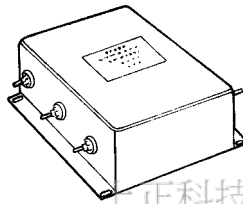

Install to eliminate external noise from the power lines.

5

- Dimensional Diagrams

- LF-300 (Three-phase 200 VAC Class)

工正科技有限公司
購買、維修 此手冊零組件
電話： 037-466333
Email: service@repairtw.com
Line id: @zzzz

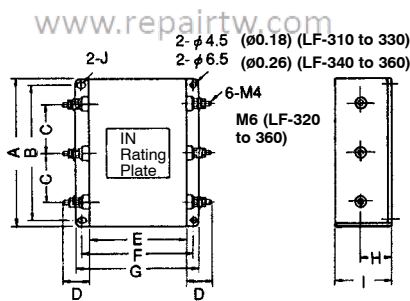

in mm (inches)

Parts Name	A	B	C	D	E	F	G	H	I	J
LF-310	180 (7.09)	170 (6.69)	60 (2.36)	25 (0.98)	120 (4.72)	135 (5.31)	150 (5.91)	35 (1.38)	65 (2.56)	4.5(0.18) ×7
LF-315	180 (7.09)	170 (6.69)	60 (2.36)	25 (0.98)	120 (4.72)	135 (5.31)	150 (5.91)	35 (1.38)	65 (2.56)	4.5(0.18) ×7
LF-320	180 (7.09)	170 (6.69)	60 (2.36)	29 (1.14)	120 (4.72)	135 (5.31)	150 (5.91)	35 (1.38)	65 (2.56)	4.5(0.18) ×7
LF-330	180 (7.09)	170 (6.69)	60 (2.36)	29 (1.14)	120 (4.72)	135 (5.31)	150 (5.91)	35 (1.38)	65 (2.56)	4.5(0.18) ×7
LF-340	180 (7.09)	160 (6.30)	50 (1.97)	30 (1.18)	200 (7.87)	220 (8.66)	240 (9.45)	40 (1.57)	80 (3.15)	6.5(0.26) ×9
LF-350	180 (7.09)	160 (6.30)	50 (1.97)	30 (1.18)	200 (7.87)	220 (8.66)	240 (9.45)	40 (1.57)	80 (3.15)	6.5(0.26) ×9
LF-360	200 (7.87)	180 (7.09)	60 (2.36)	30 (1.18)	300 (11.81)	320 (12.60)	340 (13.39)	40 (1.57)	100 (3.93)	6.5(0.26) ×9

- LF-K (Three-phase 200 VAC Class)

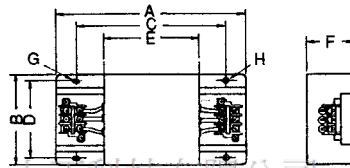

上正科技有限公司

購買、維修 此手冊零組件

電話： 037-466333

in mm (inches)

Parts Name	Terminal Block	A	B	C	D	E	F	G	H
LF-380K	TE-K22 M6	670 (26.38)	400 (15.75)	560 (22.05)	380 (14.96)	500 (19.69)	170 (6.69)	9×Ø6.5 (0.26)	Ø6.5 (0.26)

www.repairtw.com

- FN258-100 (Three-phase 200 VAC Class)

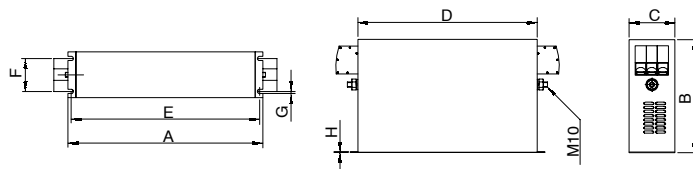

in mm (inches)

Parts Name	A	B	C	D	E	F	G	H
FN-258-100	379±1.5 (14.92±0.06)	220 (8.66)	90±8 (3.54±0.31)	350±1.2 (13.78±0.05)	364 (14.33)	65 (2.56)	6.5 (0.26)	1.5 (0.06)

5

5.6.12 Magnetic Contactor

A magnetic connector turns ON and OFF the servo. Be sure to attach a surge suppressor to the excitation coil of the magnetic contactor.

Select a magnetic contactor based on the current capacity of the SERVOPACK. For multiple servo systems, select a contactor based on total current capacity.

Following table shows external dimensions and terminal symbols for the magnetic contactor.

Model	External Dimensions [mm (in)]	Mounting Hole Dimensions [mm (in)]	Terminal Symbols
HI-11J HI-14J	<p>Approx. mass: 0.25 kg (0.551 lb)</p>		<p>Auxiliary NO contact</p> <p>a A1 A2 b</p> <p>R 1 S 3 T 5 1 13</p> <p>U 2 V 4 W 6 2 14</p> <p>Auxiliary NC contact</p> <p>a A1 A2 b</p> <p>R 1 S 3 T 5 1 11</p> <p>U 2 V 4 W 6 2 12</p>
HI-15J HI-18J	<p>Approx. mass: 0.38 kg (0.838 lb)</p>		<p>Auxiliary NO contact/ Auxiliary NC contact</p> <p>a A1 A2 b</p> <p>R 1 S 3 T 5 1 21 3 13</p> <p>U 2 V 4 W 6 2 22 4 12</p>
HI-20J	<p>Approx. mass: 0.38 kg (0.838 lb)</p>		<p>Auxiliary NO contact/ Auxiliary NC contact</p> <p>a A1 A2 b</p> <p>R 1 S 3 T 5 5 41 7 23</p> <p>U 2 V 4 W 6 6 42 8 24</p>

5

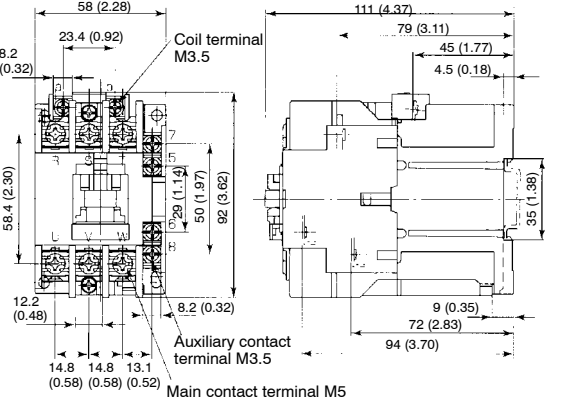
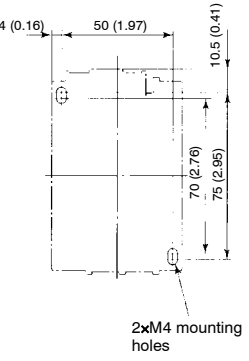
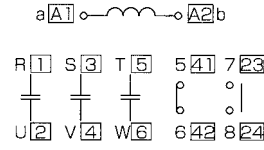
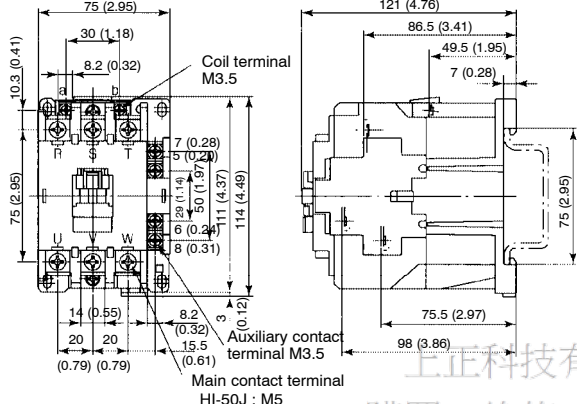
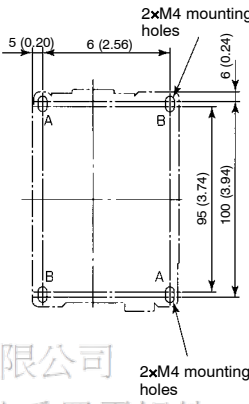
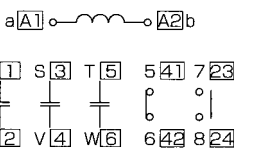
Model	External Dimensions [mm (in)]	Mounting Hole Dimensions [mm (in)]	Terminal Symbols
HI-25J HI-35J	 <p>Coil terminal M3.5</p> <p>Auxiliary contact terminal M3.5</p> <p>Main contact terminal M5</p> <p>Approx. mass: 0.68 kg (1.499 lb)</p>	 <p>2xM4 mounting holes</p>	<p>Auxiliary NO contact/ Auxiliary NC contact</p> 
HI-50J HI-65J	 <p>Coil terminal M3.5</p> <p>Auxiliary contact terminal M3.5</p> <p>Main contact terminal HI-50J: M5 HI-65J: M6</p> <p>Approx. mass: 1.1 kg (2.425 lb)</p>	 <p>2xM4 mounting holes</p>	<p>Auxiliary NO contact/ Auxiliary NC contact</p> 

* The magnetic contactor is manufactured by Yaskawa Controls.

電話： 037-466333

Email: service@repairtw.com

Line id: @zzzz

www.repairtw.com

5.6.13 Surge Suppressor

Attach a surge suppressor to the magnetic contactor to prevent power supply noise and protect contacts.

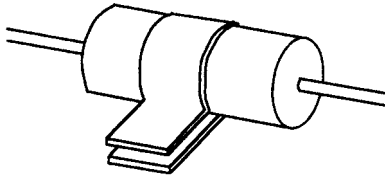

• Recommended Product

- Spark Killer manufactured by Okaya Electric Industries Co., Ltd.
- Type: CR50500BA (250 VAC)
- Capacitance: 0.5 μ F \pm 20%
- Resistance: 50 Ω (1/2 W) \pm 30%

5.6.14 Regenerative Resistor Unit

For SERVOPACKs (SGDB-60 or higher) for use with motors with 5.5 kW or more, externally attach a regenerative resistor to the SERVOPACK. This resistor is used for dissipating regenerative energy.

Use one of the following regenerative resistor units according to the SERVOPACK type:

SGDB SERVOPACK Type	Regenerative Resistor Unit Type
60AD□	JUSP-RA04
75ADG	JUSP-RA05
1AADG	
1EADG	

• Dimensional Drawings

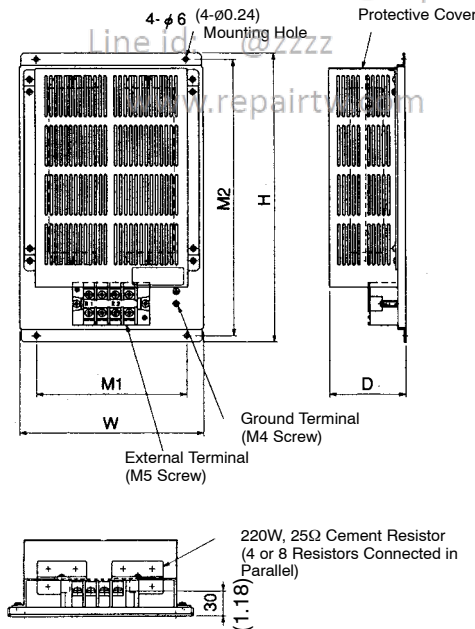

上正科技有限公司
 購買、維修 此手冊零組件
 電話： 037-466333

Email: service@repairtw.com

Line id: @7zzz
www.repairtw.com

■ Terminal Numbers

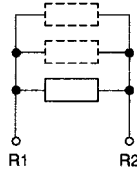

Units: mm (inches)

Type	W	H	D	M1	M2	Approx. mass
JUSP-RA04	220 (8.66)	350 (13.78)	92 (3.62)	180 (7.09)	335 (13.19)	4kg
JUSP-RA05	300 (11.81)	350 (13.78)	95 (3.74)	250 (9.84)	335 (13.19)	7kg

5.6.15 Variable Resistor for Speed Setting

This variable resistor is used to give speed references by applying the speed reference voltage from an external power supply across 1CN pins #5 and #6.

■ Dimensional Drawings

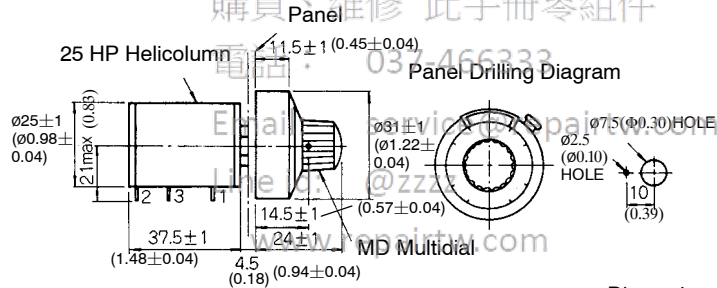

■ Connection to External Power Supply

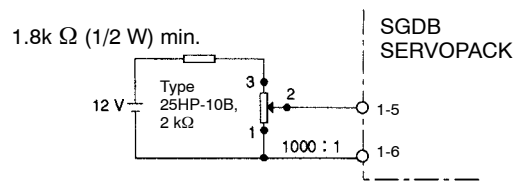

Type 25HP-10B

Multi-wrap variable resistor with MD10-30B4 dial, manufactured by Sakae Tsushin Kogyo K.K.

5.6.16 Encoder Signal Converter Unit

Unit to convert the encoder signal output from the line driver to an open collector output or voltage pulse output.

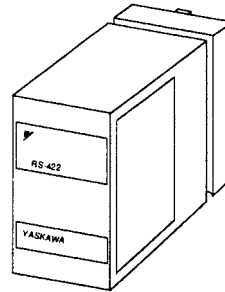

Line Receiver Unit

■ Terminal Numbers

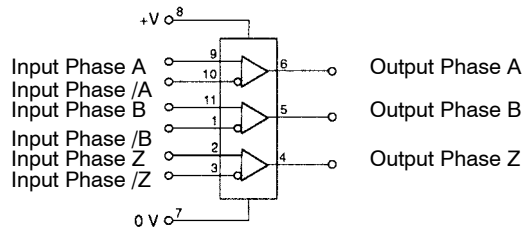

上正科技有限公司

■ Dimensional Drawings

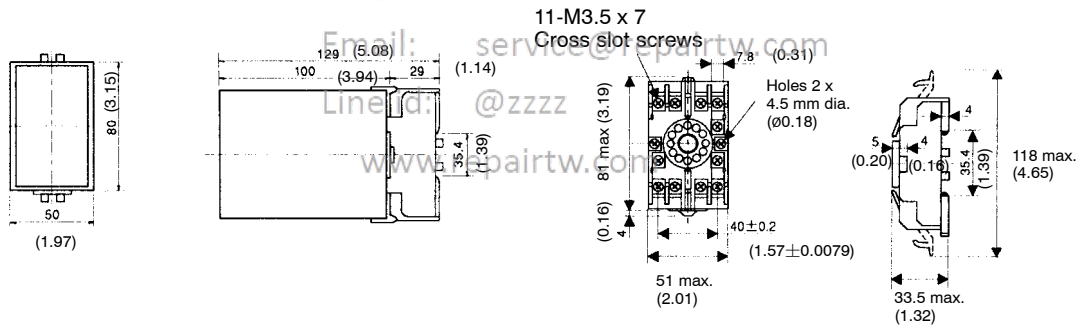

Units: mm (inches)

■ Specifications

The encoder signal converter unit specifications are as follows:

Type	Receiver Unit			
	LRX-01/A1	LRX-01/A2	LRX-01/A3	LRX-01/A4
Power Supply	12 VDC \pm 10%, 100 mA		5 VDC \pm 5%, 100 mA	
Input Signals	Balanced line driver input (RS-422)			
Output Signals	Voltage pulse output	Open collector output	Voltage pulse output	Open collector output
Input Signal Level	Voltage differential \geq 0.3 V, internal termination resistance 100 Ω			
Output Signal Level	H: 10 V min. (1 mA) L: 0.5 V max. (30 mA)	L: 0.5 V max. (30 mA) Withstand voltage: 50 V	H: 3 V min. (1 mA) L: 0.5 V max. (30 mA)	L: 0.5 V max. (30 mA) Withstand voltage: 50 V
Operating Ambient Temperature Range	0 to +60°C			
IC Used	AM26LS32C Receiver IC, or equivalent			

上正科技有限公司

購買、維修 此手冊零組件

電話： 037-466333

Email: service@repairtw.com

Line id: @zzzz

www.repairtw.com

5.6.17 Cables for Connecting PC and SERVOPACK

Special cables for connecting a PC to a SERVOPACK. Using these cables allows monitoring and setting of parameters with a PC.

PC software is available for these communications. Ask your Yaskawa representative for details. Operate the software as described in the manual supplied.

■ Connection Diagram

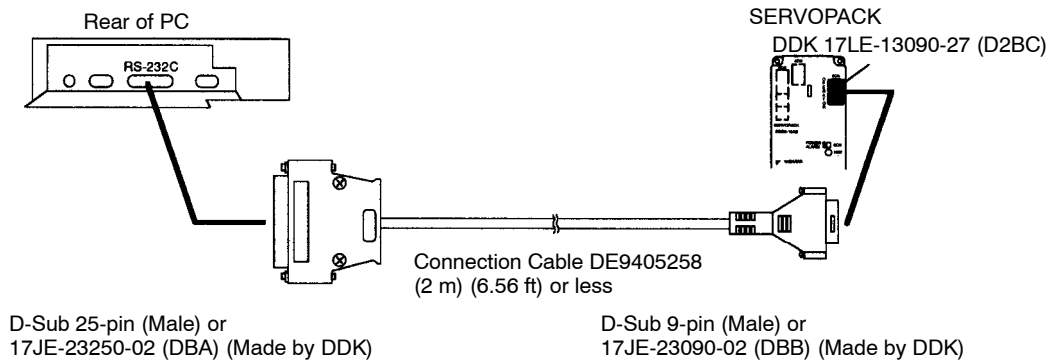

■ Dimensional Drawings for Type DE9405258 (for NEC PC)

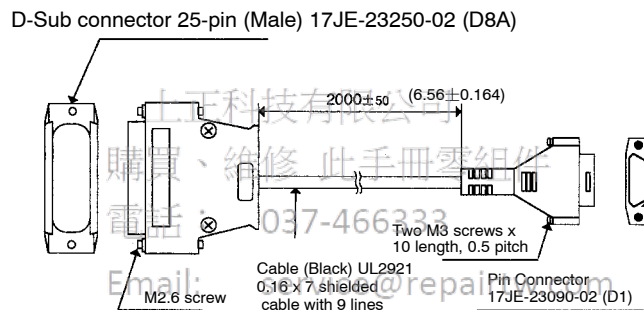

Note: Fold the cable shielding back at each end of the cable and secure it with clamps.

■ Communications Specifications

- Baud Rate: 9600 bps
- Number of Bits
 - Start: 1 bit
 - Data: 7 bits
 - Stop: 1 bit
 - Parity: 1 bit (even)
- Synchronization Start-Stop
- XON/XOFF Control None

- Shift Control: None
- Communications Method: Semi-duplex

■ Connecting-circuit Specifications

Using the RS232C Port

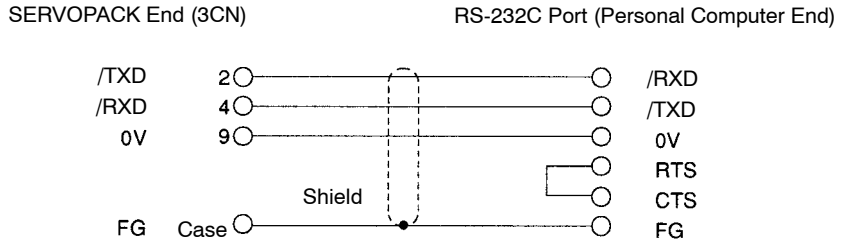

Note: Maximum cable length is 2 m (6.56 ft).

Using the RS422A Port

Connection is also possible to the RS-422A port. In this case, the connection circuit is as follows:

- Transmission Distance: 30 m (98.4 ft) max.
- Transmission System: RS-422A

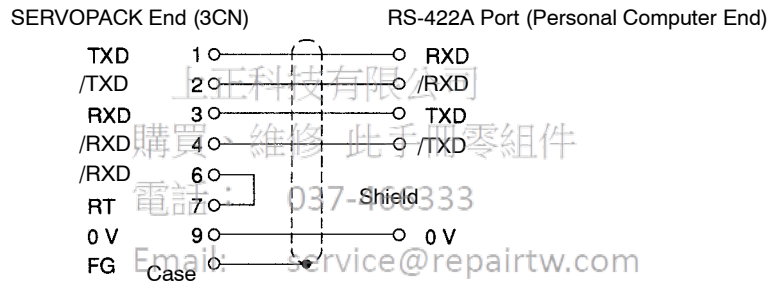

Terminal Arrangement at SERVOPACK End

Pin #	Signal Name	Signal Circuit Name	Signal Direction
1	TXD	Transmit data (not inverted)	P←S
2	/TXD	Transmit data (inverted)	P←S
3	RXD	Receive data (not inverted)	P→S
4	/RXD	Receive data (inverted)	P→S
5	OPH		#
6	/RXD	Shorting pins 6 and 7 inserts 220 Ω termination resistance between RXD and /RXD.	
7	RT		
8	5VPP		#
9	GND	Signal ground 0 V	

P: Personal computer
 S: SERVOPACK
 #: Terminal not used, leave open.

■ Cable for Connecting SERVOPACK and IBM PC (IBM Compatible PC)

Use Yaskawa DE9408565 type cable.

- Dimensional Drawings: Type DE9408565

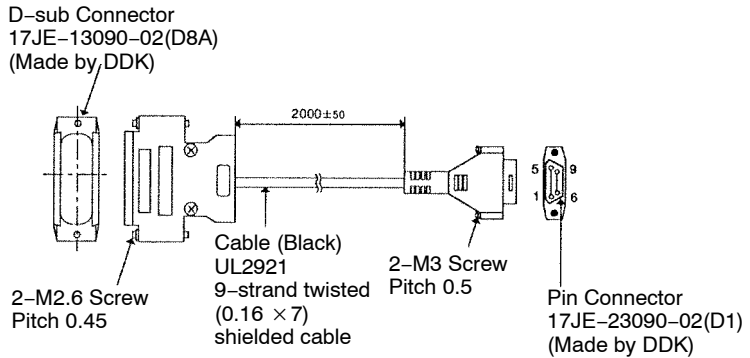

Note: Fold back the cable shielding at each end of the cable and secure it with clamp.

- Connection

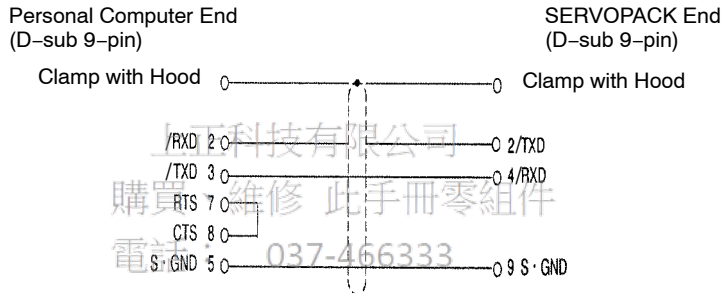

上海科技有限公司
購買、維修 此手冊零組件
電話: 037-466333

Email: service@repairtw.com

Line id: @zzzz

www.repairtw.com

■ Cable for connecting SERVOPACK and NEC PC-98 half-pitch connector

Use Yaskawa DE9408564 type cable.

• Dimensional Drawings: Type DE9408564

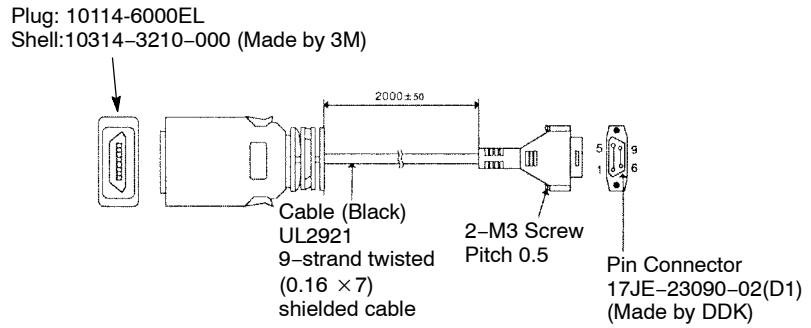

Note: Fold back the cable shielding at each end of the cable and secure it with clamp.

• Connection

Personal Computer End

SERVOPACK End
(D-sub 9-pin)

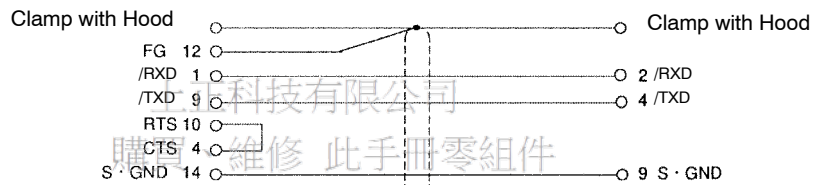

電話： 037-466333

Email: service@repairtw.com

Line id: @zzzz

www.repairtw.com

INSPECTION, MAINTENANCE, AND TROUBLESHOOTING

6

This chapter describes the basic inspections and maintenance to be carried out by the customer.

In addition, troubleshooting procedures are described for problems which cause an alarm display and for problems which result in no alarm display.

6.1	Inspection and Maintenance	500
6.1.1	Servomotor	500
6.1.2	SERVOPACK	501
6.1.3	Replacing Battery for Absolute Encoder	502
6.2	Troubleshooting	503
6.2.1	Troubleshooting Problems with Alarm Display	503
6.2.2	Troubleshooting Problems With No Alarm Display	529
6.2.3	Internal Connection Diagram and Instrument Connection Examples	531

Line id: @zzzz

www.repairtw.com

6.1 Inspection and Maintenance

This section describes the basic inspections and maintenance for Σ -Series servo drives.

6.1.1 Servomotor

For inspection and maintenance of servomotors, follow the simple, daily inspection procedures in the table below.

The AC servomotors are brushless. Simple, daily inspection is sufficient. The inspection and maintenance frequencies in the table are only guidelines. Increase or decrease the frequency to suit the operating conditions and environment.

Item	Frequency	Procedure	Comments
Vibration and noise	Daily	Touch and listen.	Levels higher than normal?
Appearance	According to degree of contamination	Clean with cloth or compressed air.	
Insulation resistance measurement	At least once a year	Disconnect SERVOPACK and test insulation resistance at 500 V. Must exceed 10 M Ω . (See note below)	Contact your Yaskawa representative if the insulation resistance is below 10 M Ω .
Replace oil seal	At least once every 5,000 hours	Remove servomotor from machine and replace oil seal.	Applies only to motors with oil seal.
Overhaul	At least once every 20,000 hours or 5 years	Contact your Yaskawa representative. service@repairtw.com	The customer should not disassemble and clean the servomotor.

Line id: @zzzz

Note Measure across the servomotor FG and the phase-U, phase-V, or phase-W power lead.

During inspection and maintenance, do not disassemble the servomotor. If disassembly of the servomotor is required, contact your Yaskawa representative.

6.1.2 SERVOPACK

For inspection and maintenance of the SERVOPACK, follow the inspection procedures in the table below at least once every year.

The SERVOPACK contains highly reliable parts and daily inspection is not required. Carry out the inspections and maintenance in the table below once every year.

Item	Frequency	Procedure	Remedy
Clean unit interior and circuit boards	At least once a year	Check for dust, dirt, and oil on the surfaces.	Clean with compressed air.
Loose screws	At least once a year	Check for loose terminal block and connector screws.	Tighten any loose screws.
Defective parts in unit or on circuit boards.	At least once a year	Check for discoloration, damage or discontinuities due to heating.	Contact your Yaskawa representative.

Part Replacement Schedule

The following parts are subject to mechanical wear or deterioration over time. To avoid failure, replace these parts at the frequency indicated.

Part	Standard Replacement Period	Replacement Method
Cooling fan	4 to 5 years	Replace with new part.
Smoothing Capacitor	7 to 8 years	Test. Replace with new part if necessary.
Relays		Test. Replace if necessary.
Fuse	10 years	Replace with new part.
Aluminum Electrolytic Capacitor on Circuit Board	5 years	Test. Replace with new circuit board if necessary.

Note Operating Conditions:

- Ambient Temperature: annual average 30°C
- Load Factor: 80% max.
- Operation Rate: 20 hours/day max.

If the SERVOPACK has been already overhauled at YASKAWA, its parameters are set back to the standard settings on shipment. Always check the parameters before operating the motor.

6.1.3 Replacing Battery for Absolute Encoder

Battery replacement is only required for servo systems using an absolute encoder.

Install the battery type recommended below (purchased by the customer) in the host controller to allow the absolute encoder to store position data when the power is turned OFF.

Recommended Battery:

- Lithium Battery
ER 6 V C3, manufactured by Toshiba Battery Co., Ltd. 3.6 V, 2000 mAh
Estimated Life: Approximately 10 years

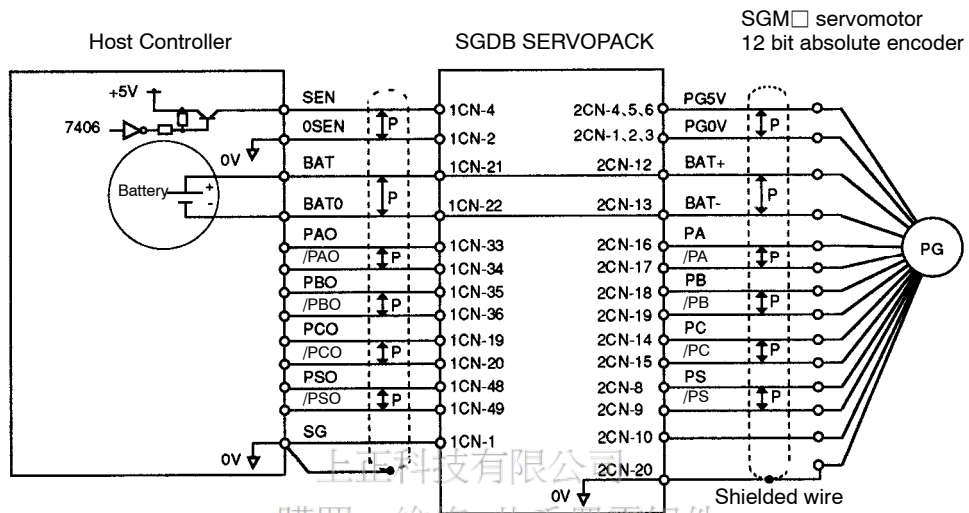
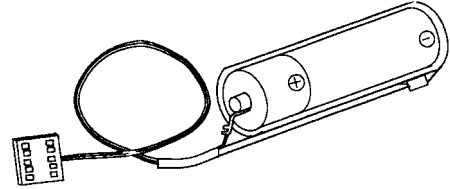

Note PS, PSO signals are used only for 12 bit absolute encoder.

The battery voltage is not internally monitored in the SERVOPACK. Therefore, detect low battery voltage at the host controller.

Minimum required battery voltage is 2.8 V.

Replace the battery according to the following procedure if the battery voltage drops to the minimum required battery voltage. The battery maintains absolute position data stored in the encoder.

Battery Replacement Procedure:

- 1) Turn ON the SERVOPACK and wait at least 3 minutes. The absolute encoder capacitors are charged.
- 2) Replace the battery in the host controller. The SERVOPACK power supply can be ON or OFF during battery replacement.

Note After completing step 1 above, the absolute encoder will function normally for up to 2 days with no battery.

6.2 Troubleshooting

This section describes causes and remedies for problems which cause an alarm display and for problems which result in no alarm display.

6.2.1 Troubleshooting Problems with Alarm Display

Refer to the tables below to identify the cause of a problem which causes an alarm display and take the remedy described.

Note that A.99 does not indicate an alarm.

Contact your Yaskawa representative if the problem cannot be solved by the described procedures.

上正科技有限公司

購買、維修 此手冊零組件

電話： 037-466333

Email: service@repairtw.com

Line id: @zzzz

www.repairtw.com

■ A.00

Display and Outputs

Digital Operator Display and Alarm Name	Alarm Output			
	Alarm Code Output			Alarm Output
	ALO1	ALO2	ALO3	
A.00 Absolute data error	OFF	OFF	OFF	OFF

OFF: Output transistor is OFF
ON: Output transistor is ON

Status When Alarm Occurred

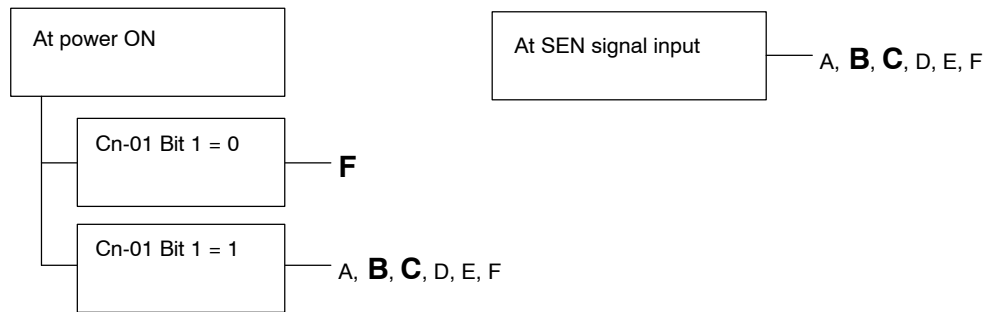

	Cause	Remedy
A	Absolute encoder power not supplied from SERVOPACK.	Use the SERVOPACK power supply for the absolute encoder.
B	Incorrect absolute encoder wiring (PA, PB, RESET, SEN signal etc.)	Check and correct the absolute encoder wiring.
C	Absolute encoder malfunctioned	<ul style="list-style-type: none"> If Cn-01 Bit 1 = 0, turn SEN signal OFF and back ON. If Cn-01 Bit 1 = 1, turn SERVOPACK power OFF and back ON.
D	Incorrect parameter setting. Incremental encoder used with Cn-01 Bit E set to 1.	Set Cn-01 Bit E to 0.
E	Absolute encoder defective	Replace servomotor.
F	Circuit board (1PWB) defective	Replace SERVOPACK.

Note Alarm A.00 is reset when the power is turned OFF and back ON. It is not reset by the normal alarm reset.

NOTE Resetting SEN Signal

When resetting the SEN signal (i.e., turning it OFF and then back ON) for any reason, keep the SEN signal at the high level for more than 1.3 s before turning it OFF.

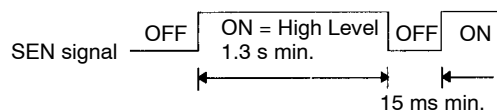

■ A.02

Display and Outputs

Digital Operator Display and Alarm Name	Alarm Output			
	Alarm Code Output			Alarm Output
	ALO1	ALO2	ALO3	
A.02 Parameters breakdown	OFF	OFF	OFF	OFF

OFF: Output transistor is OFF

ON: Output transistor is ON

Status When Alarm Occurred



	Cause	Remedy
A	Power turned OFF during parameter write. Alarm occurred next power ON.	Replace SERVOPACK.
B	Circuit board (1PWB) defective	Replace SERVOPACK.

上正科技有限公司

■ A.04

購買、維修 此手冊零組件

電話： 037-466333

Display and Outputs

Email: service@repairtw.com

Digital Operator Display and Alarm Name	Alarm Output			
	Alarm Code Output			Alarm Output
	ALO1	ALO2	ALO3	
A.04 Parameter setting error	OFF	OFF	OFF	OFF

OFF: Output transistor is OFF

ON: Output transistor is ON

Status When Alarm Occurred



	Cause	Remedy
A	An out-of-range parameter was previously set or loaded.	Reset all parameters in range. Otherwise, re-load correct parameters.
B	Circuit board (1PWB) defective	Replace SERVOPACK.

■ A.10

Display and Outputs

Digital Operator Display and Alarm Name	Alarm Output			
	Alarm Code Output			Alarm Output
	ALO1	ALO2	ALO3	
A.10 Overcurrent	ON	OFF	OFF	OFF

OFF: Output transistor is OFF
 ON: Output transistor is ON

Status When Alarm Occurred

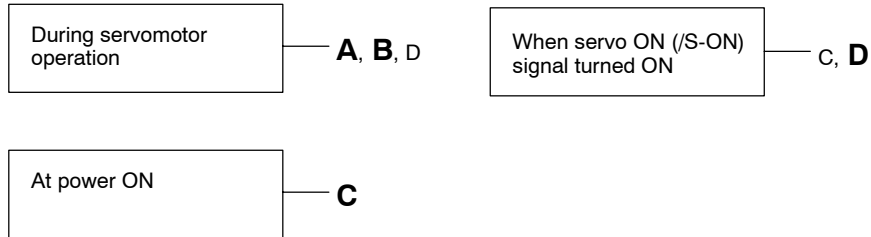

	Cause	Remedy
A	Wiring grounded between SERVOPACK and servomotor.	Check and correct wiring.
B	Servomotor U, V, or W phase grounded.	Replace servomotor.
C	<ul style="list-style-type: none"> • Circuit board (1PWB) defective • Power transistor defective 	Replace SERVOPACK.
D	Current feedback circuit, power transistor, DB circuit, or circuit board defective.	Replace SERVOPACK.

Email: service@repairtw.com

Line id: @zzzz

www.repairtw.com

■ A.30

Display and Outputs

Digital Operator Display and Alarm Name	Alarm Output			
	Alarm Code Output			Alarm Output
	ALO1	ALO2	ALO3	
A.30 Regenerative error detection	ON	ON	OFF	OFF

OFF: Output transistor is OFF

ON: Output transistor is ON

Status When Alarm Occurred

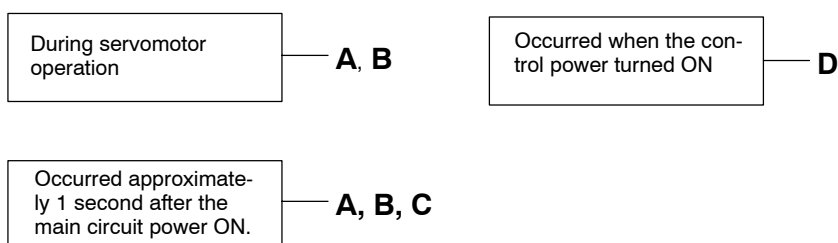

	Cause	Remedy
A	Regenerative transistor is abnormal.	Replace SERVOPACK.
B	Disconnection of the regenerative resistor unit.	Replace SERVOPACK or regenerative resistor unit.
C	Regenerative resistor unit disconnected (for more than 6.0 kW).	Check wiring of the regenerative resistor unit.
D	SERVOPACK defective. 037-466333	Replace SERVOPACK.

Email: service@repairtw.com

Line id: @zzzz

www.repairtw.com

■ A.31

Display and Outputs

Digital Operator Display and Alarm Name	Alarm Output			
	Alarm Code Output			Alarm Output
	ALO1	ALO2	ALO3	
A.31 Position error pulse overflow	ON	ON	OFF	OFF

OFF: Output transistor is OFF
ON: Output transistor is ON

Status When Alarm Occurred

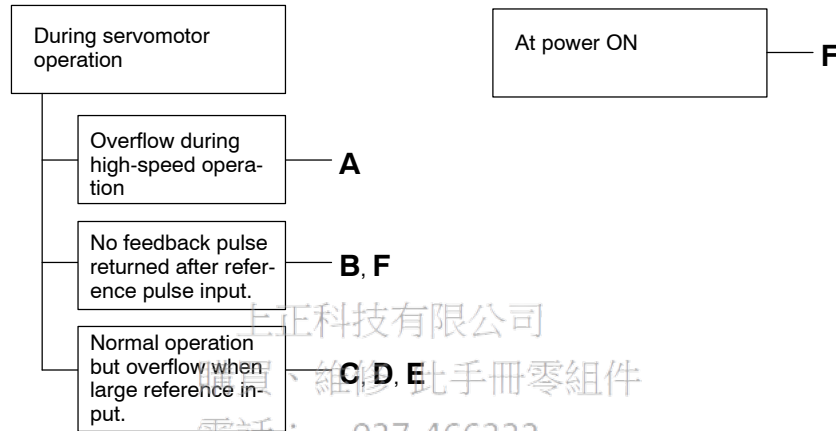

	Cause	Remedy
A	Servomotor wiring incorrect.	Check and correct wiring. (Check A-, B-, C-phase pulses correct at 2CN.)
B	Encoder wiring incorrect (disconnection, shortcircuit, power supply, etc.)	
C	SERVOPACK adjustment incorrect	Increase speed loop gain (Cn-04) and/or position loop gain (Cn-1A).
D	Servomotor overloaded	Reduce load torque and inertia. Otherwise, replace with larger capacity servomotor.
E	Position reference pulse frequency too high	<ul style="list-style-type: none"> • Decrease reference pulse frequency. • Use smoothing function. • Change electronic gear ratio.
F	Circuit board (1PWB) defective.	Replace SERVOPACK.

■ A.40

Display and Outputs

Digital Operator Display and Alarm Name	Alarm Output			
	Alarm Code Output			Alarm Output
	ALO1	ALO2	ALO3	
A.40 Main circuit voltage error detection.	OFF	OFF	ON	OFF

OFF: Output transistor is OFF

ON: Output transistor is ON

Status When Alarm Occurred

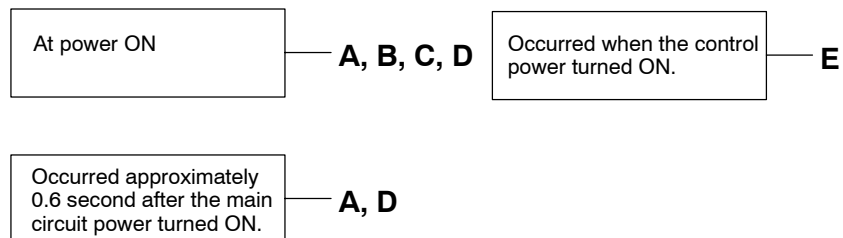

	Cause	Remedy
A	The power supply voltage is not within the range of specifications.	Check power supply.
B	Load exceeds capacity of the regenerative unit.	Check specifications of load inertia and overhanging load.
C	Regenerative transistor is abnormal.	Replace SERVOPACK.
D	<ul style="list-style-type: none"> • Rectifying diode defective. • Fuse blown • Inrush current-limited resistor disconnected. 	
E	SERVOPACK defective.	

■ A.51

Display and Outputs

Digital Operator Display and Alarm Name	Alarm Output			
	Alarm Code Output			Alarm Output
	ALO1	ALO2	ALO3	
A.51 Overspeed	ON	OFF	ON	OFF

OFF: Output transistor is OFF
 ON: Output transistor is ON

Status When Alarm Occurred

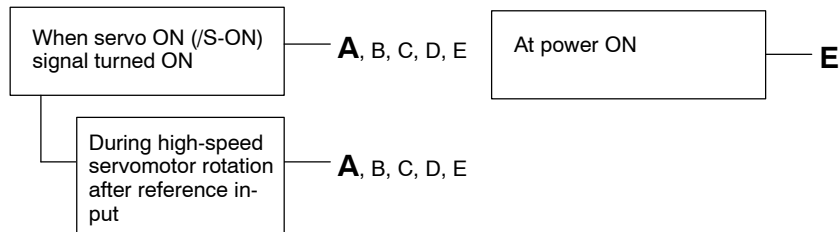

	Cause	Remedy
A	<ul style="list-style-type: none"> Servomotor wiring incorrect. Encoder wiring incorrect (disconnection, shortcircuit, power supply, etc.) 	Check and correct wiring. (Check A-, B-, C-phase pulses correct at 2CN.)
B	Incremental encoder power not supplied from SERVOPACK.	Use the SERVOPACK power supply for the encoder.
C	Noise in encoder wiring.	Separate encoder wiring from main wiring circuits.
D	Incorrect parameter (number of encoder pulses) setting.	Set parameter Cn-11 to the correct number of pulses.
E	Circuit board (1PWB) defective	Replace SERVOPACK.

■ A.71, A.72

Display and Outputs

Digital Operator Display and Alarm Name	Alarm Output			
	Alarm Code Output			Alarm Output
	ALO1	ALO2	ALO3	
A.71 Overload (High load) A.72 Overload (Low load)	ON	ON	ON	OFF

OFF: Output transistor is OFF
ON: Output transistor is ON

Status When Alarm Occurred

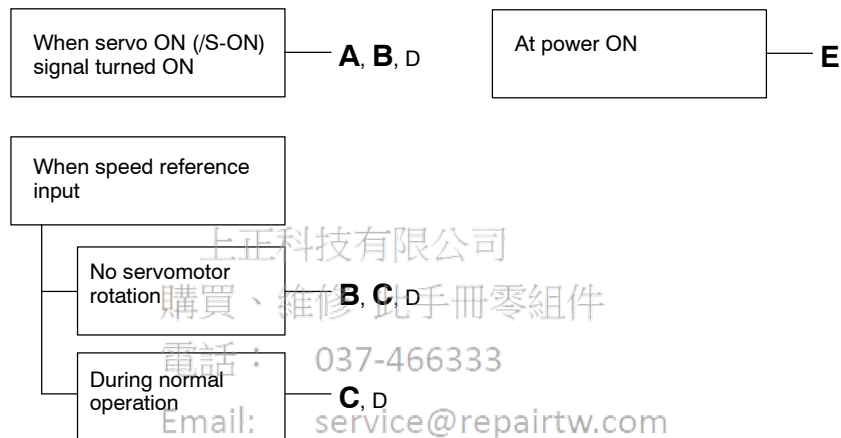

	Cause	Remedy
A	Servomotor wiring incorrect or disconnected	Check wiring and connectors at servomotor.
B	Encoder wiring incorrect or disconnected	Check wiring and connectors at encoder.
C	Load greatly exceeds rated torque	Reduce load torque and inertia. Otherwise, replace with larger capacity servomotor.
D	Incremental encoder power not supplied from SERVOPACK.	Use the SERVOPACK power supply for the encoder.
E	Circuit board (1PWB) defective	Replace SERVOPACK.

■ A.80

Display and Outputs

Digital Operator Display and Alarm Name	Alarm Output			
	Alarm Code Output			Alarm Output
	ALO1	ALO2	ALO3	
A.80 Absolute encoder error (only when absolute encoder is used)	OFF	OFF	OFF	OFF

OFF: Output transistor is OFF
ON: Output transistor is ON

Status When Alarm Occurred

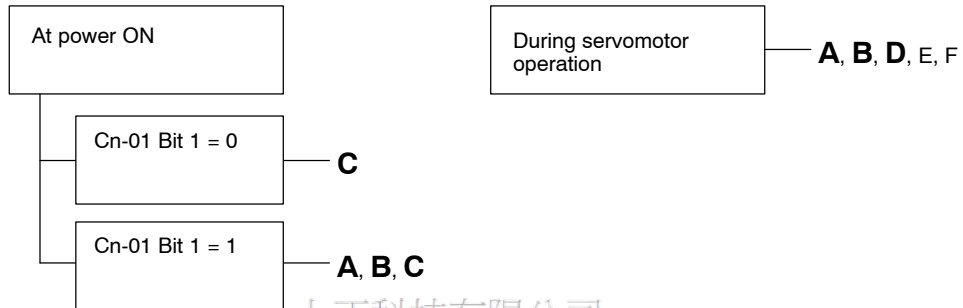

	Cause	Remedy
A	Incorrect absolute encoder wiring (PA, PB, RESET, SEN signal etc.)	Check and correct the absolute encoder wiring.
B	Absolute encoder malfunctioned	<ul style="list-style-type: none"> At Cn-01 Bit 1 = 0, turn SEN signal OFF then back ON. At Cn-01 Bit 1 = 1, turn SERVOPACK power OFF then back ON.
C	Circuit board (1PWB) defective	Replace SERVOPACK.
D	Error occurred in absolute encoder. Another encoder alarm displayed when SEN signal or power supply turned back ON.	<ul style="list-style-type: none"> At Cn-01 Bit 1 = 0, turn SEN signal OFF then back ON (if servomotor is running, first turn servo OFF). At Cn-01 Bit 1 = 1, turn SERVOPACK power OFF then back ON.
E	SERVOPACK miscounted pulses (positional displacement) or malfunctioned due to noise.	<ul style="list-style-type: none"> Separate encoder wiring from main wiring circuits. At Cn-01 Bit 1 = 0, turn SEN signal OFF then back ON (if servomotor is running, first turn servo OFF). At Cn-01 Bit 1 = 1, turn SERVOPACK power OFF then back ON.
F	Error occurred in incremental encoder.	<ul style="list-style-type: none"> Turn SERVOPACK power OFF then back ON. Replace servomotor.

■ A.81

Display and Outputs

Digital Operator Display and Alarm Name	Alarm Output			
	Alarm Code Output			Alarm Output
	ALO1	ALO2	ALO3	
A.81 Absolute encoder back-up error (only when 12 bit absolute encoder is used)	OFF	OFF	OFF	OFF

OFF: Output transistor is OFF
ON: Output transistor is ON

Status When Alarm Occurred

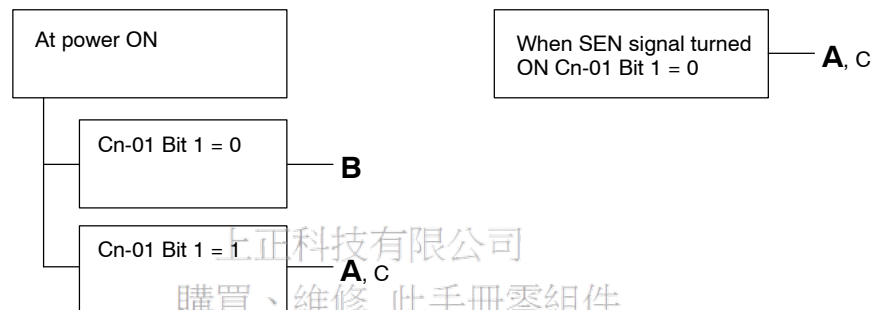

	Cause	Remedy
A	The following power supplied to the absolute encoder all failed: <ul style="list-style-type: none"> • +5 V supply • Battery (ER6V C3) • Internal capacitor 	Follow absolute encoder set-up procedures.
B	Circuit board (1PWB) defective	Replace SERVOPACK.
C	Absolute encoder malfunctioned	Replace servomotor.

■ A.82

Display and Outputs

Digital Operator Display and Alarm Name	Alarm Output			
	Alarm Code Output			Alarm Output
	ALO1	ALO2	ALO3	
A.82 Absolute encoder sum-check error (only when 12 bit absolute encoder is used)	OFF	OFF	OFF	OFF

OFF: Output transistor is OFF
ON: Output transistor is ON

Status When Alarm Occurred

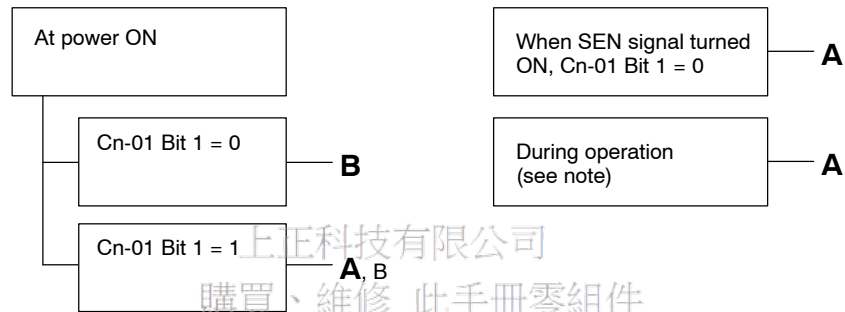

	Cause	Remedy
A	Abnormality during absolute encoder memory check	<ul style="list-style-type: none"> Follow absolute encoder set-up procedures. Replace servomotor if error occurs frequently.
B	Circuit board (1PWB) defective	Replace SERVOPACK.

Note An absolute encoder error (A.80) is given initially if a sum-check error (A.82) is generated during operation.
The sum-check error (A.82) occurs after turning the SEN signal (or SERVOPACK power supply) OFF and back ON.
However, the sum-check error (A.82) does occur during operation if the host controller is receiving the S-phase signal (serial data).

■ A.83

Display and Outputs

Digital Operator Display and Alarm Name	Alarm Output			
	Alarm Code Output			Alarm Output
	ALO1	ALO2	ALO3	
A.83 Absolute encoder sum-check error (only when 12 bit absolute encoder is used)	OFF	OFF	OFF	OFF

OFF: Output transistor is OFF
ON: Output transistor is ON

Status When Alarm Occurred

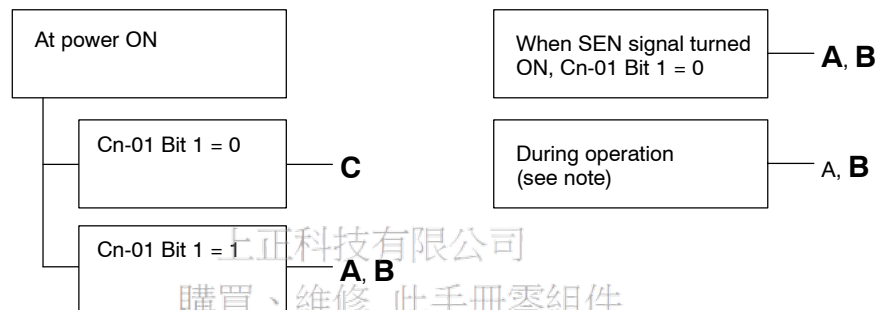

	Cause	Remedy
A	<ul style="list-style-type: none"> Battery not connected Battery connection defective 	Check and correct battery connection.
B	Battery voltage below specified value. Specified value: 2.8 V.	Install new battery and turn SEN signal (or SERVOPACK) ON.
C	Circuit board (1.PWB) defective	Replace SERVOPACK.

Note No alarm occurs at the SERVOPACK when a battery error (A.83) is generated. The battery error (A.83) occurs the next time the SEN signal (or SERVOPACK) turns ON. However, the battery error (A.83) can be read during operation if the host controller is receiving the S-phase signal (serial data).

■ A.84

Display and Outputs

Digital Operator Display and Alarm Name	Alarm Output			
	Alarm Code Output			Alarm Output
	ALO1	ALO2	ALO3	
A.84 Absolute encoder data error (only when absolute encoder is used)	OFF	OFF	OFF	OFF

OFF: Output transistor is OFF
ON: Output transistor is ON

Status When Alarm Occurred

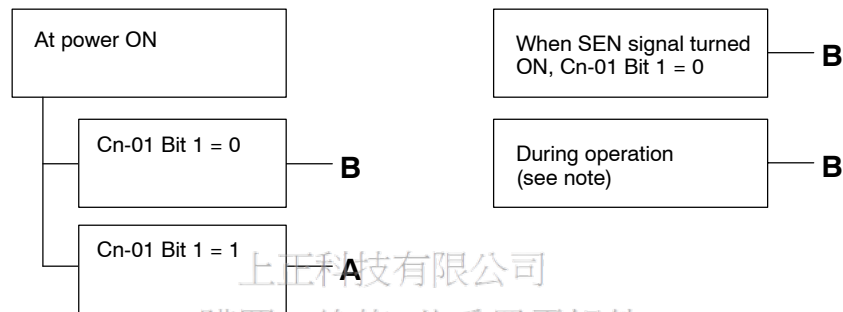

	Cause	Remedy
A	Absolute encoder malfunctioned	<ul style="list-style-type: none"> At Cn-01 Bit 1 = 0, turn SEN signal OFF then back ON. At Cn-01 Bit 1 = 1, turn SERVOPACK power OFF then back ON. Replace servomotor if error occurs frequently.
B	Circuit board (1PWB) defective	Replace SERVOPACK.

Note No alarm occurs at the SERVOPACK when a data error (A.84) is generated. The data error (A.84) occurs the next time the SEN signal (or SERVOPACK) turns ON. However, the data error (A.84) can be read during operation if the host controller is receiving the S-phase signal (serial data).

■ A.85

Display and Outputs

Digital Operator Display and Alarm Name	Alarm Output			
	Alarm Code Output			Alarm Output
	ALO1	ALO2	ALO3	
A.85 Absolute encoder overspeed (only when absolute encoder is used)	OFF	OFF	OFF	OFF

OFF: Output transistor is OFF
ON: Output transistor is ON

Status When Alarm Occurred

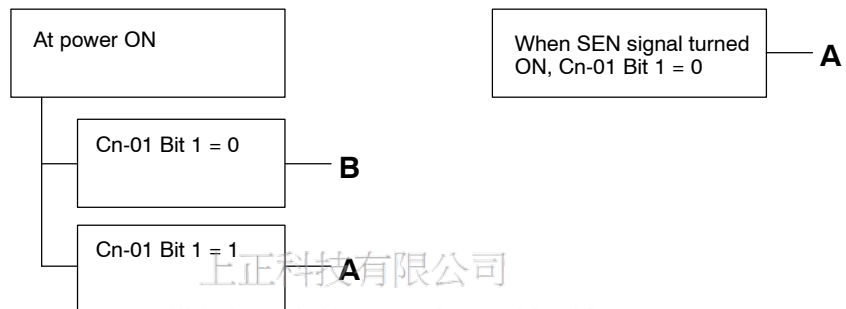

	Cause	Remedy
A	Absolute encoder turned ON at a speed exceeding 400 min ⁻¹ .	<ul style="list-style-type: none"> For speed control (at Cn-01 Bit 1 = 1) and for position control, turn SERVOPACK power OFF then back ON. Replace servomotor if error occurs frequently.
B	Circuit board (1PWB) defective	Replace SERVOPACK.

■ A.A1

Display and Outputs

Digital Operator Display and Alarm Name	Alarm Output			
	Alarm Code Output			Alarm Output
	ALO1	ALO2	ALO3	
A.A1 Heat sink overheated	ON	ON	ON	OFF

OFF: Output transistor is OFF
ON: Output transistor is ON

Status When Alarm Occurred



	Cause	Remedy
A	The ambient temperature of the SERVOPACK exceeds 55°C	Alter conditions so that the ambient temperature goes below 55°C
B	The air flow around the heat sink is bad.	Follow installing method and provide sufficient surrounding space as specified.
C	Fan stopped.	Replace SERVOPACK.
D	SERVOPACK is running under overload.	Reduce load.
E	SERVOPACK defective.	Replace SERVOPACK.

電話： 037-466333

Email: service@repairtw.com

Line id: @zzzz

www.repairtw.com

■ A.b1

Display and Outputs

Digital Operator Display and Alarm Name	Alarm Output			
	Alarm Code Output			Alarm Output
	ALO1	ALO2	ALO3	
A.b1 Reference input read error	OFF	OFF	OFF	OFF

OFF: Output transistor is OFF
ON: Output transistor is ON

Status When Alarm Occurred



	Cause	Remedy
A	Part malfunctioned in reference read-in unit (A/D converter, etc.).	Reset alarm and restart operation.
B	Part defective in reference read-in unit (A/D converter, etc.).	Replace SERVOPACK.
C	Circuit board (1PWB) defective	Replace SERVOPACK.

購買、維修 此手冊零組件

電話： 037-466333

Email: service@repairtw.com

Line id: @zzzz

www.repairtw.com

■ A.C1

Display and Outputs

Digital Operator Display and Alarm Name	Alarm Output			
	Alarm Code Output			Alarm Output
	ALO1	ALO2	ALO3	
A.C1 Servo overrun	ON	OFF	ON	OFF

OFF: Output transistor is OFF
ON: Output transistor is ON

Status When Alarm Occurred

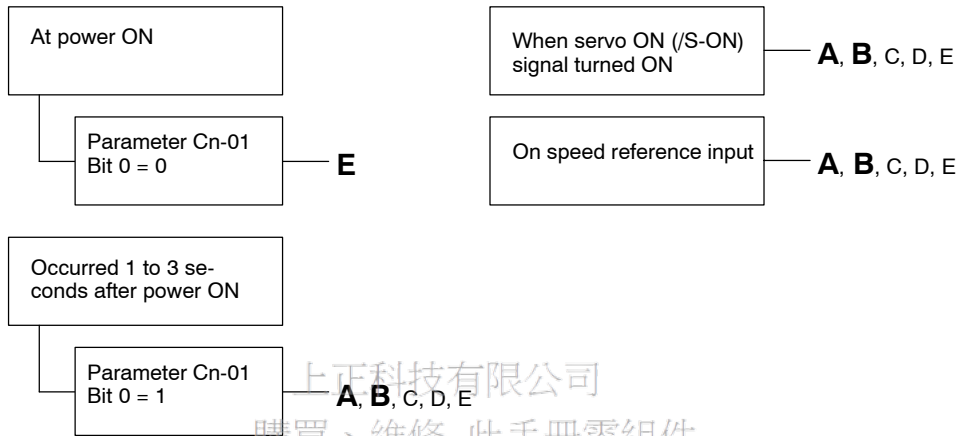

	Cause	Remedy
A	Servomotor wiring incorrect or disconnected	Check wiring and connectors at servomotor.
B	Encoder wiring incorrect or disconnected	Check wiring and connectors at encoder.
C	Incremental encoder power not supplied from SERVOPACK.	Use the SERVOPACK power supply for the encoder.
D	Encoder defective	Replace servomotor.
E	Circuit board (1PWB) defective	Replace SERVOPACK.

■ A.C2

Display and Outputs

Digital Operator Display and Alarm Name	Alarm Output			
	Alarm Code Output			Alarm Output
	ALO1	ALO2	ALO3	
A.C2 Encoder phase detection error	ON	OFF	ON	OFF

OFF: Output transistor is OFF
ON: Output transistor is ON

Status When Alarm Occurred

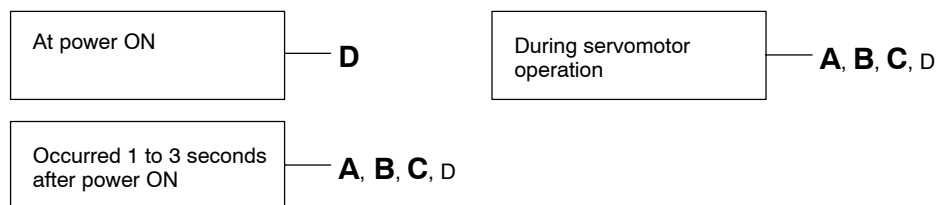

	Cause	Remedy
A	Noise in encoder wiring.	Separate encoder wiring from main wiring circuits.
B	Encoder wiring incorrect or poor connection.	Check wiring and connectors at encoder.
C	Encoder defective	Replace servomotor.
D	Circuit board (1PWB) defective	Replace SERVOPACK.

Email: service@repairtw.com

Line id: @zzzz

www.repairtw.com

■ A.C3

Display and Outputs

Digital Operator Display and Alarm Name	Alarm Output			
	Alarm Code Output			Alarm Output
	ALO1	ALO2	ALO3	
A.C3 Encoder A-, B-phase disconnection	ON	OFF	ON	OFF

OFF: Output transistor is OFF
ON: Output transistor is ON

Status When Alarm Occurred

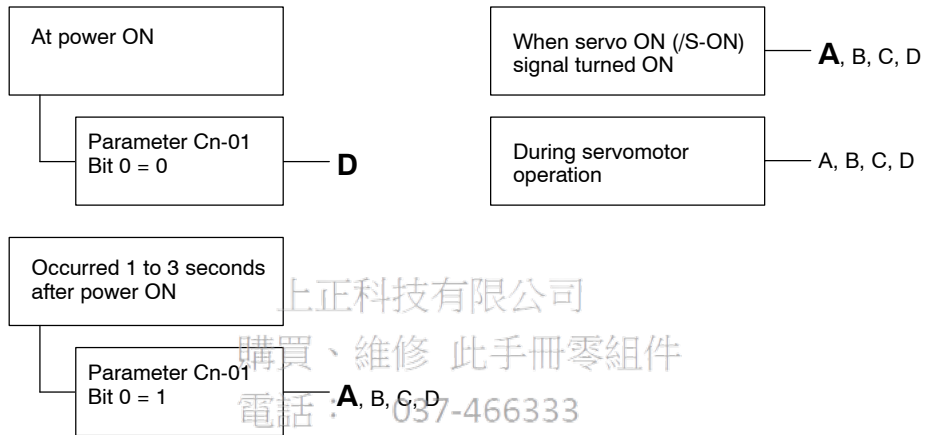

	Cause	Remedy
A	Encoder wiring incorrect or poor connection	Check wiring and connectors at encoder.
B	Noise in encoder wiring.	Separate encoder wiring from main wiring circuits.
C	Encoder defective	Replace servomotor.
D	Circuit board (1PWB) defective	Replace SERVOPACK.

6

■ A.C4

Display and Outputs

Digital Operator Display and Alarm Name	Alarm Output			
	Alarm Code Output			Alarm Output
	ALO1	ALO2	ALO3	
A.C4 Encoder C-phase disconnection	ON	OFF	ON	OFF

OFF: Output transistor is OFF
ON: Output transistor is ON

Status When Alarm Occurred

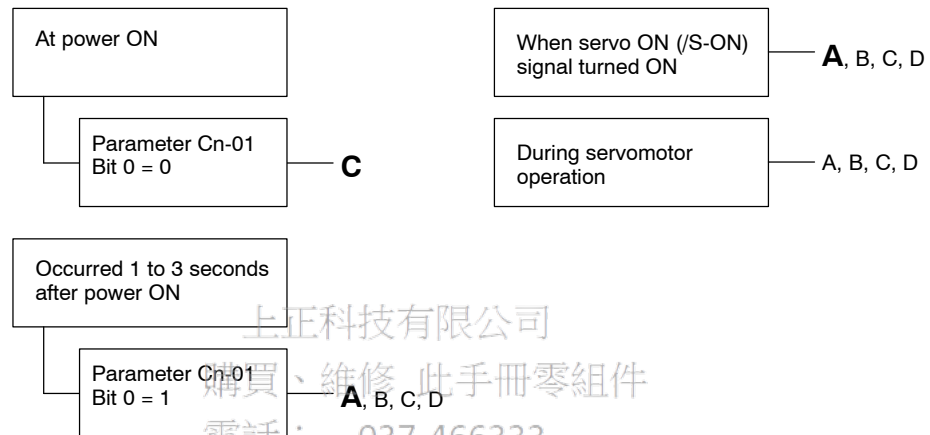

	Cause	Remedy
A	Encoder wiring incorrect or poor connection	Check wiring and connectors at encoder.
B	Noise in encoder wiring.	Separate encoder wiring from main wiring circuits.
C	Encoder defective	Replace servomotor.
D	Circuit board (1PWB) defective	Replace SERVOPACK.

■ A.F1

Display and Outputs

Digital Operator Display and Alarm Name	Alarm Output			
	Alarm Code Output			Alarm Output
	ALO1	ALO2	ALO3	
A.F1 Power line open phase	OFF	ON	OFF	OFF

OFF: Output transistor is OFF
ON: Output transistor is ON

Status When Alarm Occurred



	Cause	Remedy
A	One phase (R,S,T) of the main circuit power supply is disconnected.	<ul style="list-style-type: none"> • Check power supply. • Check wiring of the main circuit power supply. • Check MCCB, noise filter, magnetic contactor.
B	There is one phase where the line voltage is low.	Check power supply.
C	SERVOPACK defective.	Replace SERVOPACK.

上正科技有限公司
 購買、維修 此子冊零組件
 電話： 037-466333
 Email: service@repairtw.com
 Line id: @zzzz
 www.repairtw.com

■ A.F3

Display and Outputs

Digital Operator Display and Alarm Name	Alarm Output			
	Alarm Code Output			Alarm Output
	ALO1	ALO2	ALO3	
A.F3 Power loss error	OFF	ON	OFF	OFF

OFF: Output transistor is OFF

ON: Output transistor is ON

Status When Alarm Occurred



	Cause	Remedy
A	Although power loss alarm is not necessary, its parameter is set valid.	Set the parameter Cn-01 bit 5 to 0
B	Time between turning power OFF and back ON was shorter than 0.5 second.	After turning power OFF, wait for at least 0.5 second, before turning the power back ON.
C	If any of the following power supply conditions are met during motor operation: <ul style="list-style-type: none"> • Complete power failure : half cycle of supply frequency • Voltage drop: full cycle of supply frequency Note Because of detector lag or detector margin, there may be no alarm even if the above values are exceeded.	Check the power supply. Terms <ul style="list-style-type: none"> • Complete power failure=Power failure where voltage drops to zero. • Voltage drop=Power failure where voltage drops, but not to zero.

www.repairtw.com

■ CPF00

Display and Outputs

Digital Operator Display and Alarm Name	Alarm Output			
	Alarm Code Output			Alarm Output
	ALO1	ALO2	ALO3	
CPF00 Digital operator transmission error 1	Not specified			

Note This alarm is not stored in alarm trace-back function memory.

Status When Alarm Occurred

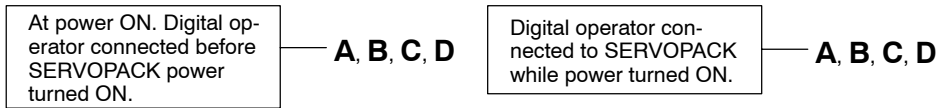

	Cause	Remedy
A	Cable defective or poor contact between digital operator and SERVOPACK.	<ul style="list-style-type: none"> • Check connector connections. • Replace cable.
B	Malfunction due to external noise	Separate digital operator and cable from noise source.
C	Digital operator defective	Replace digital operator.
D	SERVOPACK defective	Replace SERVOPACK.

6

上海亞細亞有限公司
 購買、維修 此手冊零件

電話： 037-466333

Email: service@repairtw.com

Line id: @zzzz

www.repairtw.com

■ CPF01

Display and Outputs

Digital Operator Display and Alarm Name	Alarm Output			
	Alarm Code Output			Alarm Output
	ALO1	ALO2	ALO3	
CPF01 Digital operator transmission error 2	Not specified			

Note This alarm is not stored in alarm trace-back function memory.

Status When Alarm Occurred

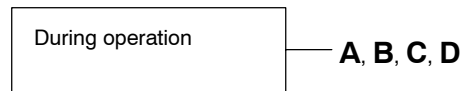

	Cause	Remedy
A	Cable defective or poor contact between digital operator and SERVOPACK.	<ul style="list-style-type: none"> • Check connector connections. • Replace cable.
B	Malfunction due to external noise	Separate digital operator and cable from noise source.
C	Digital operator defective	Replace digital operator.
D	SERVOPACK defective	Replace SERVOPACK.

購買、維修 此手冊零組件

電話： 037-466333

Email: service@repairtw.com

Line id: @zzzz

www.repairtw.com

■ A.99

Display and Outputs

Digital Operator Display and Alarm Name	Alarm Output			
	Alarm Code Output			Alarm Output
	ALO1	ALO2	ALO3	
A.99	OFF	OFF	OFF	ON

OFF: Output transistor is OFF

ON: Output transistor is ON

Status When Alarm Occurred

Indicates normal operation. Not an alarm.

上正科技有限公司

購買、維修 此手冊零組件

電話： 037-466333

Email: service@repairtw.com

Line id: @zzzz

www.repairtw.com

6.2.2 Troubleshooting Problems With No Alarm Display

Refer to the tables below to identify the cause of a problem which causes no alarm display and take the remedy described.

Turn OFF the servo system power supply before commencing the shaded procedures.

Contact your Yaskawa representative if the problem cannot be solved by the described procedures.

Troubleshooting Table No Alarm Display

Symptom	Cause	Inspection	Remedy
Servomotor does not start	Power not connected	Check voltage between power supply terminals.	Correct the power circuit.
	Loose connection	Check terminals of connectors (1CN, 2CN).	Tighten any loose parts.
	Connector (1CN) external wiring incorrect	Check connector (1CN) external wiring	Refer to connection diagram and correct wiring.
	Servomotor or encoder wiring disconnected.		Reconnect wiring
	Overloaded	Run under no load.	Reduce load or replace with larger capacity servomotor.
	Speed/position references not input	Check reference input pins.	Correctly input speed/position references.
	/S-ON is turned OFF	Cn-01 Bit 0 is 0.	Turn /S-ON input ON.
	/P-CON input function setting incorrect	Check parameter Cn-2B.	Refer to <i>Section 3.2.1</i> and set parameters to match application.
	Reference pulse mode selection incorrect.	Refer to <i>Section 3.2.2</i> .	Select correct parameters Cn-02 Bits 3, 4, 5.
	Encoder type differs from parameter setting.	Incremental or absolute encoder?	Set parameters Cn-01 Bit E to the encoder type used.
	P-OT and N-OT inputs are turned OFF.	(If Cn-01 Bits 2, 3 are 0)	Turn P-OT and N-OT input signals ON.
	CLR input is turned ON	Check status of error counter clear input.	Turn CLR input OFF.
SEN input is turned OFF.	Absolute encoder used with Cn-01 Bit 1 set to 0.	Turn SEN input ON.	
Servomotor moves instantaneously, then stops	Number of encoder pulses differs from parameter setting.		Set the parameter (Cn-11) to match the number of encoder pulses.
	Servomotor or encoder wiring incorrect.		Refer to <i>Section 3.8.8</i> and correct wiring.
Suddenly stops during operation and will not restart	Alarm reset signal (/ALM-RST) is turned ON because an alarm occurred.		Remove cause of alarm. Turn alarm reset signal (/ALM-RST) from ON to OFF.
Servomotor speed unstable	Wiring connection to motor defective	Check connection of power lead (U, V, and W phase) and encoder connectors.	Tighten any loose terminals or connectors.

INSPECTION, MAINTENANCE, AND TROUBLESHOOTING

6.2.2 Troubleshooting Problems With No Alarm Display cont.

Symptom	Cause	Inspection	Remedy
Servomotor vibrates at approximately 200 to 400 Hz.	Speed loop gain value too high.		Reduce speed loop gain (Cn-04) preset value.
	Speed/position reference input lead too long.		Minimize length of speed/position reference input lead, with impedance not exceeding several hundred ohms
	Speed/position reference input lead is bundled with power cables.		Separate reference input lead at least 30 cm from power cables.
High rotation speed overshoot on starting and stopping.	Speed loop gain value too high.		Reduce speed loop gain (Cn-04) preset value.
Servomotor overheated	Ambient temperature too high	Measure servomotor ambient temperature.	Reduce ambient temperature to 40°C max.
	Servomotor surface dirty	Visual check	Clean dust and oil from motor surface.
	Overloaded	Run under no load.	Reduce load or replace with larger capacity servomotor.
Abnormal noise	Mechanical mounting incorrect	Servomotor mounting screws loose?	Tighten mounting screws.
		Coupling not centered?	Center coupling.
		Coupling unbalanced?	Balance coupling.
	Bearing defective	Check noise and vibration near bearing.	Consult your Yaskawa representative if defective.
Machine causing vibrations	Foreign object intrusion, damage or deformation of sliding parts of machine.	Consult with machine manufacturer.	
Speed reference 0 V but servomotor rotates.	Speed reference voltage offset applied		Refer to <i>Sections 4.2.4</i> and <i>4.2.5</i> and adjust reference offset.

6.2.3 Internal Connection Diagram and Instrument Connection Examples

The SGDB SERVOPACK internal connection diagram and instrument connection examples are given below.
Refer to these diagrams during inspection and maintenance.

■ Internal Connection Diagram

- 0.3kW to 1.5kW

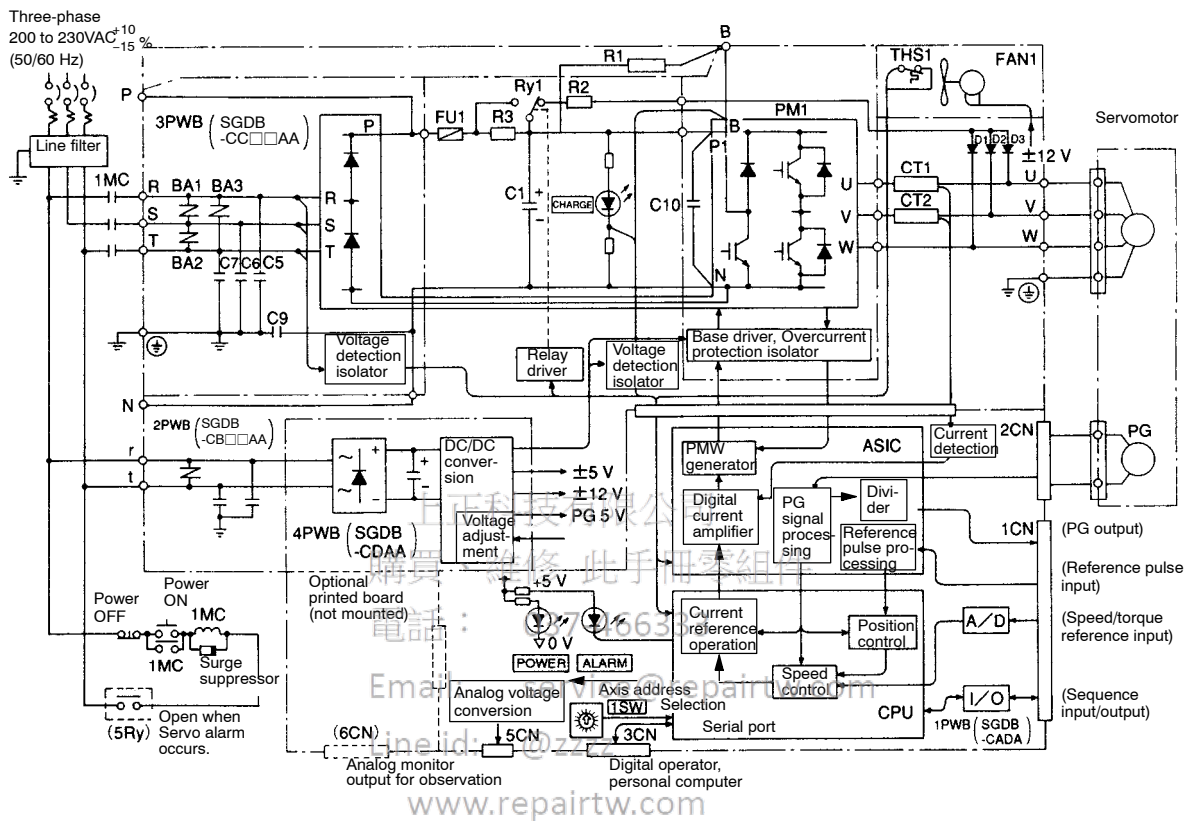

6.2.3 Internal Connection Diagram and Instrument Connection Examples cont.

• 2.0kW to 3.0kW

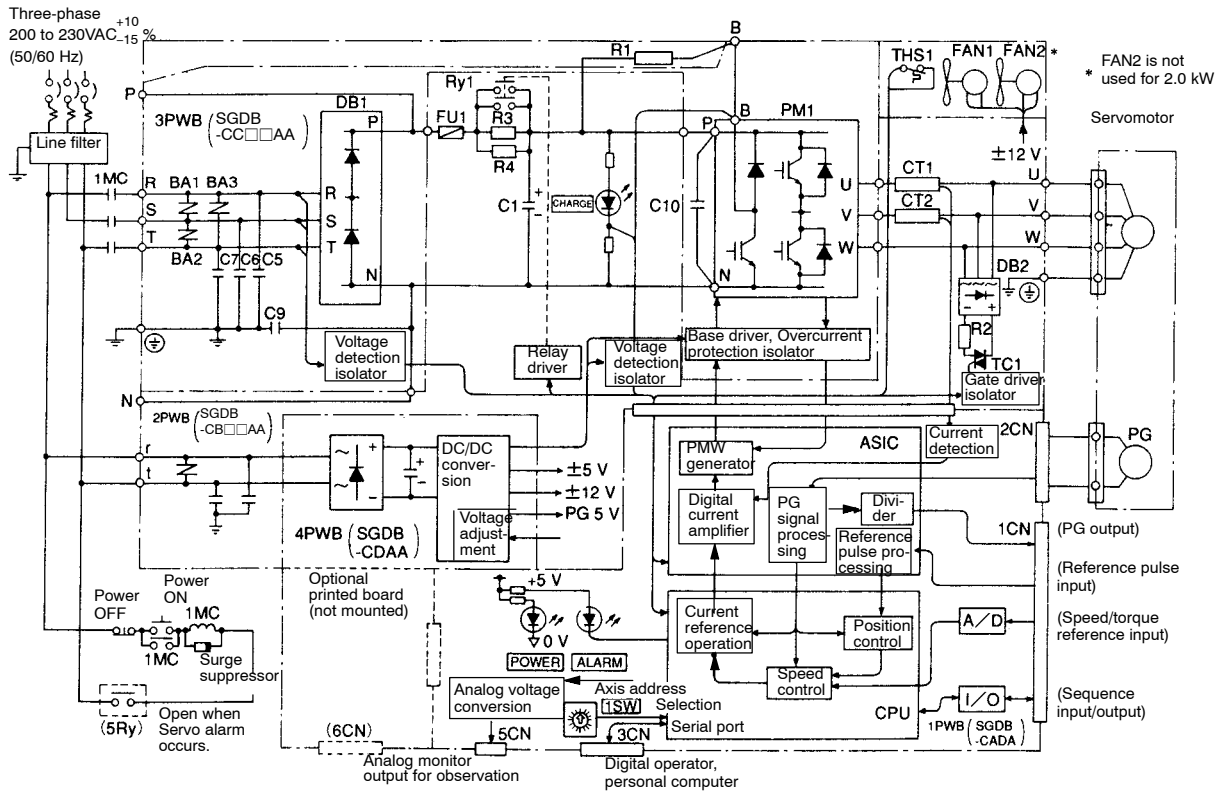

上正科技有限公司

購買、維修 此手冊零組件

電話： 037-466333

Email: service@repairtw.com

Line id: @zzzz

www.repairtw.com

• 4.4kW to 5.0kW

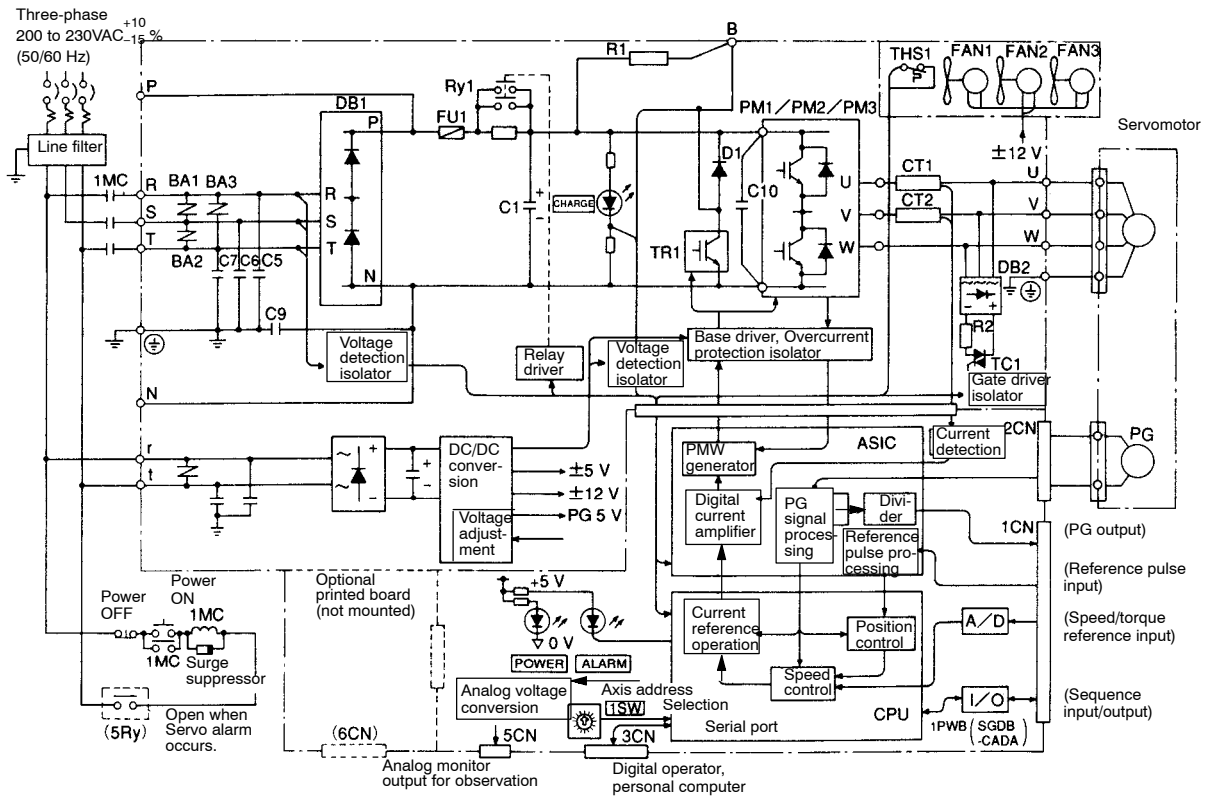

上正科技有限公司

購買、維修 此手冊零組件

電話： 037-466333

Email: service@repairtw.com

Line id: @zzzz

www.repairtw.com

6.2.3 Internal Connection Diagram and Instrument Connection Examples cont.

• 6.0kW to 15.0 kW

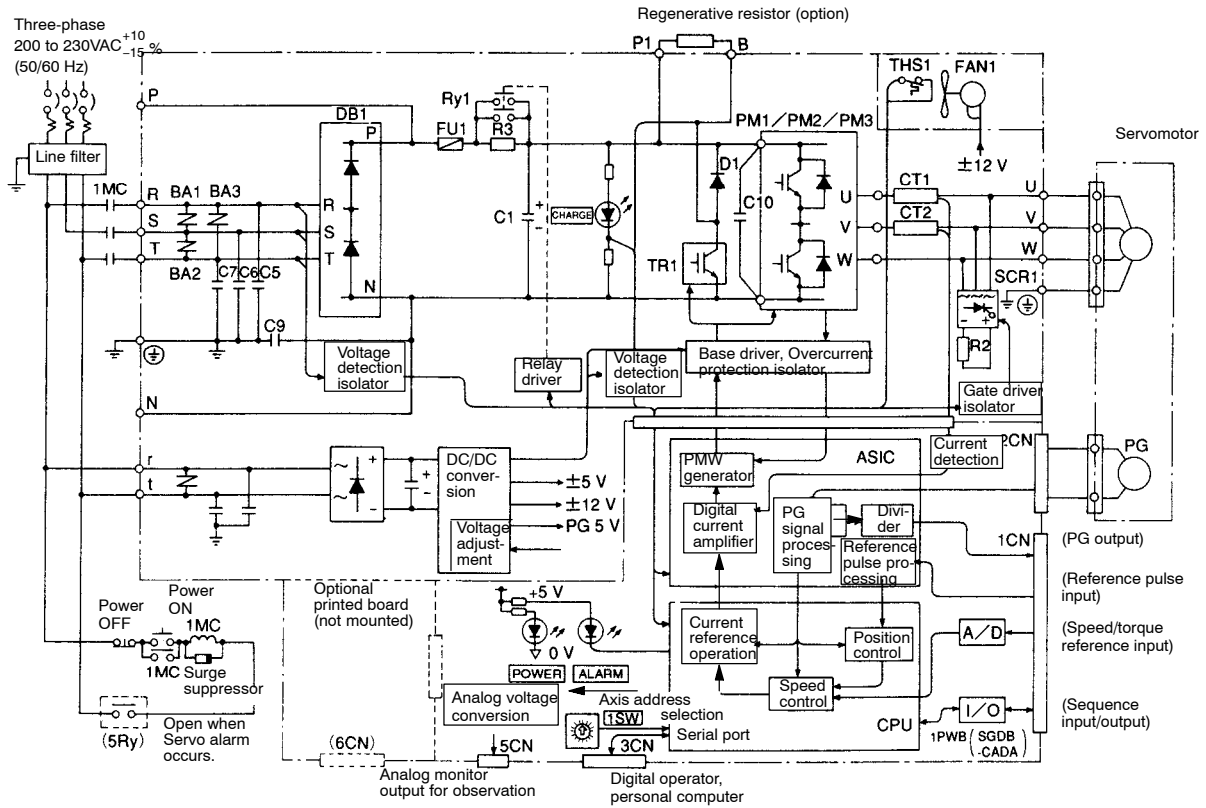

上正科技有限公司

購買、維修 此手冊零組件

電話： 037-466333

Email: service@repairtw.com

Line id: @zzzz

www.repairtw.com

■ Instrument connection examples

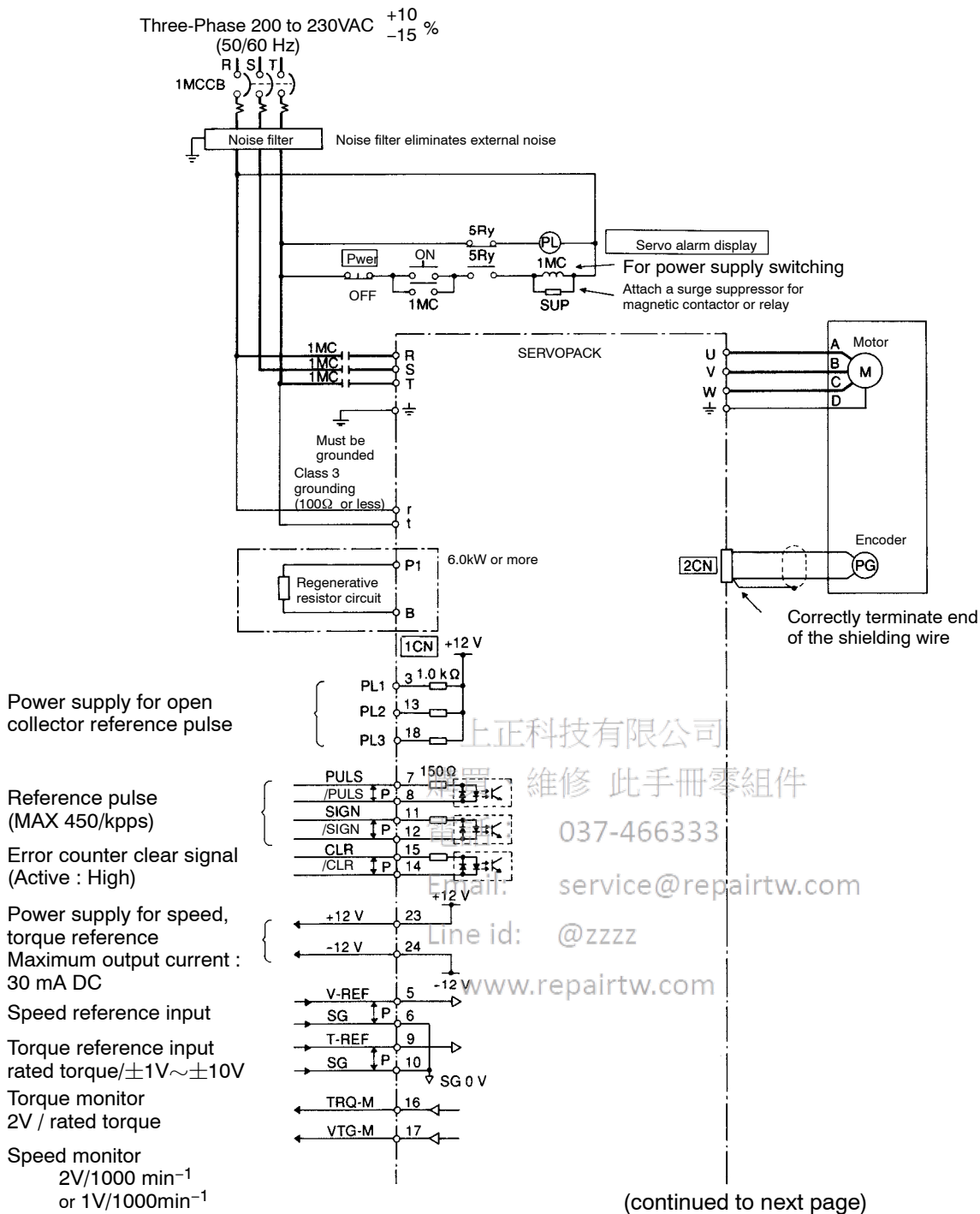

(continued to next page)

6.2.3 Internal Connection Diagram and Instrument Connection Examples cont.

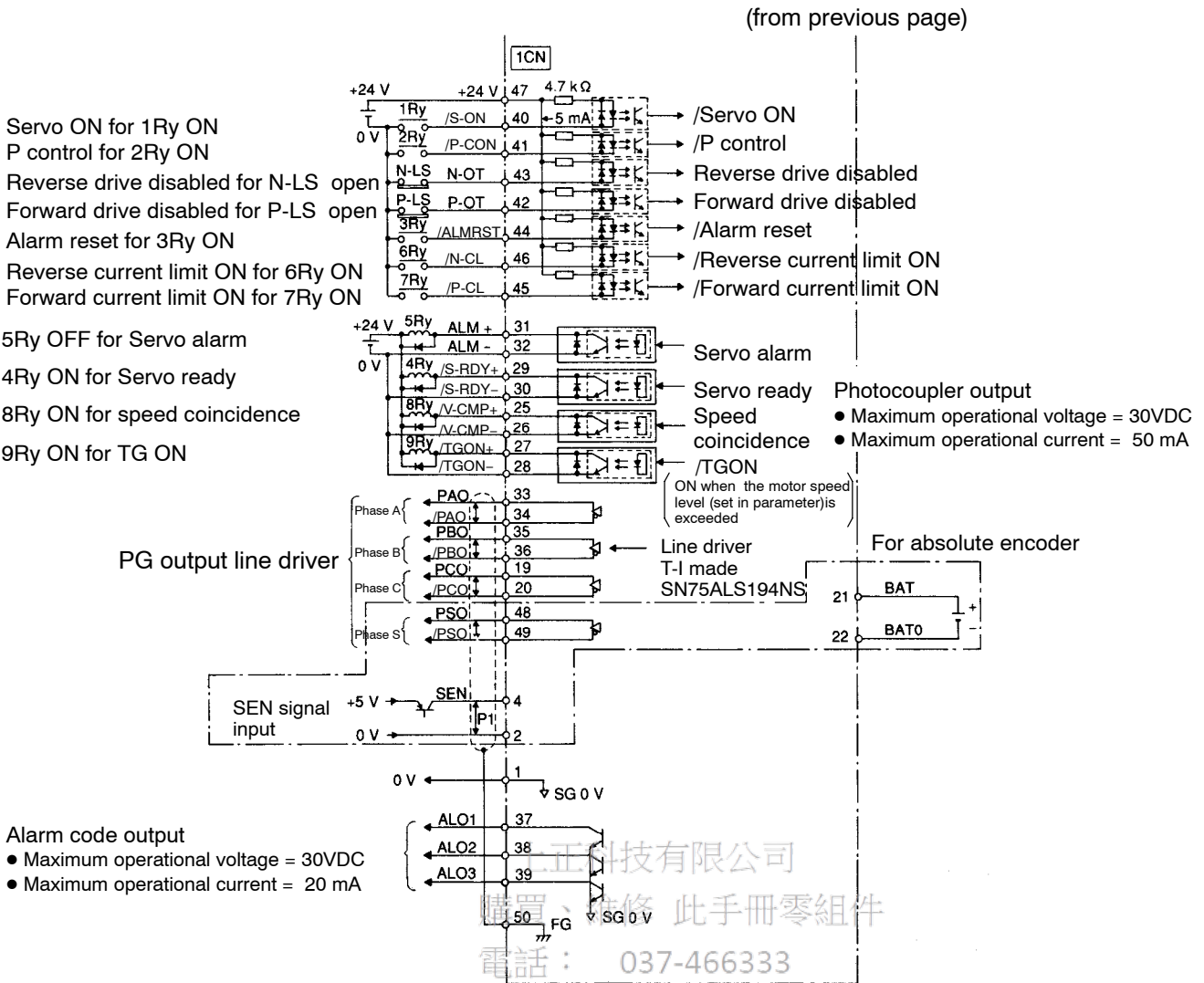

(Note)1 Signal input line represents twisted pair wires
 2 24V power supply must be prepared by customers

■ Connection method between SERVOPACK and Encoder

• In case of incremental encoder

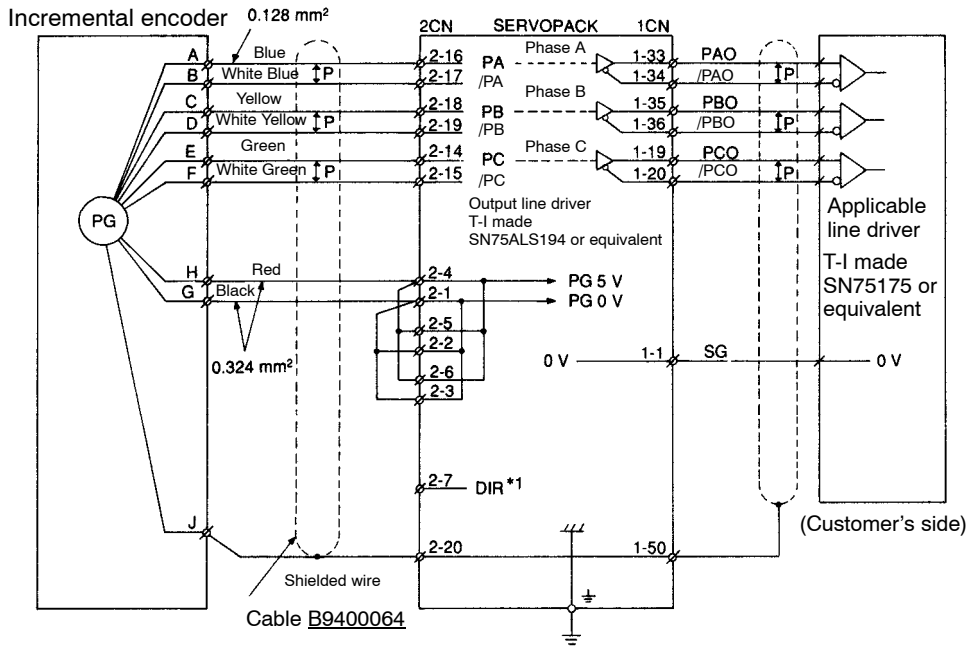

• In case of absolute encoder

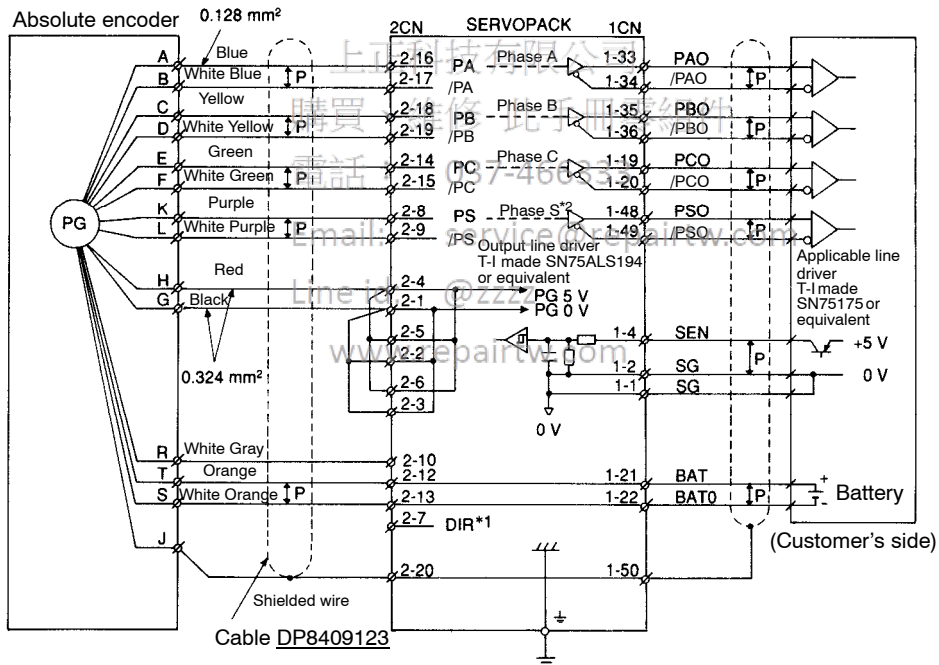

*1 By connecting DIR (2CN-7) to PG0V, the motor will be in reverse connection (motor reversed by forward reference).

*2 S phase signal is valid only when 12-bit absolute encoder is used.

Note $\overline{\text{P}}$ represents twisted pair wires.

Appendix A

Servo Adjustment

A

This appendix presents the basic rules for Σ -Series AC SERVOPACK gain adjustment, describes various adjustment techniques, and gives some preset values as guidelines.

A.1	Σ-Series AC SERVOPACK Gain Adjustment ..	476
A.1.1	Σ -Series AC SERVOPACKs and Gain Adjustment Methods .	476
A.1.2	Basic Rules for Gain Adjustment	477
A.2	Adjusting a Speed-control SERVOPACK	478
A.2.1	Adjusting Using Auto-tuning	478
A.2.2	Manual Adjustment	479
A.3	Adjusting a Position-control SERVOPACK	482
A.3.1	Adjusting Using Auto-tuning	482
A.3.2	Manual Adjustment	483
A.4	Gain Setting References	487
A.4.1	Guidelines for Gain Settings According to Load Inertia Ratio	487

A.1 Σ -Series AC SERVOPACK Gain Adjustment

This section gives some basic information required to adjust the servo system.

A.1.1 Σ -Series AC SERVOPACKs and Gain Adjustment Methods

Five types of Σ -Series AC SERVOPACK are available: SGD, SGDA, DR1, DR2, and the current SGDB.

The adjustment method is basically identical for each SERVOPACK type, except that auto-tuning is not available for some types.

The SGDB, SGDA, SGD, and DR2 SERVOPACKs allow both manual adjustment by the conventional method of observing the machine response and automatic adjustment using the internal auto-tuning function. The DR1 SERVOPACK does not offer auto-tuning.

The main parameters changed by the customer to adjust the servo system include the following:

- Cn-04 (Speed Loop Gain)
- Cn-05 (Speed Loop Integration Time Constant)
- Cn-17 (Torque Reference Filter Time Constant)
- Cn-1A (Position Loop Gain)

In a speed-control SERVOPACK (where speed references are applied as analog voltages), the position loop is controlled by the host controller, so the position loop gain is normally adjusted at the host controller.

If adjustment is not possible at the host controller, the same adjustment can be achieved using Cn-03 (Speed Reference Gain), but the servomotor may not reach maximum speed for some preset values of this parameter.

A simple block diagram of the servo system is shown below.

Servo System Block Diagram

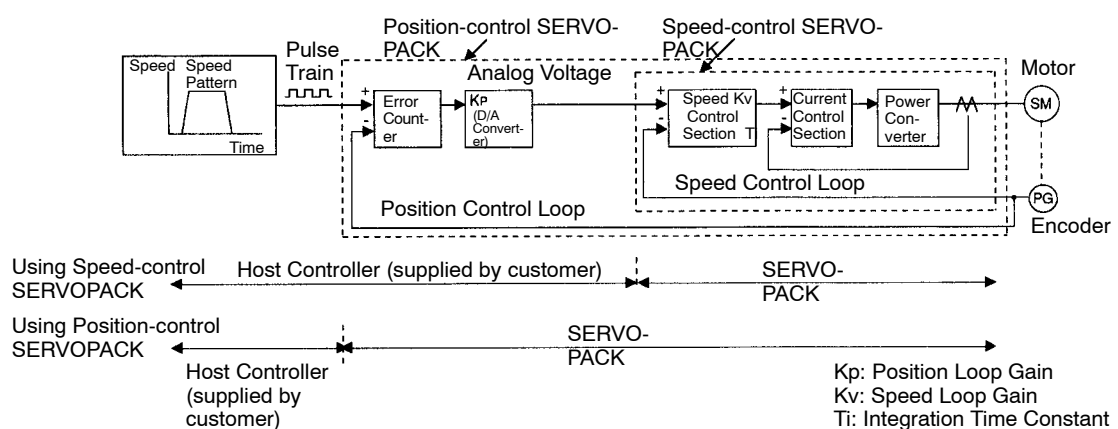

Note: A position-control SERVOPACK has no D/A converter for speed reference output. This conversion is handled by internal calculations.

A.1.2 Basic Rules for Gain Adjustment

- 1) The servo system comprises three feedback systems: position loop, speed loop, and current loop. The response must increase from outer loop to inner loop (see Servo System Block Diagram, above). The response deteriorates and oscillates if this principle is not obeyed.
The customer cannot adjust the current loop. Sufficient response is assured for the current loop.
The customer can adjust the position loop gain and speed loop gain, as well as the speed loop integration time constant and torque reference filter.
- 2) The position loop and speed loop must be adjusted to provide a balanced response. In particular, if the position loop gain only is increased (adjustment with Cn-03 at the SERVOPACK if position loop gain adjustment is not possible at the host controller), the speed references oscillate and the result is increased, oscillating position control times.
If the position loop gain (or Cn-03) is increased, the speed loop gain (Cn-04) must be similarly increased.
If the mechanical system starts to oscillate after the position loop gain and speed loop gain are increased, do not increase the gains further.
- 3) The position loop gain should not normally be increased above the characteristic frequency of the mechanical system.
For example, the harmonic gears used in an articulated robot form a structure with extremely poor rigidity and a characteristic frequency of approximately 10 to 20 Hz. This type of machine allows a position loop gain of only 10 to 20 (1/sec).
Conversely, the characteristic frequency of a precision machine tool such as a chip mounter or IC bonder exceeds 70 Hz, allowing a position loop gain exceeding 70 (1/sec) for some machines.
Therefore, although the response of the servo system (controller, servo driver, motor, detectors, etc.) is an important factor where good response is required, it is also important to improve the rigidity of the mechanical system.
- 4) In cases where the position loop response is greater than or equal to the speed loop response and linear acceleration or deceleration is attempted, the poor speed loop response and follow-up cause an accumulation of position loop errors and result in increased output of speed references from the position loop.
The motor moves faster and overshoots as a result of increased speed references, and the position loop tends to decrease the speed references. However, the poor motor follow-up due to the poor speed loop response results in oscillating speed references, as shown in the diagram below.
If this problem occurs, reduce the position loop gain or increase the speed loop gain to eliminate the speed reference oscillations.

Speed Reference Output with Unbalanced Position Loop Gain and Speed Loop Gain

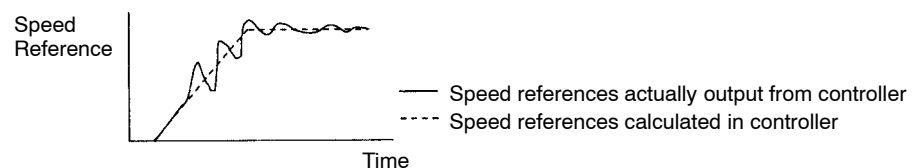

A.2 Adjusting a Speed-control SERVOPACK

This section gives examples of adjusting the gains of a speed-control SERVOPACK manually and using auto-tuning.

A.2.1 Adjusting Using Auto-tuning

The DR1 SERVOPACK does not offer auto-tuning.

■ Important Points About Auto-tuning

- Speed During Auto-tuning
Auto-tuning may not function correctly if the speed is too low. Set the speed to approximately 500 min^{-1} .
Set the speed with the parameter Cn-10 (Jog speed).
- Selecting Machine Rigidity
If the machine rigidity is unknown, select the rigidity according to the following standards.

Drive Method	Machine Rigidity	
	SGDB, SGDA, DR2	SGD
Ball screw, direct	3 (C-003) to 7 (C-007)	High/medium response
Ball screw, with reduction gears	2 (C-002) to 3 (C-003)	Medium response
Timing belt	1 (C-001) to 3 (C-003)	Low/medium response
Chain	1 (C-001) to 2 (C-002)	Low response
Wave reduction gears*	1 (C-001) to 2 (C-002)	Low response

* Product name: Harmonic Drive @ zzzz

Select the machine rigidity level for SGDB, SGDA and DR2 according to the table.

Level	Rigidity
7 (C-007)	High
6 (C-006)	:
5 (C-005)	:
4 (C-004)	:
3 (C-003)	Medium
2 (C-002)	:
1 (C-001)	Low

Auto-tuning may not end if high response is selected for a low-rigidity machine or low response is selected for a high-rigidity machine.

If this occurs, halt the auto-tuning and change the machine rigidity selection.

■ If Auto-tuning is Unsuccessful

Auto-tuning may be unsuccessful (the end of auto-tuning not displayed) for machines with large play or extremely low rigidity.

Similarly, auto-tuning may be unsuccessful for a machine with high load inertia (exceeding 15 to 30 times the motor moment of inertia).

In these cases, use conventional manual adjustment.

Even if auto-tuning is successful for a machine with large fluctuations in load inertia or load torque, vibrations or noise may still occur in some positions.

■ Response During Operation is Unsatisfactory after Auto-tuning

Auto-tuning sets the gain and integration time constant with some safety margin (to avoid oscillations). This can result in long positioning times.

In particular, the target position may not be reached if low response is selected, because the machine does not move in response to the final minute references. An excessively high setting of the integration time constant (Cn-05) during auto-tuning is one cause of this problem.

If response is slow after auto-tuning, the speed loop gain cannot be manually increased very much before oscillation starts.

In this case, manually reduce the integration time constant while observing the machine behavior to ensure oscillation does not occur.

Auto-tuning does not set the torque reference filter (Cn-17) or speed reference gain (Cn-03).

A.2.2 Manual Adjustment

■ Parameters

The role of each parameter is briefly described below.

• Speed Loop Gain (Cn-04)

This parameter sets the speed loop response.

The response is improved by setting this parameter to the maximum value in the range which does not cause vibrations in the mechanical system.

The following formula relates the speed loop gain to the load inertia.

$$\text{Speed Loop Gain } K_v \text{ [Hz]} = \frac{2}{\frac{GD_L^2}{GD_M^2} + 1} \times (\text{Cn-04 Preset value})$$

GD_L^2 : Motor Axis Converted Load Inertia

GD_M^2 : Motor Moment of Inertia

• Speed Loop Integration Time Constant (Cn-05)

The speed loop has an integration element to allow response to micro-inputs.

This integration element can produce a delay in the servo system, and the positioning setting time increases and response becomes slower as the time constant increases.

However, the integration time constant must be increased to prevent machine vibration if the load inertia is large or the mechanical system includes a element that is prone to vibration.

The following formula calculates a guideline value.

$$T_i \geq 2.3 \times \frac{1}{2\pi \times K_v}$$

T_i: Integration Time Constant (sec)

K_v: Speed Loop Gain (Hz) (calculated above)

- Torque Reference Filter Time Constant (Cn-17)

When a ball screw is used, torsional resonance may occur which increases the pitch of the vibration noise.

This vibration can sometimes be overcome by increasing the torque reference filter time constant.

However, this filter will produce a delay in the servo system, just like the integration time constant, and its value should not be increased more than necessary.

- Speed Reference Gain (Cn-03)

Changing the speed reference gain (Cn-03) changes the position loop gain an equivalent amount. That is, reducing the speed reference gain is equivalent to reducing the position loop gain and increasing it is equivalent to increasing the position loop gain. Use this parameter (Cn-03) in the following circumstances:

- No position loop gain adjustment at host controller (including cases where fine adjustment not possible by changing number of D/A converter bits)
- Clamping the speed reference output range to specific speeds

Normally leave at the factory setting.

NOTE For a speed-control SGD or SGDA SERVOPACK, or SGDB or DR2 SERVOPACK used for speed control, the position loop gain (Cn-1A) is valid in zero-clamp mode only. The position loop gain (Cn-1A) parameter is always invalid for a DR1 SERVOPACK. For normal control, change the position loop gain at the host controller or adjust the speed reference gain (Cn-03) in the SERVOPACK. Changing Cn-1A does not change the position loop gain.

■ Adjustment Procedure

1. Set the position loop gain at the host controller to a low value and increase the speed loop gain (Cn-04) within the range that no abnormal noise or vibration occurs. If adjustment of the position loop gain is not possible at the host controller, reduce the speed reference gain (Cn-03).
2. Slightly reduce the speed loop gain from the value at step 1, and increase the position loop gain at the host controller in the range that no overshooting or vibration occurs. If adjustment of the position loop gain is not possible at the host controller, increase the speed reference gain (Cn-03).

3. Determine the speed loop integration time constant (Cn-05), by observing the positioning setting time and vibrations in the mechanical system.
The positioning setting time may become excessive if the speed loop integration time constant (Cn-05) is too large.
4. It is not necessary to change the torque reference filter time constant (Cn-17) unless torsional resonance occurs in the machine shafts.
Torsional resonance may be indicated by a high vibration noise. Adjust the torque reference filter time constant (Cn-17) to reduce the vibration noise.
5. Finally, fine adjustment of the position gain, speed gain, and integration time constant is required to determine the optimum point for step response.

A

上正科技有限公司

購買、維修 此手冊零組件

電話： 037-466333

Email: service@repairtw.com

Line id: @zzzz

www.repairtw.com

A.3 Adjusting a Position-control SERVOPACK

This section gives examples of adjusting the gains of a position-control SERVOPACK manually and using auto-tuning.

A.3.1 Adjusting Using Auto-tuning

The DR1 SERVOPACK does not offer auto-tuning.

■ Important Points About Auto-tuning

- Speed During Auto-tuning
Auto-tuning may not function correctly if the speed is too low. Set the speed to approximately 500 min^{-1} .
Set the speed with the parameter Cn-10 (Jog speed).
- Selecting Machine Rigidity
If the machine rigidity is unknown, select the rigidity according to the following standards.

Drive Method	Machine Rigidity	
	SGDB, SGDA, DR2	SGD
Ball screw, direct	3 (C-003) to 7 (C-007)	High/medium response
Ball screw, with reduction gears	2 (C-002) to 3 (C-003)	Medium response
Timing belt	1 (C-001) to 3 (C-003)	Low/medium response
Chain	1 (C-001) to 2 (C-002)	Low response
Wave reduction gears*	1 (C-001) to 2 (C-002)	Low response

* Product name: Harmonic Drive @ zzzz

Select the machine rigidity level for SGDB, SGDA and DR2 according to the table.

Level	Rigidity
7 (C-007)	High
6 (C-006)	:
5 (C-005)	:
4 (C-004)	:
3 (C-003)	Medium
2 (C-002)	:
1 (C-001)	Low

Auto-tuning may not end if high response is selected for a low-rigidity machine or low response is selected for a high-rigidity machine.

If this occurs, halt the auto-tuning and change the machine rigidity selection.

■ If Auto-tuning is Unsuccessful

Auto-tuning may be unsuccessful (the end of auto-tuning not displayed) for machines with large play or extremely low rigidity.

Similarly, auto-tuning may be unsuccessful for a machine with high load inertia (exceeding 15 to 30 times the motor moment of inertia).

In these cases, use conventional manual adjustment.

Even if auto-tuning is successful for a machine with large fluctuations in load inertia or load torque, vibrations or noise may still occur in some positions.

■ Response During Operation is Unsatisfactory after Auto-tuning

Auto-tuning sets the gain and integration time constant with some safety margin (to avoid oscillations). This can result in long positioning times.

In particular, the target position may not be reached if low response is selected, because the machine does not move in response to the final minute references. An excessively high setting of the integration time constant (Cn-05) during auto-tuning is one cause of this problem.

If response is slow after auto-tuning, the speed loop gain cannot be manually increased very much before vibration starts.

In this case, manually reduce the integration time constant while observing the machine behavior to ensure oscillation does not occur.

Auto-tuning does not set the torque reference filter (Cn-17).

A.3.2 Manual Adjustment

■ Parameters

The role of each parameter is briefly described below.

• Speed Loop Gain (Cn-04)

This parameter sets the speed loop response.

The response is improved by setting this parameter to the maximum value in the range which does not cause vibrations in the mechanical system.

The following formula relates the speed loop gain to the load inertia.

$$\text{Speed Loop Gain } K_v \text{ [Hz]} = \frac{2}{\frac{GD_L^2}{GD_M^2} + 1} \times (\text{Cn-04 Preset value})$$

GD_L^2 : Motor Axis Converted Load Inertia

GD_M^2 : Motor Moment of Inertia

• Speed Loop Integration Time Constant (Cn-05)

The speed loop has an integration element to allow response to micro-inputs.

This integration element can produce a delay in the servo system, and the positioning setting time increases and response becomes slower as the time constant increases.

However, the integration time constant must be increased to prevent machine vibration if the load inertia is large or the mechanical system includes a vibration elements. The following formula calculates a guideline value.

$$T_i \geq 2.3 \times \frac{1}{2\pi \times K_v}$$

T_i: Integration Time Constant (sec)

K_v: Speed Loop Gain (Hz) (calculated above)

- Torque Reference Filter Time Constant (Cn-17)

When a ball screw is used, torsional resonance may occur which increases the pitch of the vibration noise.

These vibrations can sometimes be overcome by increasing the torque reference filter time constant.

However, this filter can produce a delay in the servo system, as is the integration time constant, and its value should not be increased more than necessary.

- Position Loop Gain

The position loop gain parameter sets the servo system response.

The higher the position loop gain is set, the better the response and shorter the positioning times.

To enable a high setting of the position loop gain, increase the machine rigidity and raise the machine characteristic frequency.

Increasing the position loop gain only to improve the response can result in oscillating response of the overall servo system, that is, the speed references output from the position loop oscillate. Therefore, also increase the speed loop gain while observing the response.

■ Adjustment Procedure

1. Set the position loop gain to a low value and increase the speed loop gain (Cn-04) within the range that no abnormal noise or oscillation occurs.
2. Slightly reduce the speed loop gain from the value at step 1, and increase the position loop gain in the range that no overshooting or vibration occurs.
3. Determine the speed loop integration time constant (Cn-05), by observing the positioning set time and vibrations in the mechanical system.
The positioning set time may become excessive if the speed loop integration time constant (Cn-05) is too large.
4. It is not necessary to change the torque reference time constant (Cn-17) unless torsional resonance occurs in the machine shafts.
Torsional resonance may be indicated by a high vibration noise. Adjust the torque reference filter time constant to reduce the vibration noise.
5. Finally, fine adjustment of the position gain, speed gain, and integration time constant is required to determine the optimum point for step response, etc.

■ Functions to Improve Response

The mode switch, feed-forward, and bias functions improve response. However, they are not certain to improve response and may even worsen it in some cases. Follow the points outlined below and observe the actual response while making adjustments.

• Mode Switch

The mode switch improves the transition characteristics when the torque references become saturated during acceleration or deceleration.

Above the set level, the speed loop control switches from PI (proportional/integral) control to P (proportional) control.

• Feed-forward Function

Use feed-forward to improve the response speed. However, feed-forward may be ineffective in systems where a sufficiently high value of position loop gain is not possible. Follow the procedure below to adjust the feed-forward amount (Cn-1D).

1. Adjust the speed loop and position loop, as described above.
2. Gradually increase the feed-forward amount (Cn-1D), such that the positioning complete (/COIN) signal is output early.

At this point, ensure that the positioning complete (/COIN) signal breaks up (alternately turns ON/OFF) and that the speed does not overshoot. These problems can arise if the feed-forward is set too high.

For all types of SERVOPACK except DR1, a primary delay filter can be applied to feed-forward. This filter can be used to correct breakup (alternately turning ON/OFF) of the positioning complete (/COIN) signal or speed overshoot arising when feed-forward is activated.

• Bias Function

When the lag pulses in the error counter exceeds the positioning complete width (Cn-1B), the bias amount (Cn-1C) is added to the error counter output (speed reference). If the lag pulses in the error counter lies within the positioning complete width (Cn-1B), the bias amount (Cn-1C) is no longer added.

This reduces the number of pulses in the error counter and shortens the positioning time.

The motor speed becomes unstable if the bias amount is too large.

Observe the response during adjustment as the optimum value depends on the load, gain, and positioning complete width.

Set Cn-1C to zero (0) when the bias is not used.

Bias Function

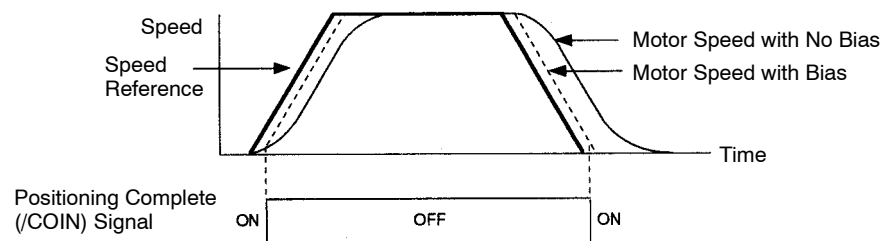

The adjustment procedures described above are common for all Yaskawa digital AC SERVOPACKs. However, not all functions are available on each SERVOPACK. Consult the technical specifications of your SERVOPACK for details.

The adjustment procedures are also identical for conventional analog servos. However, in this case, the adjustments are made using potentiometers instead of the parameters.

A

上正科技有限公司

購買、維修 此手冊零組件

電話： 037-466333

Email: service@repairtw.com

Line id: @zzzz

www.repairtw.com

A.4 Gain Setting References

This section presents tables of load inertia values for reference when adjusting the gain.

A.4.1 Guidelines for Gain Settings According to Load Inertia Ratio

A

Adjustment guidelines are given below according to the rigidity of the mechanical system and load inertia. Use these values as guidelines when adjusting according to the procedures described above.

These values are given as guidelines only. Oscillations and poor response may occur inside the specified value ranges. Observe the response (waveform) when optimizing the adjustment.

Higher gains are possible for machines with high rigidity.

■ Machines with High Rigidity

Ball Screw, Direct Drive Machines

Example: Chip moulder, IC bonder, precision machine tools

Load/Inertia Ratio (GD_L^2/GD_M^2)	Position Loop Gain (Cn-1A) [1/s]	Speed Loop Gain (Cn-04)	Speed Loop Integration Time Constant (Cn-05) [ms]
1 x	50 to 70	50 to 70	5 to 20
3 x		100 to 140	Slightly increase for inertia ratio of 20 x, or greater.
5 x		150 to 200	
10 x		270 to 380	
15 x		400 to 560	
20 x		500 to 730	
30 x		700 to 1100	

For an inertia ratio of 10 x, or greater, slightly reduce the position loop gain and speed loop gain below the values shown and set the integration time constant to a higher value before starting the adjustment.

As the inertia ratio increases, set the position loop gain and speed loop gain to the lower limit of the range of values specified. Conversely, increase the speed loop integration time constant.

■ Machines with Medium Rigidity

Machines driven by ball screw through reduction gears, or machines directly driven by long ball screws.

Example: General machine tools, orthogonal robots, conveyors

SERVO ADJUSTMENT

A.4.1 Guidelines for Gain Settings According to Load Inertia Ratio cont.

Load/Inertia Ratio (GD_L^2/GD_M^2)	Position Loop Gain (Cn-1A) [1/s]	Speed Loop Gain (Cn-04)	Speed Loop Integration Time Constant (Cn-05) [ms]
1 x	30 to 50	30 to 50	10 to 40 Slightly increase for inertia ratio of 20 x, or greater.
3 x		60 to 100	
5 x		90 to 150	
10 x		160 to 270	
15 x		240 to 400	
20 x		310 to 520	
30 x		450 to 770	

For an inertia ratio of 10 x, or greater, slightly reduce the position loop gain and speed loop gain below the values shown and set the integration time constant to a higher value before starting the adjustment.

As the inertia ratio increases, set the position loop gain and speed loop gain to the lower limit of the range of values specified. Conversely, increase the speed loop integration time constant.

■ Machines with Low Rigidity

Machines driven by timing belts, chains or wave reduction gears (product name: Harmonic Drive).

Example: Conveyors, articulated robots

Load/Inertia Ratio (GD_L^2/GD_M^2)	Position Loop Gain (Cn-1A) [1/s]	Speed Loop Gain (Cn-04)	Speed Loop Integration Time Constant (Cn-05) [ms]
1 x	10 to 20	10 to 20	50 to 120 Slightly increase for inertia ratio of 20 x, or greater.
3 x		20 to 40	
5 x		30 to 60	
10 x		50 to 110	
15 x		80 to 160	
20 x		100 to 210	
30 x		150 to 310	

For an inertia ratio of 10 x, or greater, slightly reduce the position loop gain and speed loop gain below the values shown and set the integration time constant to a higher value before starting the adjustment.

As the inertia ratio increases, set the position loop gain and speed loop gain to the lower limit of the range of values specified. Conversely, increase the speed loop integration time constant.

When a speed-control SERVOPACK is used, set the position loop gain at the host controller.

If the position loop gain cannot be set at the host controller, adjust the SERVOPACK speed reference gain (Cn-03).

The position loop gain (Cn-1A) of a speed-control SERVOPACK is valid in zero-clamp mode only.

The position loop gain is determined from the following relationship.

$$K_p = \frac{V_s}{\epsilon}$$

K_p [1/s]: Position loop gain

V_s [PPS]: Steady speed reference

ϵ : (pulse): Steady error

(The number of pulses in the error counter at steady speed.)

上正科技有限公司

購買、維修 此手冊零組件

電話： 037-466333

Email: service@repairtw.com

Line id: @zzzz

www.repairtw.com

A

Appendix B

List of I/O Signals

B

This appendix lists I/O signal terminals (connector 1CN) on SERVOPACKs which connect to a host controller or external circuit.

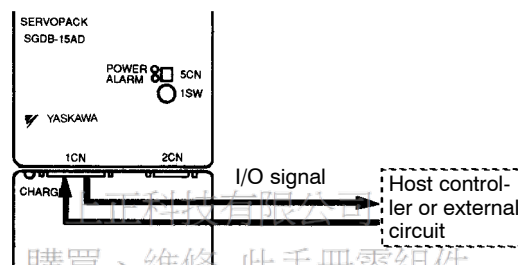

購買、維修 此手冊零組件

電話： 037-466333

NOTE 1) Refer to *Chapter 3* for details of how to use I/O signals.

Line id: @zzzz

2) Note that the functions of I/O signal terminals differ according to the memory switch (Cn-01, Cn-02) settings.

www.repairtw.com

List of Input Output Signals

Number “x.x.x” in box represents a section number corresponding to each signal name. For example, 3.2.1 represents Section 3.2.1.

1CN Terminal Number	Abbreviated symbol	Signal name		
1	SG	Signal ground		
2	SG	Signal ground		
3	PL1	Power supply for open collector reference	3.2.2	*2
4	SEN	Sensor ON	3.8.5	*6
5	V-REF	Speed reference input	3.2.1	*1
6	SG	Signal ground		
7	PULS	Reference pulse input	3.2.2	*2
8	/PULS			
9	T-REF	Torque reference input	3.2.7	*1
10	SG	Signal ground		
11	SIGN	Reference sign input	3.2.2	*2
12	/SIGN			
13	PL2	Power supply for open collector reference	3.2.2	*2
14	/CLR	Clear signal input	3.2.2	*2
15	CLR			
16	TRQ-M	Torque monitor	3.2.12	*3
17	VTG-M	Speed monitor	3.2.12	*3
18	PL3	Power supply for open collector reference	3.2.2	*2
19	PCO	C phase output signal	3.2.3	
20	/PCO			
21	BAT	Back-up battery input	3.8.5	*6
22	BAT0			
23	+12V	Power supply for analog reference	3.2.1	*1
24	-12V			
25	/V-CMP, /COIN+	Speed coincidence output/positioning completion signal	3.7.4 3.7.3	*4
26	/V-CMP, /COIN-	Speed coincidence output/positioning completion signal	3.7.4 3.7.3	*4
27	/TGON+	Rotating detection	3.7.5	*4
28	/TGON-			
29	/S-RDY+	Servo ready	3.7.7	*4
30	/S-RDY-			

B

31	ALM+	Alarm output	3.7.1	
32	ALM-			
33	PAO	A phase output signal	3.2.3	
34	/PAO			
35	PBO	B phase output signal	3.2.3	
36	/PBO			
37	ALO1	Alarm code output	3.7.1	
38	ALO2			
39	ALO3			
40	/S-ON	Servo ON	3.7.2	
41	/P-CON	Proportional control (P control) reference	3.2.1	*5
42	P-OT	Forward drive disabled	3.1.2	
43	N-OT	Reverse drive disabled	3.1.2	
44	/ALMRST	Alarm reset	3.7.1	
45	/P-CL	Forward torque limit	3.1.3	*5
46	/N-CL	Reverse torque limit	3.1.3	*5
47	+24 V IN	24V external power supply input	3.2.4	
48	PSO	S phase input signal	3.8.5	*6
49	/PSO			
50	FG	Frame ground	3.2.3	

- *1 Used for analog reference See page 558
- *2 Used for pulse reference See page 558
- *3 Specifications vary depending on bits 6, 7 of Cn-02 . . . refer to page 559
- *4 Specifications vary according to setting values of Cn-2D . . . refer to Appendix D (page 569)
- *5 Specifications vary according to setting values of Cn-2B . . . refer to page 559
- *6 Used only for absolute encoder (used only when bit E of Cn-01 equal to 1)

B

*1 Signals used for analog reference

For speed control

Specifications	Speed control		Speed control with torque limit by analog voltage reference		Speed control with torque feed-forward	
Setting	Cn-02 Bit 8 = 0 Bit 9 = 0		Cn-02 Bit 8 = 1 Bit 9 = 0		Cn-02 Bit 8 = 0 Bit 9 = 1	
1CN Terminal number						
5	V-REF	Speed reference	V-REF	Speed reference	V-REF	Speed reference
9	---	Terminal unused	T-REF	Torque limit input 3.2.9	T-REF	Torque feed-forward reference 3.2.8

For torque control

Specifications	Torque control		Torque control with speed limit by analog voltage reference	
Setting	Cn-02 Bit 2 = 0		Cn-02 Bit 2 = 1	
1CN Terminal number				
5	---	Terminal unused	V-REF	Speed limit value 3.1.3
9	T-REF	Torque reference	T-REF	Torque reference

*2 Signals used for pulse reference

Specifications	Sign + pulse train input reference		CCW pulse + CW pulse reference		Two phase pulse reference with 90° phase difference	
Setting	Cn-02 Bit 5 = 0 Bit 4 = 0 Bit 3 = 0		Cn-02 Bit 5 = 0 Bit 4 = 0 Bit 3 = 1		Cn-02 bits 5, 4, 3 = 0, 1, 0 (x1 multiplication) = 0, 1, 1 (x2 multiplication) = 1, 0, 0 (x4 multiplication)	
1CN Terminal number						
7	PULS	Reference pulse input	PULS	Forward reference pulse input (CCW) 3.2.2	PULS	A phase reference pulse input 3.2.2
8	/PULS		/PULS			
11	SIGN	Reference sign input	SIGN	Reverse reference pulse input (CW)	SIGN	B phase reference pulse input
12	/SIGN		/SIGN			

B

***3 Analog monitor signals**

Control mode	-----		Speed mode		Position control	Torque control
Setting	Cn-02 Bit 6 = 0		Cn-02 Bit 6 = 1			
1CN Terminal number						
16	TRQ-M	Torque monitor	TRQ-M	Speed reference monitor	Reference pulse speed monitor	×
Setting	Cn-02 Bit 7 = 0		Cn-02 Bit 7 = 1			
1CN Terminal number						
17	VTG-M	Speed monitor	VTG-M	×	Position error monitor	×

Note x means don't care for voltage values.

***5**

Specifications	Speed control Position control		Torque control		Speed control (contact reference)	
Setting	Cn-2B = 0, 1		Cn-2B = 2		Cn-2B = 3, 4, 5, 6	
1CN Terminal number						
41	/P-CON	Proportional control reference	--	Terminal unused	/P-CON	Rotation direction reference for contact input speed selection
45	/P-CL	Forward (Reverse) torque limit	/P-CL	Forward (Reverse) torque limit	/P-CL	Contact input speed selection (control mode switching)
46	/N-CL		/N-CL		/N-CL	

Specifications	Position ↔ Speed Position ↔ Torque Torque ↔ Speed		Speed control with zero clamp		Position control with reference pulse inhibit function	
Setting	Cn-2B = 7, 8, 9		Cn-2B = 10		Cn-2B = 11	
1CN Terminal number						
41	/P-CON	Control mode switching signal	/P-CON	Zero clamp operation reference	/P-CON	Reference pulse inhibit reference
45	/P-CL	Forward (Reverse) torque limit	/P-CL	Forward (Reverse) torque limit	/P-CL	Forward (Reverse) torque limit
46	/N-CL		/N-CL		/N-CL	

B

Appendix C

List of Parameters

Σ -Series SERVOPACKs provide many functions, and have parameters called “parameters” to allow the user to select each function and perform fine adjustment. This appendix lists these parameters.

Parameters are divided into the following two types:

1) Memory switch Cn-01, Cn-02	Each bit of this switch is turned ON or OFF to select a function.
2) Parameter setting Cn-03 and later	A numerical value such as a torque limit value or speed loop gain is set in this constant.

NOTE 1) Refer to *Chapter 3* for details of how to use parameters.

2) For details of how to set parameters, refer to *Section 4.1.6 Operation in Parameter Setting Mode*.

電話： 037-466333

Email: service@repairtw.com

Line id: @zzzz

www.repairtw.com

List of Parameters (Parameter Setting)

Category	Parameter No.	Code	Name	Unit	Lower Limit	Upper Limit	Factory Setting	Remarks
	Cn-00	Not a parameter. (Cn-00 is used to select a special mode for digital operator)						
	Cn-01	Memory switch (See page 564)bit E (encoder selection) *2						
	Cn-02	Memory switch (See page 566) *2(Except bit 6, 7, E)						
Basic Constants	Cn-11	PULSNO	Number of encoder pulses	P/R	513	32768	*1	*2
	Cn-2B	CTLSEL	Control method selection	*1	0	11	0	*2
	Cn-2A	MTRSEL	Motor selection	*1	0	254	*1	*2
Gain Related Constants	Cn-03	VREFGN	Speed reference adjustment gain	(min ⁻¹)/V	10	2000	*1	
	Cn-04	LOOPHZ	Speed loop gain	Hz	1	2000	80	*3
	Cn-05	PITIME	Speed loop integration time constant	0.01 ms	200	51200	2000	*3
	Cn-1A	POSGN	Position loop gain	1/s	1	1000	40	*3
	Cn-1C	BIASLV	Bias	min ⁻¹	0	450	0	
	Cn-1D	FFGN	Feed-forward	%	0	100	0	
	Cn-17	TRQFIL	Torque reference filter time constant	0.1 ms	0	250	*5	
	Cn-28	NFBCC	Speed loop compensation constant	---	0	100	0	
	Cn-0C	TRQMSW	Mode switch torque reference	%	0	800	200	
	Cn-0D	REFMSW	Mode switch speed reference	min ⁻¹	0	10000	0	
	Cn-0E	ACCMSW	Mode switch acceleration	10 min ⁻¹ /s	0	3000	0	
	Cn-0F	ERPMSW	Mode switch error pulse	reference unit	0	10000	0	
Reference related constants	Cn-0A	PGRAT	PG dividing ratio	P/R	16	32768	*1	
	Cn-24	RATB	Electronic gear ratio (numerator)		1	65535	4	*2
	Cn-25	RATA	Electronic gear ratio (denominator)		1	65535	1	*2
	Cn-07	SFSACC	Soft start acceleration time	ms	0	10000	0	*4
	Cn-23	SFSDEC	Soft start deceleration time	ms	0	10000	0	*4
	Cn-26	ACCTME	Position reference acceleration/deceleration constant	0.1 ms	0	640	0	
	Cn-27	FFFILT	Feed-forward filter	0.1 ms	0	640	0	
Torque Related Constants	Cn-08	TLMTF	Forward rotation torque limit	%	0	800	800	
	Cn-09	TLMTR	Reverse rotation torque limit	%	0	800	800	
	Cn-18	CLMIF	Forward external current limit	%	0	800	100	
	Cn-19	CLMIR	Reverse external current limit	%	0	800	100	

Category	Parameter No.	Code	Name	Unit	Lower Limit	Upper Limit	Factory Setting	Remarks
	Cn-06	EMGTRQ	Emergency stop torque	%	0	800	800	
	Cn-13	TCRFGN	Torque reference gain	0.1 V/100%	10	100	30	
	Cn-14	TCRLMT	Speed limit for torque control	min ⁻¹	0	10000	10000	
Sequence Related Constants	Cn-2D	OUTSEL	Output signal selection	*1	110	666	210	
	Cn-0B	TGONLV	Zero-speed level	min ⁻¹	1	10000	20	
	Cn-29	ZCLVL	Zero clamp level	min ⁻¹	0	10000	10	
	Cn-22	VCMLPV	Speed coincidence signal output range	min ⁻¹	0	100	10	
	Cn-1B	COINLV	Positioning completion range	reference unit	0	250	7	
	Cn-1E	OVERLV	Overflow	256 reference unit	1	32767	1024	
	Cn-12	BRKTIM	Time delay from brake reference until servo OFF	10 ms	0	50	0	
	Cn-15	BRKSPD	Speed level for brake reference output during motor operation	min ⁻¹	0	10000	100	
	Cn-16	BRKWAI	Output timing of brake reference during motor operation	10 ms	10	100	50	
Other Constants	Cn-10	JOGSPD	Jog speed	min ⁻¹	0	10000	500	
	Cn-1F	SPEED1	1st speed (contact input speed control)	min ⁻¹	0	10000	100	
	Cn-20	SPEED2	2nd speed (contact input speed control)	min ⁻¹	0	10000	200	
	Cn-21	SPEED3	3rd speed (contact input speed control)	min ⁻¹	0	10000	300	
	Cn-2C	PGPWR	PG power supply voltage change	0.1 mV	52000	58000	52500	

C

Line id: @zzzz

: Parameters must be set and checked before turning the motor power ON.

- Note**
- *1 Refer to page 568.
 - *2 After changing the setting, always turn the power OFF, then ON. This makes the new setting valid.
 - *3 Automatically set by auto tuning function
 - *4 To use soft start function, always set both Cn-07 and Cn-23.
 - *5 6.0kW or less : 4, 7.5kW : 8, 11.0 to 15.0kW : 16

LIST OF USER CONSTANTS

List of Parameters (Memory Switch Setting) (1)

	Parameter No.	Bit No.	Setting		Factory Setting	
Input signal enable/disable	Cn-01	0	0	1	0	
			Uses servo ON input (/S-ON).	Does not use servo ON input (/S-ON). Servo is always ON.		
		1	0	1	0	
			Uses SEN signal input (SEN) when absolute encoder is used.	Does not use SEN signal input (SEN) when absolute encoder is used. SERVOPACK automatically treats signal voltage as high level.		
		2	0	1	0	
			Uses forward rotation prohibited input (P-OT).	Does not use forward rotation prohibited input (P-OT). Forward rotation is always possible.		
3	0	1	0			
	Uses reverse rotation prohibited input (N-OT).	Does not use reverse rotation prohibited input (N-OT). Reverse rotation is always possible.				
Reserved		4	Reserved : Setting = 0 (do not change the setting)		0	
Operation performed at recovery from power loss		5	0	1	0	
			Resets servo alarm status at power recovery from its momentary power loss.	Remains in servo alarm status at power recovery from momentary power loss.		
Sequence selection at alarm condition		6	0	1	0	
			Stops the motor by applying dynamic brake (DB)at base block.	Makes the motor coast to a stop at base block.		
		7	0	1	*1	
			At base block, stops the motor by applying dynamic brake (DB)and then release DB.	At base block, stops the motor by applying dynamic brake (DB)but does not release DB.		
		8	0	1	0	
			Stops the motor according to bit 6 setting when overtravel is detected (P-OT, N-OT).	Decelerates the motor to a stop by applying the torque specified in Cn-06 when overtravel is detected (P-OT, N-OT).		
9	0	1	0			
	When overtravel is detected (P-OT, N-OT), decelerates the motor to a stop by applying the torque specified in Cn-06 and then performs Servo OFF.	When overtravel is detected (P-OT, N-OT), decelerates the motor to a stop by applying the torque specified in Cn-06 and then turns the zero-clamp.				
Process selection for Servo OFF		A	0	1	0	
			Clears error pulse at Servo OFF	Does not clear error pulse at Servo OFF		
Mode switch selection		B	0	1	0	
			Uses mode switch function. Follows Cn-01 bits D, C	Does not use mode switch function.		
		D·C	0·0	0·1	1·0	1·1
		Uses internal torque reference as a condition (Level setting : Cn-0C)	Uses speed reference as a condition (Level setting : Cn-0D)	Uses acceleration as a condition (Level setting : Cn-0E)	Uses error pulse as a condition (Level setting : Cn-0E)	

	Parameter No.	Bit No.	Setting		Factory Setting
Encoder selection	Cn-01	E	0	1	*2
			Uses incremental encoder.	Uses absolute encoder.	
Reserved		F	Reserved : Setting = 0 (do not change the setting)		0

 : Parameters must be set and checked before turning the motor power ON.

*1 less than or equal to 1.5 kW : 1 greater than or equal to 2.0 kW : 0

*2 If Applicable motor is SGMG, SGMS, SGM, SGMP type : 0 SGMD type : 1

NOTE For the Cn-01 memory switch, always turn the power OFF, then ON after changing the setting. This makes the new setting valid.

C

上正科技有限公司
 購買、維修 此手冊零組件
 電話： 037-466333
 Email: service@repairtw.com
 Line id: @zzzz
 www.repairtw.com

List of Parameters (Memory Switch Setting) (2)

	Parameter No.	Bit No.	Setting					Factory Setting
Rotation direction selection	Cn-02	0	0		1			0
			Defines counterclockwise (CCW) rotation as forward rotation.		Defines clockwise (CW) rotation as forward rotation (reverse rotation mode).			
Home position error processing selection		1	0		1			0
			Detects home position error (when absolute encoder is used).		Does not detect home position error.			
Analog speed limit function		2	0		1			0
			Does not use analog speed limit function		Uses analog speed limit function			
Reference pulse form		5·4·3	0·0·0	0·0·1	0·1·0	0·1·1	1·0·0	0·0·0
			Sign + Pulse	CW+CCW	A-phase + B-phase (x1 multiplication)	A-phase + B-phase (x2 multiplication)	A-phase + B-phase (x4 multiplication)	
Analog monitor selection		6	0		1			0
			Outputs torque to TRQ-M		Outputs reference speed to TRQ-M			
		7	0		1			0
			Outputs speed to VTG-M		Outputs position error to VTG-M			
Analog current limit function		8	0		1			0
			Does not use analog current limit function		Uses analog current limit function			
Torque feed-forward function		9	0		1			0
			Does not use torque feed-forward function		Uses torque feed-forward function			
Clear signal		A	0		1			0
			Clears the error counter when an error counter clear signal is at high level		Clears the error counter on the rising edge of an error counter clear signal			
Reserved		B	Reserved : Setting = 0 (do not change the setting)					0
Torque filter		C	0		1			*
			Uses torque filter as primary filter		Uses torque filter as secondary filter			
Reference pulse form		D	0		1			0
			Does not invert reference pulse logic		Inverts reference pulse logic			
Position error monitor		E	0		1			0
			Displays position error in x1 reference units while in monitor mode		Displays position error in x100 reference units while in monitor mode			
Reference pulse filter		F	0		1			0
			Selects filter time constant 'small'. (450 kpps max)		Selects filter time constant 'large'. (200 kpps max)			

* 5.0 kW or less : 0, 6.0kW or more : 1

NOTE For the Cn-02 memory switch, always turn the power OFF, then ON after changing the setting. This makes the new setting valid. However, bits 6, 7, E become valid immediately after setting

***1 Control method selection (Cn-2B) setting values**

Setting values	Control method
0	Speed control (analog reference)
1	Position control (pulse train reference)
2	Torque control (analog reference)
3	Speed control (contact reference) ↔ Speed control (0 reference)
4	Speed control (contact reference) ↔ Speed control (analog reference)
5	Speed control (contact reference) ↔ Position control (pulse train reference)
6	Speed control (contact reference) ↔ Torque control (analog reference)
7	Position control (pulse train reference) ↔ Speed control (analog reference)
8	Position control (pulse train reference) ↔ Torque control (analog reference)
9	Torque control (analog reference) ↔ Speed control (analog reference)
10	Speed control (analog reference) ↔ Zero clamp control
11	Position control (pulse train reference) ↔ Position control (inhibit)

- Outputs signal selection (CN-2D) setting values
Selects which function of signal sent to output signal of 1CN.

1st decimal digit	to select function of CN-25, 26 (/COIN, /V-CMP)
2nd decimal digit	to select function of CN-27, 28 (/TGON)
3rd decimal digit	to select function of CN-29, 30 (/S-RDY)

Setting value	Function
0	/COIN, /V-CMP (only assigned to 1CN-25, 26)
1	/TGON
2	/S-RDY
3	/CLT
4	/BK
5	OL warning
6	OL alarm : 037-466333

Email: service@repairtw.com

Line id: @zzzz

www.repairtw.com

LIST OF USER CONSTANTS

• Factory settings

SERVOPACK models	Applicable motor type	Cn-2A	Cn-11 Cn-0A	Cn-03
SGDB-05ADG	SGMG-05A□A	142	8192	250
SGDB-10ADG	SGMG-09A□A	143		
SGDB-15ADG	SGMG-13A□A	144		
SGDB-20ADG	SGMG-20A□A	145		
SGDB-30ADG	SGMG-30A□A	146		
SGDB-44ADG	SGMG-44A□A	147		
SGDB-60ADG	SGMG-55A□A	148		
SGDB-75ADG	SGMG-75A□A	149		
SGDB-1AADG	SGMG-1AA□A	140		
SGDB-1EADG	SGMG-1EA□A	150		
SGDB-03ADM	SGMG-03A□B	171	8192	167
SGDB-07ADM	SGMG-06A□B	172		
SGDB-10ADM	SGMG-09A□B	173		
SGDB-15ADM	SGMG-12A□B	174		
SGDB-20ADM	SGMG-20A□B	175		
SGDB-30ADM	SGMG-30A□B	176		
SGDB-44ADM	SGMG-44A□B	177		
SGDB-60ADM	SGMG-60A□B	178		
SGDB-10ADS	SGMS-10A□A	163	4096	500
SGDB-15ADS	SGMS-15A□A	164		
SGDB-20ADS	SGMS-20A□A	165		
SGDB-30ADS	SGMS-30A□A	166		
SGDB-44ADS	SGMS-40A□A	167		
SGDB-50ADS	SGMS-50A□A	168	1024	333
SGDB-30ADD	SGMD-22A□A	155		
SGDB-44ADD	SGMD-32A□A	156		
SGDB-50ADD	SGMD-40A□A	157		
SGDB-05AD	SGM-04A	106		
SGDB-10AD	SGM-08A	107	2048	500
SGDB-05ADP	SGMP-04A	126		
SGDB-10ADP	SGMP-08A	127		
SGDB-15ADP	SGMP-15A	128		



Appendix D

List of Alarm Displays

SGDB SERVOPACK allows up to 10 last alarms to be displayed at a digital operator. This function is called a trace-back function.

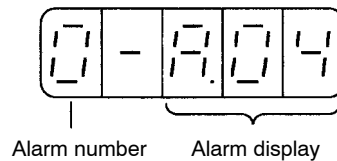

This appendix provides the name and meaning of each alarm display.

For details of how to display an alarm, refer to the following section:
Section 4.2.1 Operation in Alarm Trace-back Mode

For the cause of each alarm and the action to be taken, refer to the following section:

Section 6.2.1 Troubleshooting Problems with Alarm Display

Email: service@repairtw.com

Line id: @zzzz

www.repairtw.com

Alarm Display

Alarm Display on Digital Operator	Alarm Output				Alarm Name	Meaning	Remarks
	Alarm Code Output			ALM Out-put			
	ALO1	ALO2	ALO3				
A.00	OFF	OFF	OFF	OFF	Absolute data error	Absolute data fails to be received, or received absolute data is abnormal.	For absolute encoder only
A.02	OFF	OFF	OFF	OFF	Parameter breakdown	Checksum results of parameters are abnormal.	
A.04	OFF	OFF	OFF	OFF	Parameter setting error	The parameter setting is outside the allowable setting range.	
A.10	ON	OFF	OFF	OFF	Overcurrent	An overcurrent flowed through the power transistor.	
A.30	ON	ON	OFF	OFF	Detection of regenerative error	Regenerative circuit is faulty	
A.31	ON	ON	OFF	OFF	Position error pulse overflow	Position error pulse has exceeded the value set in parameter Cn-1E (overflow).	
A.40	OFF	OFF	ON	OFF	Main circuit voltage error detection	Main circuit voltage is abnormal	
A.51	ON	OFF	ON	OFF	Overspeed	Rotation speed of the motor has exceeded detection level	Detection level = Maximum rotation speed x 1.1 or x1.2
A.71	ON	ON	ON	OFF	Overloaded (high load)	The motor was running for several seconds to several tens of seconds under a torque largely exceeding ratings.	
A.72	ON	ON	ON	OFF	Overloaded (low load)	The motor was running continuously under a torque largely exceeding ratings	
A.80	OFF	OFF	OFF	OFF	Absolute encoder error	The number of pulses per absolute encoder revolution is abnormal.	For absolute encoder only
A.81	OFF	OFF	OFF	OFF	Absolute encoder backup error	All three power supplies for the absolute encoder (+5 V, battery and internal capacitor) have failed.	For 12 bit absolute encoder only
A.82	OFF	OFF	OFF	OFF	Absolute encoder checksum error	The checksum results of absolute encoder memory is abnormal.	For 12 bit absolute encoder only



Checksum

An automatic check function for a set of data such as parameters. It stores the sum of parameter data, recalculates the sum at specific timing, and then checks whether the stored value matches the recalculated value. This function is a simple method of checking whether a set of data is correct.

Alarm Display on Digital Operator	Alarm Output				Alarm Name	Meaning	Remarks
	Alarm Code Output			ALM Output			
	ALO1	ALO2	ALO3				
A.83	OFF	OFF	OFF	OFF	Absolute encoder battery error	Battery voltage for the absolute encoder is abnormal.	For 12 bit absolute encoder only
A.84	OFF	OFF	OFF	OFF	Absolute encoder data error	Received absolute data is abnormal.	For 12 bit absolute encoder only
A.85	OFF	OFF	OFF	OFF	Absolute encoder over-speed	The motor was running at a speed exceeding 400 min^{-1} when the absolute encoder was turned ON.	For 12 bit absolute encoder only

OFF: Output transistor is OFF

ON: Output transistor is ON

D

上正科技有限公司

購買、維修 此手冊零組件

電話： 037-466333

Email: service@repairtw.com

Line id: @zzzz

www.repairtw.com

LIST OF ALARM DISPLAYS

Alarm Display on Digital Operator	Alarm Output				Alarm Name	Meaning	Remarks
	Alarm Code Output			ALM Output			
	ALO1	ALO2	ALO3				
A.A1	ON	ON	ON	OFF	Heat sink overheated	Heat sink of SERVOPACK was overheated	
A.b1	OFF	OFF	OFF	OFF	Reference input read error	SERVOPACK CPU failed to detect reference input.	
A.C1	ON	OFF	ON	OFF	Servo overrun detected	The servomotor (encoder) ran out of control.	
A.C2	ON	OFF	ON	OFF	Encoder output phase error	Phases A, B and C output by the encoder are abnormal.	
A.C3	ON	OFF	ON	OFF	Encoder A-, B-phase disconnection	Wiring in encoder phase A or B is disconnected.	
A.C4	ON	OFF	ON	OFF	Encoder C-phase disconnection	Wiring in encoder phases C is disconnected.	
A.F1	OFF	ON	OFF	OFF	Power lines open phase	One phase is not connected in the main power supply	
A.F3	OFF	ON	OFF	OFF	Power loss error	A power interruption exceeding one cycle occurred in AC power supply.	only when bit 5 of Cn-01 set to 1
CPF00	Undefined				Digital operator transmission error 1	Digital operator fails to communicate with SERVOPACK even five seconds after power is turned ON.	These alarms are not stored in alarm trace-back memory.
CPF01	Undefined				Digital operator transmission error 2	Transmission error has occurred five consecutive times.	
A.99	OFF	OFF	OFF	ON	Not an error	Normal operation status	

D

OFF: Output transistor is OFF

ON: Output transistor is ON

購買、維修 此手冊零組件

電話 037-466333

Email: service@repairtw.com

Line id: @zzzz

www.repairtw.com

INDEX

Numbers

1CN connector
dimensional drawings, 481
specifications, 481

1CN connector kit, 31

A

absolute data
exchange sequence, 156
transmitting sequence, 158

absolute value detection system, 152

alarm, display, list, 570

alarm code output, 127

alarm output signals, wiring, 127

alarm traceback data, clearing, 213

alarm traceback mode, 194

alarms

display, 160

troubleshooting, 503

Servo, resetting using Digital Operator, 180

servo, reset, 180

alignment, 25

radial load, 26

thrust load, 26

analog monitor, 99

autotuning, 204

adjustment of position control Servopacks, 546

adjustment of speed-control Servopacks, 542

precautions, 201

autotuning function, 117

Digital Operators, 201

B

battery, 155

absolute encoder, 480

replacement, absolute encoder, 502

bits, turning ON and OFF, 189

brake power supply, 31

dimensional drawings, 466

internal circuit, 467

specifications, 466

C

cables, 32, 142

encoders

dimensional drawings, 469

specifications, 469

for connecting PC and Servopack, 494

motor

connectors, 462

dimensional drawings, 446

specifications, 446

specifications, 442

tension, 142

comparators, 9

connections

contact input signal terminals, 77

contact output signal terminals, 78

connector kits, 447

dimension drawings, 447

specifications, 447

connector terminal block conversion unit, 31, 483

connectors

1CN, test run, 42

2CN, reverse rotation mode, 55

absolute encoder, 168, 170

Digital Operator, 175

encoder cables, 462

incremental encoder, 167, 169

motor cables, 462

Servomotors with holding brake, 394

IP67-based, 398

Servomotors without holding brake, 392

IP67-based, 396

standard-type motor without brake, 171, 173

standard-type motor with brake, 172, 174

terminal layouts, 166

Servopack, 166

contact input signal terminals, connections, 77

contact input speed control function, 83

motor speeds, 84

prohibiting, 63

soft start time, 84

contact output signal terminals, connections, 78

controlled systems

components, 6

meaning, 5

current detection offset, manual adjustment mode, 217

D

deceleration stop mode, 57

detectors

encoders, 8

meaning, 5

Digital Operator, 31

Digital Operators, 14

- alarm traceback mode, 194
- autotuning, 201
- connection, 178
- dimensional drawings, 412
- mode selection, 181
 - monitor mode, 191
 - status display mode, 182
 - user constant setting mode, 186
- motor operation, 198
- selection, 235
 - flowchart, 236
- servo alarm reset, 180
- simple motor check, 197
- test run, 43

dimensional diagrams, noise filter, 486

dimensional drawings, 292

- 1CN connector, 481
- brake power supply, 466
- cables, encoders, 469
- connector kits, 447
- Digital Operators, 412
- Encoder Signal Converter Unit, 492
- motor cables, 446
- regenerative resistor unit, 490
- Servomotors, 292–326
- Servopacks, 400
- variable resistors, 491

dividing, 73

drive systems, 6

dynamic brake, 106

- stop mode, 58

E

electronic gear function, 79

- setting, 79

electronic gear ratio, 79

- for different load mechanisms, 82
- load travel distance per revolution of load shaft in reference units, 80
- machine specifications, 79
- number of encoder pulses for the SGM Servomotor, 79
- reference unit, 80

encoder output, 73

- signals, divided, 73

encoder pulses, number per revolution, 102

Encoder Signal Converter Unit

- dimensional drawings, 492
- specifications, 492

Encoder Specifications, 20

encoders

- absolute, 8, 152
 - battery, 480
 - battery replacement, 502
 - home position error detection, 161
- cables
 - connectors, 462
 - dimensional drawings, 469
 - specifications, 469
- extending cables, 162
- incremental, 8
- power voltage adjustment, 104
- specification, 76

error counter, clearing, 72

external torque limit, 61

external torque limit input, 62

- forward, 62
- reverse, 62

F

feed-forward control, 119

feedback control, meaning, 3

fuse, 144

G

gain

- adjustment, 114–117
- AC Servopack, 540
- setting references, load inertia ratio, 551

gears, lubrication, 245, 255

ground wire, 142

ground-fault interrupter, 17

grounding, 17

- wiring, 145

H

high-voltage lines, Servopacks, 164

holding brake, 108

- electrical specifications, 200-VAC SGM Servomotors, 239, 250, 260, 267

home position error detection, 161

host controllers, 5, 10, 31

hot start, 288

I

I/O signal terminals, list, 556

impact resistance, 270

INHIBIT function. *See* reference pulse inhibit function

input pulse multiply function, 71

input signal terminals

- alarm reset, 130
- battery, 75
- error counter clear input, 72
- forward external torque limit input, 62
- forward rotation prohibited, 56
- I/O power supply, 77
- motor rotation direction, 86
- proportional/integral control, 67
- reference pulse input, 70
- reference sign input, 70
- reverse external torque limit input, 62
- reverse rotation prohibited, 56
- SEN signal input, 75
- servo ON, 130
- signal ground for speed reference input, 64, 91
- signal ground for torque reference input, 90
- speed reference input, 64, 91
- speed selection, 85
- torque reference input, 90
- zero-clamp speed control, 107

inspection, 500, 501

- Servomotors, 500
- Servopacks, 501

installation, 18

- servomotor, alignment, 25
- Servomotors, 24
- Servopacks, 27

internal torque limit, 59

J

jog speed, 101

L

limit switch, 56

- overtravel limit function, 56

load inertia, 290

- gain settings, 551

loads

- allowable radial load, 269
- allowable thrust load, 269

M

machine data table, 231

machine rigidity, 203

- selection, 201

magnetic contactor, 31

maintenance, 500, 501

- Servomotors, 500
- Servopacks, 501

MCCB, 31, 143, 144, 486

mechanical tolerance, 270

memory switches. *See* user constants

mode selection, Digital Operators, 181

mode switch, 121

- detection points
- error pulse, 124
- motor acceleration, 123
- speed reference, 123
- torque reference, 122

molded-case circuit breaker. *See* MCCB

monitor mode, 191

motor

- checking, Digital Operators, 197
- operation, Digital Operators, 198

N

N-OT input signal, 56

noise control, 17

- filter, 31, 143, 150
- dimensional diagrams, 486
- installation, 146
- specifications, 486
- wiring, 144

order lists, 424

output phase, form, 75

- absolute encoder, 75
- incremental encoder, 75

output signal terminals

- alarm code output, 128
- brake interlock output, 110
- encoder output, 74, 75
- frame ground, 75
- output signal ground common, 78
- overload alarm, 138
- overload warning, 138
- positioning complete output, 132
- running output, 136
- servo alarm output, 127
- servo ready, 140
- signal ground, 75
- signal ground for alarm code output, 128
- signal ground for servo alarm output, 127
- speed coincidence output, 134
- speed monitor, 99
- torque limit output, 60
- torque monitor, 99

上正科技有限公司
購買、維修 此手冊零組件

電話： 037-46630

Email: service@repairtw.com

Line id: @zzz

www.repairtw.com

overhanging load
 precautions, 17
 Servomotors, 291

overload
 alarm, 138
 characteristics, Servopacks, 288
 warning, 138

overtravel limit function, 56
 limit switch, 56

P

P-OT input signal, 56

peripheral devices
 selection, 414
 flowchart, 415
 specifications, 442
 wiring, 30

personal computer, 31

position references, inputs, 68
 line driver output, 69
 open collector output, 69

positioning complete signal, 131

positioning time, minimizing, 117

power amplifiers, 9

power loss, 141

precautions, 16

pressure control, 88

proportional control, 120

proportional/integral control, 9, 119
 signal, 67

protective sequence, 127

pulse dividing ratio, 76

R

radial load, 26

ratings
 100-VAC SGM Servomotors, 265, 267
 200-VAC SGM Servomotors, 237
 SGDM Servopacks, 285

reference offset, 207
 automatic adjustment, 105, 115, 207
 manual adjustment, 105, 115

reference pulse
 form, 70
 input
 allowable voltage level, 72
 timing, 72

reference pulse inhibit function, 97

reference pulse input filter selection function, 98

regenerative resistor unit, 31
 dimensional drawings, 490
 specifications, 490

regenerative unit
 connection, 151
 models, 151

residual voltage, precautions, 16

reverse rotation mode, 54, 55
 2CN connector, 55
 user constant, 55

rotation, 57
 forward, prohibiting, 57
 reverse, prohibiting, 57

running output signal, 136

S

SEN signal, 153

servo amplifiers, 9
 meaning, 5

servo drive, meaning, 4

servo mechanisms
 illustration, 5
 meaning, 2

servo OFF, 58

servo ON input signal, 130

Servomotors, 500
 100-VAC SGM ratings, 265, 267
 100-VAC SGM specifications, 265, 267
 200-VAC SGM ratings, 237
 200-VAC SGM specifications, 237
 200-VAC SGM torque-motor speed characteristics, 240, 251,
 261, 266, 268

AC, 7
 induction, 7
 synchronous, 7
 components, 7
 DC, 7
 dimensional drawings, 292–326
 inspection, 500
 installation, 24
 maintenance, 500
 meaning, 4, 5
 overhanging load, 291
 selection, 223
 flowchart, 225, 229
 machine data table, 231
 setting the type, 103
 test run, 42

Servopacks, 501
 AC, gain adjustment, 540
 dimensional drawings, 400
 high-voltage lines, 164
 inspection, 501

上正科技有限公司
 購買、維修零件及零組件
 電話：03-7466389
 Email: service@up.com.tw
 Line id: @AC7
 www.repair.com.tw

- installation, 27
 - instrument connection examples, 531
 - internal connection diagram, 531
 - maintenance, 501
 - meaning, 4
 - overload characteristics, 288
 - position control
 - autotuning, 546
 - manual adjustment, 547
 - ratings, 285
 - selection, 233
 - according to the motor, 234
 - specifications, 285
 - speed-control
 - autotuning, 542
 - manual adjustment, 543
 - test run, 44
 - servos
 - alarm output, 127
 - alarm reset, 180
 - control systems, meaning, 4
 - gain adjustment, 114, 117
 - meaning, 3
 - SGMGH Servomotors, gear lubrication, 245, 255
 - shaft opening, 25
 - smoothing function, 114
 - position reference acceleration/deceleration time constant, 114
 - soft start function, 86, 113
 - specifications
 - 100-VAC SGM Servomotors, 265, 267
 - 1CN connector, 481
 - 200-VAC SGM Servomotors, 237
 - brake power supply, 466
 - cables, 442
 - encoders, 469
 - connector kits, 447
 - home position pulse, 159
 - incremental pulse, 159
 - noise filter, 486
 - peripheral devices, 442
 - regenerative resistor unit, 490
 - serial data, 158
 - Servopack/Servomotor combination, 282
 - SGDM Servopacks, 285
 - speed bias, 120
 - speed coincidence output signal, 134
 - speed control, 65
 - analog reference, 66
 - contact reference, 66
 - position/torque control, 66
 - zero-clamp, 66
 - speed reference offset, manual adjustment mode, 210
 - speed references, 64
 - gain, 67
 - inputs, 64
 - starting time, 289
 - status display mode, 182
 - stop mode, setting, 105
 - stop torque, 58
 - stopping time, 289
 - surge suppressor, 490
- ## T
- tension control, 88
 - terminals
 - standard-type motor without brake, 171, 173
 - standard-type motor with brake, 172, 174
 - test run, 40
 - minimum user constants, 49
 - motor alone, 42
 - motor connected to the machine, 46
 - position control from the host controller, 48
 - servomotor with brake, 47
 - thrust load, 26
 - torque control, 59, 87
 - torque feed-forward function, 94
 - torque limit
 - input signals, 63
 - output signal, 60
 - value, 96
 - torque reference filter time constant, 115
 - torque restriction function, 61
 - by analog voltage reference, 95
 - torque limit value, 61
 - troubleshooting
 - alarm display, 503
 - without alarm display, 529
- ## U
- user constant setting mode, 186
 - user constants, 55, 56, 63
 - bias, 120
 - brake signal output timing during motor operation, 112
 - brake signal speed level output during motor operation, 112
 - contact input speed control function, 63
 - control mode selection, 63, 65, 83
 - dividing ratio setting, 76, 159
 - dividing ratio settings, 74
 - electronic gear ratio, 81
 - emergency stop torque, 58
 - encoder power voltage adjustment, 104
 - encoder type selection, 76, 102, 154
 - error counter clear signal selection, 73
 - feed-forward gain, 119
 - forward external torque limit, 61
 - forward rotation torque limit, 59
 - jog speed, 101
 - list, 562

mode switch ON/OFF, 124
mode switch selection, 125
motor selection, 103
motor speeds, 84
N-OT input signal, 56
number of encoder pulses, 102, 154
operation at recovery from power loss, 141
operation when motor stops after overtravel, 57
operation when motor stops after servo OFF, 58
output signal selection, 60, 110, 132, 138, 140
overflow, 118
PI/P changeover, 120
position loop gain, 118
positioning complete range, 133, 134, 136
P-OT input signal, 56
reference pulse form selection, 70
reference pulse inhibit function, 97
reference pulse input filter selection function, 98
reverse external torque limit, 61
reverse rotation mode, 55
reverse rotation torque limit, 59
rotation direction selection, 55
SEN input signal, 153
servo ON input signal, 131
soft start time, 84, 113
speed coincidence signal output width, 135
speed limit for torque control I, 92
speed loop gain, 118
speed loop integration time constant, 118
speed reference gain, 67, 93
stopping motor at servo OFF, 58, 106
stopping the motor at overtravel, 57
time delay from brake signal output to servo OFF, 111
torque control, 88
torque feed-forward function selection, 94

torque reference filter selection, 116
torque reference filter time constant, 115
torque reference gain, 92, 95, 96
torque restriction by analog voltage reference, 95
zero-clamp speed control, 107
zero-speed level, 137
zero-clamp level, 108

V

variable resistor, dimensional drawings, 491
vibration class, 271
vibration resistance, 271
voltage resistance test, 17

W

wiring, 30, 34, 55, 142
grounding, 145
main circuit, 34
more than one servo drive, 149
noise control, 144
peripheral devices, 30
precautions, 16, 142
shorting, 2CN connector, 55

Z

zero-clamp function, 67, 107

上正科技有限公司

購買、維修 此手冊零件

電話： 037-466333

Email: service@repairtw.com

Line id: @zzzz

www.repairtw.com

Revision History

The revision dates and numbers of the revised manuals are given on the bottom of the back cover.

MANUAL NO. TSE-S800-16B

Published in Japan September 1996 95-9 ◊

└─ Date of publication

└─ Date of original publication

└─ Revision number

Date of Publication	Rev. No.	Section	Revised Content
September 1995	-		First edition
September 1995	◊1	All Chapters	Slightly revised
May 1996	◊2	All Chapters	Slightly revised
August 1996	◊3	Back cover	Revision: Address
September 1996	◊4		Based on Japanese user's manual, SI-S800-16B<2> printed in September 1996.
May 1997	◊5		Based on Japanese user's manual, SI-S800-16C<3> printed in April 1997.
June 1997	◊6	Back cover	Revision: Address
September 1997	◊7	All Chapters	Addition: Servomotor model SGMG, 15 kW
March 1998	◊8	All Chapters	Slightly revised
April 1998	◊9	All Chapters	Slightly revised
October 1998	◊10	All Chapters	Slightly revised
January 1999	◊11	All Chapters	Slightly revised
October 1999	◊12	All Chapters	Slightly revised
February 2000	◊13	All Chapters	Slightly revised
February 2001	◊14		Based on Japanese user's manual, SI-S800-16F<8> printed in January 2000.
May 2001	◊15	All Chapters	Slightly revised
October 2002	◊16	All Chapters	Slightly revised
September 2003	◊17	All Chapters	Slightly revised
February 2006	◊18	Chapter 3	Slightly revised
August 2007	◊19	Preface	Addition: Caution on fumigation
		5.2.2	Addition: Vibration resistance
April 2008	◊20	Back cover	Revision: Address

Σ Series SGM□/SGDB USER'S MANUAL

IRUMA BUSINESS CENTER (SOLUTION CENTER)

480, Kamifujisawa, Iruma, Saitama 358-8555, Japan
Phone 81-4-2962-5696 Fax 81-4-2962-6138

YASKAWA ELECTRIC AMERICA, INC.

2121 Norman Drive South, Waukegan, IL 60085, U.S.A.
Phone 1-847-887-7000 Fax 1-847-887-7370

YASKAWA ELÉTRICO DO BRASIL LTDA.

Avenida Fagundes Filho, 620 São Paulo-SP CEP 04304-000, Brazil
Phone 55-11-3585-1100 Fax 55-11-5581-8795

YASKAWA ELECTRIC EUROPE GmbH

Am Kronberger Hang 2, 65824 Schwalbach, Germany
Phone 49-6196-569-300 Fax 49-6196-569-312

YASKAWA ELECTRIC UK LTD.

1 Hunt Hill Orchardton Woods Cumbernauld, G68 9LF, United Kingdom
Phone 44-1236-735000 Fax 44-1236-458182

YASKAWA ELECTRIC KOREA CORPORATION

7F, Doore Bldg. 24, Yeoido-dong, Youngdungpo-Ku, Seoul 150-877, Korea
Phone 82-2-784-7844 Fax 82-2-784-8495

YASKAWA ELECTRIC (SINGAPORE) PTE. LTD.

151 Lorong Chuan, #04-01, New Tech Park 556741, Singapore
Phone 65-6282-3003 Fax 65-6289-3003

YASKAWA ELECTRIC (SHANGHAI) CO., LTD.

No.18 Xizang Zhong Road, Room 1702-1707, Harbour Ring Plaza Shanghai 200001, China
Phone 86-21-5385-2200 Fax 86-21-5385-3299

YASKAWA ELECTRIC (SHANGHAI) CO., LTD. BEIJING OFFICE

Room 1011A, Tower W3 Oriental Plaza, No.1 East Chang An Ave.,
Dong Cheng District, Beijing 100738, China
Phone 86-10-8518-4086 Fax 86-10-8518-4082

YASKAWA ELECTRIC TAIWAN CORPORATION

9F, 16, Nanking E. Rd., Sec. 3, Taipei, Taiwan
Phone 886-2-2502-5003 Fax 886-2-2505-1280

電話：037-466333

Email: service@repairtw.com

Line id: @zzzz

www.repairtw.com



YASKAWA

YASKAWA ELECTRIC CORPORATION

In the event that the end user of this product is to be the military and said product is to be employed in any weapons systems or the manufacture thereof, the export will fall under the relevant regulations as stipulated in the Foreign Exchange and Foreign Trade Regulations. Therefore, be sure to follow all procedures and submit all relevant documentation according to any and all rules, regulations and laws that may apply.

Specifications are subject to change without notice for ongoing product modifications and improvements.

© 1995-2008 YASKAWA ELECTRIC CORPORATION. All rights reserved.

MANUAL NO. TSE-S800-16E

Published in Japan April 2008 95-9 -0
07-11-9